

Los Angeles County Metropolitan Transportation Authority



Gold Line I-210 Barrier Replacement Project

March 28, 2019 Board Presentation



Gold Line I-210 Barrier Replacement - Project Limits



Split into 2 Projects for Expediency

Total Project: Marengo Tunnel to Iconic Bridge

Project 1: Michillinda Avenue to Iconic Bridge

Project 2: Marengo Tunnel to Michillinda Ave.

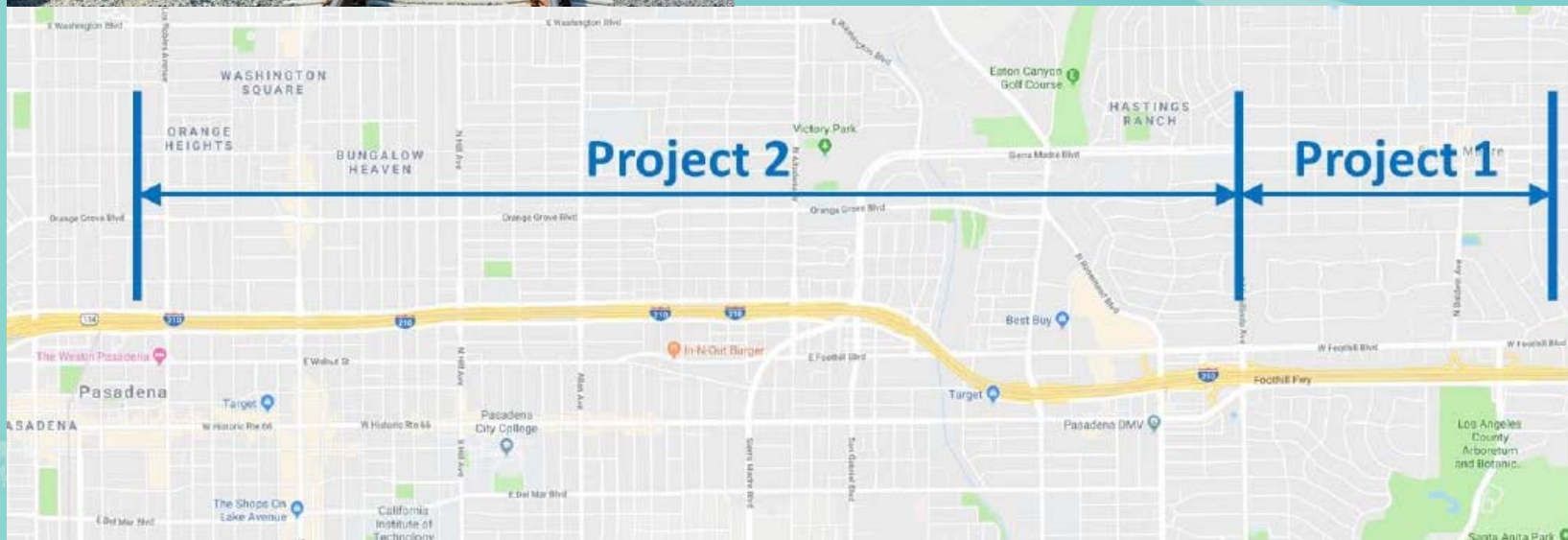

Gold Line I-210 Barrier Replacement - A Safety Project



Metro Gold Line: I-210 Median Vehicle Breach Incident Map:

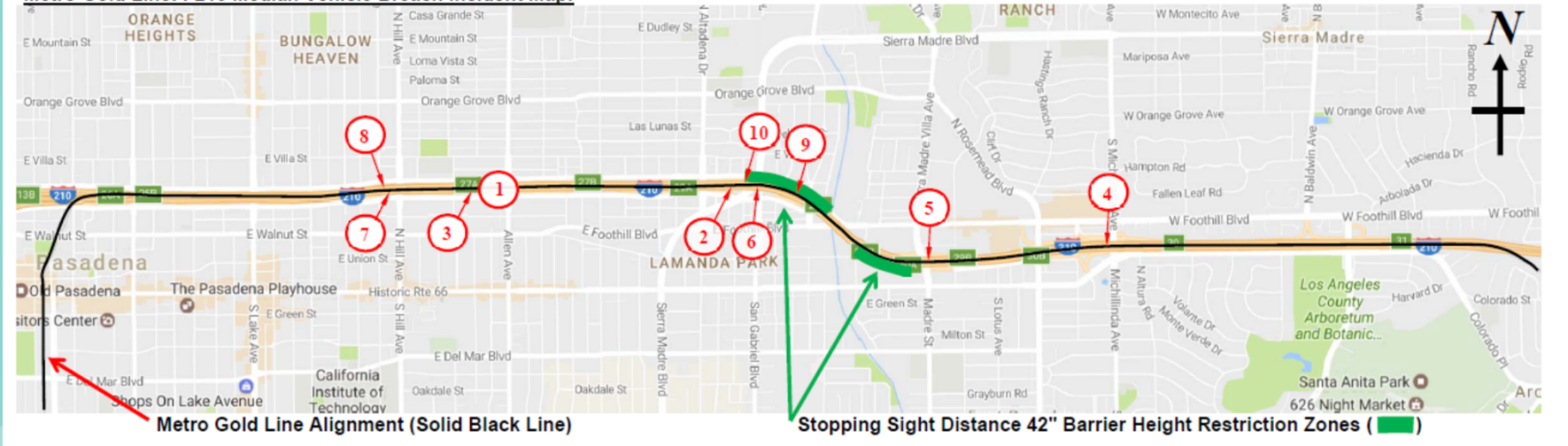

Gold Line I-210 barriers are being replaced to prevent this from occurring in the future.



Gold Line I-210 Barrier Replacement – Existing and Proposed Barrier Configurations

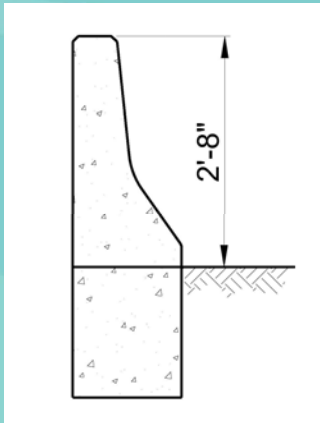

On Ground

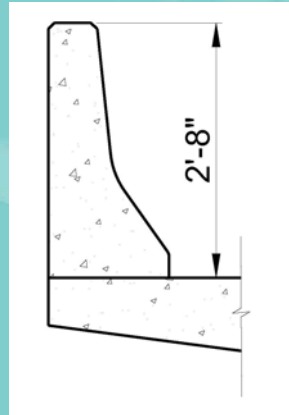

On Bridge

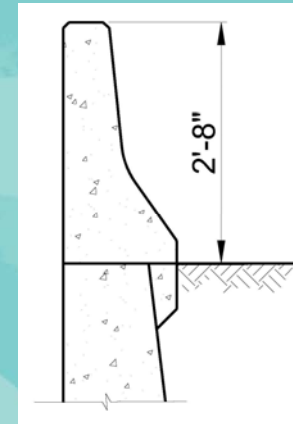

On Retaining Wall

Existing Barrier Configurations

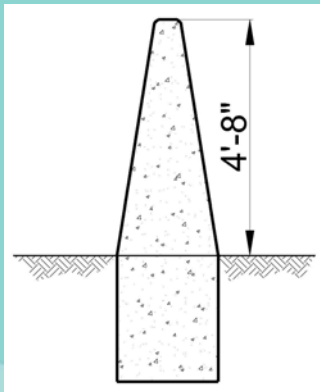

On Ground

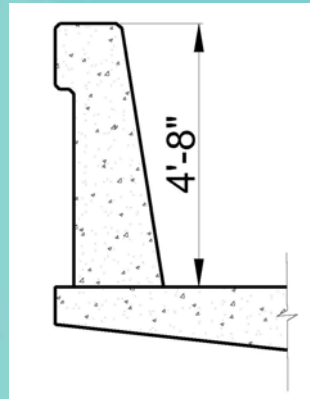

On Bridge

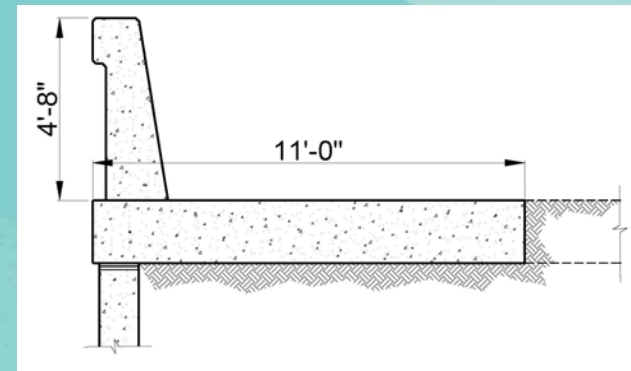

On Retaining Wall



Metro

Proposed Barrier Configurations

Gold Line I-210 Barrier Replacement – Addressing the Challenges

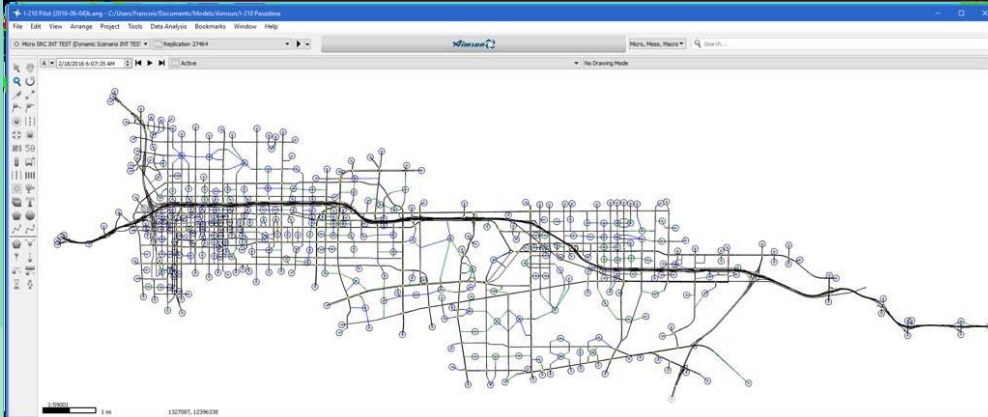

Optimized Solutions:

- Extremely tight workspace causing HOV lane closure and single tracking for the construction of Project 2; complicating environmental clearance
- Complex traffic study underway to quantify traffic impacts to the freeway and city streets



Thank you

