



## AGENDA REPORT

**Meeting Date:** May 7, 2024  
**Item Number:** G-1  
**To:** Honorable Mayor & City Council  
**From:** Daren Grilley, Assistant Director of Public Works/City Engineer  
Samer Elayyan, Engineering Services Manager  
Christine Chung, Project Manager  
**Subject:** METRO PURPLE (D) LINE EXTENSION NORTH PORTAL PROJECT  
**Attachments:**

1. Settlement Agreement
2. North Portal Project Cost Estimates
3. City and Metro Project Cost Summary

---

### **RECOMMENDATION**

Staff recommends City Council discontinue the North Portal Project, meet and confer with the Los Angeles County Metropolitan Transportation Authority (Metro) as required in the Settlement Agreement between the City and Metro, and return to City Council for further consideration if Metro decides to pursue the project and fund the project budget overage.

### **INTRODUCTION**

On May 10, 2022, City Council approved an agreement with HDR Engineering, Inc. (HDR) for the design of a second entrance/exit to the Wilshire/Rodeo Metro Purple Line Station on the north side of Wilshire Boulevard (North Portal). The design started in June 2022, and in early 2023, HDR submitted a preliminary design report that included the basis of design and a preliminary construction cost estimate. The cost estimate is significantly higher than the conceptual estimate that was incorporated into the cost sharing agreement with Metro.

### **DISCUSSION**

On November 10, 2020, City Council entered into a settlement agreement with Metro and agreed that (1) Metro and/or the City will construct a station portal on the north side of Wilshire Boulevard, also known as the "North Portal," at a location approved by City

Meeting Date: May 7, 2024

Council, and (2) Metro will contribute 50% of the total cost of designing and constructing the portal. The agreed upon North Portal project cost (includes design, construction, and construction support and management services) is \$78,500,000, with each party sharing in half of the cost at \$39,250,000. Additionally, City Council certified that the Final North Portal EIR had been completed in compliance with the California Environmental Quality Act, adopted the Findings of Fact and Statement of Overriding Considerations and selected Beverly Drive as the location of the North Portal.

Subsequently, City staff released a request for proposals (RFP) for design of the North Portal in September 2021, and selected HDR based on the firm's qualifications, and the design agreement was approved at the May 10, 2022, City Council Formal Session. HDR started the design in June 2022 and performed a site survey that included the basement of adjacent buildings and submitted the preliminary design (15% design) report. In late January 2023, City and Metro staff reviewed the report and held a workshop with HDR in early February 2023 to discuss the design approach and the cost estimate. City staff requested more information from HDR regarding the cost estimate, and the additional information was submitted to staff early March 2023.

The design report summarized the design approach, constraints, and assumptions that would be considered during the design and construction. The report also provided a preliminary cost estimate that conforms to the requirement of the Association for the Advancement of Cost Engineering (AACE) Class 4 estimate, which is expected to be accurate within a range of -30% to +50%. This class and range are usually used for a design that has been developed less than 15%, where there are still unknown constraints and risks.

The table below summarizes the cumulative estimated project cost:

Scope of Work	Preliminary Cost Estimate
Construction	\$110.2M (including 40% contingency)
Design	\$9.0M
Design Support During Construction	\$5.0M
Construction Management	\$8.8M
Other Support Costs	\$1.2M
<b>Total Estimated Project Cost</b>	<b>\$134.2M*</b>

\* The estimated project cost could range from \$94M to \$201M based on AACE Class 4 range of -30% to +50%.

The total estimated project cost (\$134.2M) based on the 15% preliminary design report is significantly higher than the initial conceptual cost estimate (\$78.5M) that was agreed upon in the settlement agreement. The initial conceptual cost estimate at the time of the settlement agreement was based on the project concept, prior to initiating the actual design. Conceptual level cost estimates (or Class 5 estimates, per AACE) have an expected accuracy range of -50% to +100% (i.e., \$39.3M to \$157M). Therefore, the current cost estimate is near the high end of that range (+70%).

Several factors have contributed to the increase in construction costs over the past four years, including a surge in demand for construction materials, increased prices due to more construction projects worldwide, ongoing supply chain challenges from the global pandemic, and rising labor and transportation costs. The cost of labor has also increased due to the demand for skilled construction workers, particularly in high-growth

Meeting Date: May 7, 2024

regions, and the increases continue to show in the recent bids for various City Capital Improvement Projects.

Depending on Metro's position on the increased construction cost estimate, the City's costs towards the North Portal project could range from \$67.1M (50% of the current estimated project cost) to \$94.95M (if Metro opts to contribute only the originally agreed-upon \$39.25M). On March 27, 2023, City staff met with the Metro Ad-Hoc Committee (previously Mayor Friedman and former Councilmember Bosse) to discuss the North Portal design status and anticipated higher costs. The former Metro Ad-Hoc Committee directed staff to inform stakeholders about the project status and present the matter for City Council discussion at a future City Council meeting.

### **Community Engagement**

City staff initiated community outreach regarding the North Portal project status in May and June 2023. Community outreach included:

- Individual virtual meetings with stakeholders located along Wilshire Boulevard between El Camino Drive and Crescent Drive were held between May 24th and June 1st, 2023. Some of the stakeholders include the Beverly Wilshire Hotel, 9465 Wilshire (Chase Building), Maybourne Beverly Hills, 9401 Wilshire, Spago, AKA, Sixty Hotel, and East West Bank. In addition, staff met with EIR commented stakeholders (property owners, former Technology Committee Advisory), Beverly Hills Conference & Visitors Bureau (CVB), Beverly Hills Chamber of Commerce, and Rodeo Drive Committee (RDC) representatives.
- Staff informed the Southwest Beverly Hills Homeowners Association on May 31, 2023.
- Staff presented regarding the project status at following public meetings throughout June 2023.
  - Metro's monthly community meeting on June 7, 2023
  - Rodeo Drive Committee monthly meeting on June 7, 2023
  - Beverly Hills Chamber of Commerce monthly key stakeholder meeting on June 14, 2023
  - Small Business Task Force Committee Liaison meeting on June 21, 2023
  - Property Owners Task Force Committee Liaison meeting on June 22, 2023
- In addition, Staff notified the stakeholders that they previously met with in 2023 about the City Council meeting scheduled on May 7, 2024.

During the 2023 meetings, the majority of stakeholders expressed concerns about the City potentially funding excessive project costs for a half-portal construction, given that there will be a full portal located nearby at the station on Wilshire Boulevard and Reeves Avenue. There were also suggestions to consider alternative, affordable means to improve mobility across Wilshire Boulevard from the main station entrance.

Based on the feedback received from the community and business committees and the significantly higher project cost estimate, staff recommends discontinuing the North Portal Project and meet and confer with Metro per the Settlement Agreement terms. Upon a decision by the Metro Board, staff would return to City Council for further direction in the event that Metro decides to pursue the project and fund the project budget overage. It is unlikely that Metro will contribute additional funds toward the North

Meeting Date: May 7, 2024

Portal project due to cost overruns in the Purple (D Line) Subway Extension – Section 2 project, as discussed at the LA Metro board meeting in July 2023.

### **FISCAL IMPACT**

Per the settlement agreement, each party pays 50% of the North Portal total project cost (\$78.5 million). If costs exceed \$78.5 million, the parties shall meet and confer in good faith to develop strategies to either reduce costs or increase contributions. The table below outlines multiple scenarios regarding the contribution of both parties toward the project based on the total cost of \$134.2 million.

Contribution Party	Contribution per Settlement Agreement	Contribution if both parties agree to share added costs	Contributions if only City pursues	If neither party agrees to pursue
Beverly Hills	\$39.25 million	\$67.10 million	\$94.95 million	50% of project cost incurred to-date \$5,185,000*
Metro	\$39.25 million	\$67.10 million	\$39.25 million	50% of project cost incurred to date \$5,185,000*
Total	\$78.50 million	\$134.20 million	\$134.20 million	Add total incurred to date \$10,370,000*

\* This cost is approximate and will be verified with Metro

If City and Metro agree not to pursue the North Portal Project, both parties must evenly share the cost incurred to date per the settlement agreement. The total cost incurred to date by both parties is approximately \$10,370,000 (Attachment 3) and the City would pay Metro approximately \$2,554,000 (the difference between the 50% cost and what the City has expended so far on the EIR and design). Funding for a portion of the City's share is included in the Capital Improvement Project (CIP) No. 00725: Metro Rodeo Station North Portal.

Shana Epstein,  
Director of Public Works

---

Approved By

# **Attachment 1**

## SETTLEMENT AGREEMENT

This Settlement Agreement ("**Agreement**") is dated as of November 10, 2020, and is entered into by and between the Los Angeles County Metropolitan Transportation Authority ("**Metro**") and the City of Beverly Hills (the "**City**"). Metro and the City are individually referred to herein as a "Party" and collectively as the "Parties."

### RECITALS

A. Metro and the Federal Transit Administration ("**FTA**") prepared a joint Environmental Impact Statement ("**EIS**")/Environmental Impact Report ("**EIR**") for the Westside Subway Extension, Section 2 ("**Project**") pursuant to the National Environmental Policy Act ("**NEPA**") (42 U.S.C. § 4321 *et seq.*) and the California Environmental Quality Act ("**CEQA**") (Cal. Pub. Resources Code, § 21000 *et seq.*).

B. On November 27, 2017, following a federal court ruling in a legal challenge of the EIS/EIR by the City and the Beverly Hills Unified School District, FTA released a Final Supplemental EIS ("**FSEIS**") and Supplemental Record of Decision ("**ROD**") for the Project. Metro was not a party to the federal actions challenging the EIS/EIR, which are no longer pending in federal court.

C. The Project is a heavy rail transit subway that will extend the existing Metro Purple Line subway from Wilshire/La Cienega to Century City. The Project's alignment is roughly 2.7 miles in length and will be entirely underground, mostly beneath Wilshire Boulevard. Two new stations will be constructed at approximately one-mile intervals, serving major activity and employment centers in Beverly Hills and Century City. The Project's Wilshire/Rodeo Station ("**Station**"), located under and adjacent to Wilshire Boulevard and generally bounded by Beverly Drive on the west and S. Canon Drive on the east, is the only station located within the City. Metro's Design-Build Contractor for the Project is Tutor Perini/O&G ("**Project Contractor**").

D. FTA, Metro, and the City are currently involved in one lawsuit pending before the Federal District Court in Los Angeles County: *City of Beverly Hills v. Federal Transit Administration, et al.*, Case No. CV-18-03891 GW (SSx) ("**Federal Action**"). In the Federal Action the City alleges that the FSEIS inadequately addresses the federal court ruling.

E. Despite the Federal Action, Metro and the City are otherwise cooperating to ensure timely completion of the Project. To that end, on February 19, 2019, Metro and the City entered into that certain Memorandum of Agreement for Contract C1120 of the Purple Line Extension Project – Section 2 between the City of Beverly Hills and the Los Angeles County Metropolitan Transportation Authority, City Agreement No. 71-19 ("**MOA**"), which sets forth the respective rights and responsibilities of the Parties in order to facilitate Project construction in a manner that protects City businesses and residents.

F. The City Council approved the MOA based in part on the Parties' commitment in the MOA to bargain in good faith regarding representations provided by Metro's Chief Executive Officer to jointly fund with the City the construction of a second Station portal on the north side of Wilshire Boulevard at a location approved by the City Council ("**North Portal**"), with Metro

contributing fifty (50) percent of the total cost of designing and constructing the North Portal; and (2) Metro would cause to be constructed and then make available public restrooms to serve Station customers.

G. By this Agreement, Metro desires to satisfy the representations it made to the City Council. To that end, this Agreement sets forth the respective rights, responsibilities, and funding obligations for the joint development of a supplemental Station portal and restrooms to serve the Wilshire/Rodeo Station, as well as funding for emergency rescue equipment for the City's Fire Department to use in the event of a tunnel emergency. In exchange, the City desires to dismiss the Federal Action and to forgo all potential legal challenges to the FSEIS and ROD.

H. On the terms set forth herein, the Parties desire to fully settle and resolve their respective rights, liabilities, obligations and all controversies arising from and related to the State Action and Federal Action as against each other.

**NOW, THEREFORE**, in consideration of the foregoing and the mutual covenants set forth below, and further good and valuable consideration, the receipt and sufficiency of which is hereby acknowledged, the Parties do hereby agree, as follows:

1. **Dismissal of Litigation.** The Federal Action shall be dismissed in accordance with the following procedure:

1.1 Within five (5) business days of the Effective Date, the City shall file with the Federal District Court a Request for Dismissal with Prejudice of the Federal Action. Within five (5) business days of receiving a conformed copy of the request for dismissal form showing that the Court Clerk has entered the dismissal, the City shall provide Metro's counsel with a copy of same.

1.2 The City covenants and agrees that it shall not object to, challenge, or be a party to any litigation related to FTA's or Metro's compliance with the requirements of NEPA or CEQA for the Project; provided, however, that nothing in this Agreement shall be construed as limiting, and the City expressly reserves all rights it has to object to, challenge and be a party to any litigation brought against or involving FTA or Metro related to compliance with any mitigation measure adopted pursuant to NEPA or CEQA, any other subject, or to bring a CEQA and/or NEPA challenge to any material change in the Project. Nothing herein shall prohibit or preclude the rights of the City to provide comments on any action taken by the FTA and Metro in connection with any supplemental analysis, or the lack thereof, undertaken by them in furtherance of the Project.

2. **North Portal Development.** The City desires to design and construct a supplemental portal for ingress and egress to the Station on the north side of Wilshire Boulevard, known as the North Portal. At least three alternate, conceptual designs and locations will be analyzed as part of the environmental review process described below. The City Council may approve the final location and design of the North Portal at the conclusion of the environmental review process, or may decline to proceed with construction and development of the North Portal. At a minimum, the North Portal is expected to contain ticket fare gates, stairs, an escalator, elevators, and Fire/Life/Safety improvements. This Agreement sets forth the roles and responsibilities among and between the City and Metro with respect to the North Portal.

2.1 Responsibilities of the City. The following responsibilities are assigned to the City with respect to the North Portal:

2.1.1. Procure one or more environmental consultants, in accordance with applicable contracting laws and regulations, for the preparation of the North Portal's environmental document pursuant to CEQA, including subcontracts for any associated technical studies. To the greatest extent possible, the environmental document will be prepared in a manner that complies with the substantive provisions of NEPA so as to accommodate Metro's procurement role pursuant to Section 2.2.1 if the need arises.

2.1.2. Pursuant to CEQA Guidelines Section 15051(d), serve as the lead agency under CEQA. The City will complete the procedural tasks CEQA assigns to the lead agency, such as filing the notice of completion, submitting documents to the State Clearinghouse and responsible agencies, and serving as the recipient of all comments on the environmental document.

2.1.3. Upon completion of the CEQA process, determine whether or not to authorize construction of the North Portal, and, if so, determine the final location and design of the North Portal substantially based on those locations and designs reviewed in the environmental document.

2.1.4. Upon completion of the CEQA process, procure one or more design contractors for the North Portal (respectively, "**North Portal Design Contractor**") in accordance with applicable contracting laws and regulations, unless the FTA authorizes Metro to issue a change order to the Project Contractor for the design of the North Portal. If the FTA authorizes such a change order, and the Parties mutually agree to the Project Contractor performing the North Portal's design pursuant to a contract change, then Metro shall assume such procurement responsibilities pursuant to Section 2.2.1 below.

2.1.5 Within one hundred and twenty (120) days of the North Portal Design Contractor or the Project Contractor completing a final design for the North Portal, the City shall proceed to solicit bids from qualifying contractors to serve as the "**North Portal Construction Contractor**" in accordance with applicable contracting laws and regulations, unless the FTA authorizes Metro to issue a change order to the Project Contractor for the construction of the North Portal. The lowest, responsible bid received by the City or the final change order price received by Metro, plus a ten percent (10%) contingency, is hereafter referred to as the "**Construction Price.**"

2.1.5. If the Council agrees to proceed with the North Portal, Complete the North Portal in accordance with this Agreement, design and construction contracts, and all other applicable federal, state, and local laws and regulations.

2.1.6. If the Council agrees to proceed with the North Portal, Complete the North Portal in accordance with the MOA, the terms of which shall be incorporated into this Agreement as if set forth in full.

2.2 Responsibilities of Metro. The following responsibilities are assigned to Metro with respect to the North Portal:



2.2.1. If the FTA authorizes Metro to issue a change order to the Project Contractor, and the Parties mutually agree to the Project Contractor performing the North Portal's design and construction pursuant to a change order, then issue the change order for the design and construction of the North Portal to the Project Contractor after the Parties have complied with CEQA and NEPA.

2.2.2. Serve as a responsible agency under CEQA and complete the procedural tasks CEQA assigns to responsible agencies.

2.2.3. If Metro issues the change order pursuant to Section 2.2.1, then comply with any remaining substantive requirements necessary for the environmental document to comply with NEPA and coordinate with the FTA to complete all procedural tasks NEPA assigns to a lead agency and project sponsor, respectively.

2.2.4. Assist the City with construction management, including oversight of the design and construction contractors, preparation and monitoring of construction schedules and milestones, and ensure that all standards and requirements of this Agreement, design and construction contracts, and applicable City and Metro standards are met.

2.2.5. If Metro issues the change order pursuant to Section 2.2.1, complete the North Portal in accordance with this Agreement, design and construction contracts, and all other applicable federal, state, and local laws and regulations.

2.2.6. If Metro issues the change order pursuant to Section 2.2.1, complete the North Portal in accordance with the MOA, the terms of which shall be incorporated into this Agreement as if set forth in full.

2.2.7. If the Parties agree, provide staff, consultants, and contractors deemed necessary and appropriate to manage, administer, coordinate, and oversee engineering, design, and construction management of the North Portal.

2.2.8. Cause the Project Contractor to design and construct all necessary changes to the interior Station walls and platform to accommodate the North Portal, the cost of which will be shared by the Parties in accordance with Sections 2.4 through 2.6.

2.2.9. Establish, jointly control with the City, and distribute funds from the joint account where the Parties will deposit project-related funds pursuant to Sections 2.4 through 2.6 ("**Project Account**").

2.3 **Joint Responsibilities of Metro and the City.** The City and Metro agree to cooperate on the following responsibilities:

2.3.1. The City shall be the lead agency and oversee the preparation of the environmental document. At the City's request Metro may provide responses to comments on the Draft EIR, the Final EIR, and the mitigation monitoring and reporting program. Prior to finalizing the following items, if necessary, appropriate representatives of both Parties shall confer on the following items, prior to the City's approval, in order to ensure consistency and facilitate accurate analysis of the North Portal project:

- Project description;
- Draft EIR and any technical studies and appendices;
- Proposed mitigation measures;
- Proposed project alternatives, including a “no project” alternative;
- Proposed responses to comments; and
- Mitigation monitoring and reporting program.

As the lead agency, the City’s decision to approve or deny the North Portal, and the City’s determinations pursuant to CEQA, must reflect the lead agency’s independent judgment. Accordingly, in the event that the Parties cannot reach an agreement as to the items listed above, final responsibility and authority to approve such items and resolve all other questions concerning the content and quality of the environmental review of the North Portal lies in the City’s sole discretion.

2.3.2. Share and exchange design and construction documents as appropriate and necessary to facilitate the North Portal.

2.3.3. Mutually agree upon any material variance from the approved North Portal design and location.

2.4 Life of Project Budget. The Parties agree that the total gross estimated cost for completing the North Portal and opening the North Portal for customer service, plus a sufficient contingency, is Seventy-Eight Million Five Hundred Thousand Dollars (\$78,500,000) (“Life of Project Budget”). The Life of Project Budget is based on the following anticipated costs: environmental review, design, construction management, construction of the North Portal and related improvements, post-construction costs that may arise to address punch list items or defects, and any other necessary and appropriate costs to complete and open the North Portal for customer service (collectively, “Project Costs”). The Project Costs include the Parties’ respective labor costs, based on each Party’s labor cost standards including overhead, administrative costs, consultant and contractor costs, and costs of purchasing equipment and/or materials without markup of any kind. The Life of Project Budget also assumes inflationary cost escalations for each such item.

2.4.1. Unless the Parties agree otherwise, each Party shall contribute, and deposit into the Project Account, an amount equal to half of the Life of Project Budget in accordance with the schedule and terms set forth in Section 2.5 for the purpose of paying for the North Portal project.

2.4.2. If at any time a joint financial obligation of the Parties relating to the North Portal would cause the Parties to exceed the Life of Project Budget, such that the Project Account’s balance is insufficient to pay for the joint financial obligation, then the Parties shall meet and confer in good faith to develop strategies to either reduce costs or to contribute additional

funds to cover the budget shortfall. Neither Party shall act arbitrarily or capriciously in regard to their decision whether to contribute additional funds.

2.4.3. If the meet and confer process described in Section 2.4.2 does not result in sufficient cost savings or additional funds to cover the budget shortfall, then the Parties shall determine whether they still desire to complete the North Portal and make financial contributions toward the North Portal as follows:

2.4.3.1. If both Parties agree to pursue the North Portal, then each Party shall deposit equal amounts into the Project Account so that the Project Account's balance is sufficient to pay all pending and anticipated joint financial obligations of the Parties relating to the North Portal.

2.4.3.2. If the City determines to pursue the North Portal, but Metro does not, then Metro shall deposit the remaining portion of its half share of the Life of Project Budget, if any, into the Project Account and shall have no further funding obligations toward the North Portal.

2.4.3.3. If Metro determines to pursue the North Portal, but the City does not, then the City shall deposit the remaining portion of its half share of the Life of Project Budget, if any, into the Project Account and shall have no further funding obligations toward the North Portal.

2.4.3.4. If Neither Party agrees to pursue the North Portal, then neither Party shall have further funding obligations toward the North Portal and remaining funds in the Project Account shall be used to pay any remaining joint financial obligations and then returned to the Parties in accordance with Section 2.6.6.

2.5 Schedule of Deposits into the Project Account. Subject to the terms and limitations of the Life of Project Budget, the Parties shall contribute funds to the Project Account in accordance with the following terms:

2.5.1. Construction Contract Funding. Within thirty (30) days following the award of the Construction Contract for the North Portal, each Party shall deposit into the Project Account Ten Million Dollars (\$10,000,000.00) less each Party's approved credits in accordance with Section 2.5.2, but in no event shall each Party deposit less than Three Million Dollars (\$3,000,000.00). Thereafter, whenever the Project Account falls to One Million Dollars (\$1,000,000.00) or a Party receives an invoice for Project Costs in excess of the Project Account's balance, then within ten (10) days each Party shall deposit into the Project Account an additional Five Million Dollars (\$5,000,000.00) but not to exceed the Party's 50% share of the Life of Project Budget. Neither Party shall withhold its contributions to the Project Account for any reason not enumerated in the Agreement and pledge to never delay progress payments from the Project Account to its consultants or contractors.

2.5.2. Deposit Credits. Each Party may receive a credit against all or a portion of the initial deposit required by Section 2.5.1 by directly paying, or committing by contract to pay, a consultant or contractor retained by that Party for necessary services to environmentally review, design, or construct the North Portal. A Party wishing to obtain a credit pursuant to this

Section shall provide the other Party with an executed contract or contract modification specifying the amount to be paid for the services or an invoice indicating the services rendered and amounts paid by the Party for such services at least thirty (30) days prior to the deadline for making the initial deposit. If a contract or contract modification is provided, then a subsequent invoice for such contracted services shall be provided to the other Party within six (6) months of the deposit's due date; provided, however, that invoices may be provided every sixty (60) days thereafter if the services necessarily require more than six (6) months to complete. If an invoice is not provided in accordance with this schedule, then the unsatisfied portion of the credit shall be revoked and the remainder of the deposit will become immediately due and payable. The other Party shall approve the contract or invoice and associated credit, which approval shall not be unreasonably withheld.

## 2.6 Manner In Which Each Party Will Be Reimbursed For Costs.

2.6.1. The Parties shall be entitled to reimbursement from the Project Account for their respective Project Costs.

2.6.2. Metro will establish the joint Project Account at a reputable banking institution that is reasonably acceptable to both Parties (the "**Bank**"). The Parties shall be jointly responsible for the cost of any administrative or service fees charged by the Bank. The Joint Account shall be accessible to both Parties for reimbursements in accordance with the procedures described in this Section 2.6. The Bank will remit a reimbursement payment within thirty (30) days of receipt of an invoice fully executed by both Parties authorizing reimbursement for Project Costs.

2.6.3. Either Party may submit duly executed invoices to the Bank for reimbursement of Project Costs. Prior to doing so, the Party seeking reimbursement shall provide the other Party an invoice outlining the Project Costs to be reimbursed, along with a certification that the charges identified in such invoice qualify as Project Costs, were appropriate and necessary for completion of the North Portal, and had not previously been billed or paid. With respect to all undisputed amounts, within thirty (30) days from receipt of the invoice, an authorized representative of the Party not seeking reimbursement shall approve the invoice by duly executing the official copy. The Parties shall attempt to resolve any disputed amounts within sixty (60) days of receipt of the invoice, by which time the Party seeking reimbursement shall either remove or reduce the costs or the other Party's representative shall approve the invoice for reimbursement.

2.6.4. Within fifteen (15) days after each month-end, Metro shall provide the Parties with a monthly project accounting report detailing Project Costs and expenditures, remaining Life of Project Budget authority, and any anticipated budget shortfall. Either Party may request of the other Party copies of billing statements, invoices and other financial documents relating to the North Portal.

2.6.5. Funds deposited into the Project Account may only be used for Project Costs incurred in furtherance of the environmental review, design, and construction of the North Portal. All interest accruing to funds in the Project Account shall remain in the Project Account.

2.6.6. Once all invoices submitted by the Parties have been paid out of the Project Account and all other obligations relating to the North Portal are satisfied, any remaining funds in the Project Account shall be returned to the Parties in proportion to each Party's respective contribution of funds to the North Portal project. Notwithstanding the foregoing, if the Life of Project Budget is exceeded and one Party chooses to fund the remainder of the Project Costs, while the other does not, then the Party contributing the remainder of the Project Costs shall be entitled to receive all remaining funds in the Project Account upon final completion of the North Portal and acceptance by Metro into its system for customer service.

2.6.7. Any disputes regarding billing statements, invoices, or reimbursements to or from the Project Account shall be resolved pursuant to Section 7 of this Agreement.

2.7 North Portal Acceptance. The North Portal shall become part of Metro's system upon its completion and acceptance of the work by the Parties. At that time, Metro shall assume all obligations associated with the maintenance, repair, and operation of the North Portal to the same extent as any other portion of the Station and its appendages.

2.8 Station Opening. The North Portal shall not be closed, and shall be available for customer use, at all times that the Station is open for customer use for at least twenty-five (25) years beginning on the date that the North Portal is first opened for customer use, except for routine maintenance, repairs, cases of emergency, threats to public health or safety, or if necessary for construction of a joint development involving Metro, the City and/or a private developer.

3. Public Restrooms. The City and Metro jointly agree that public restrooms shall be made available for customer use. The Parties will bargain in good faith regarding the availability of public restrooms when the Station opens for public use, consistent with a Metro systemwide restroom policy to be adopted by the Metro Board of Directors. The City Council has approved this Agreement in good faith reliance on Metro's representation that public restrooms will be available for customer use when the Station opens, pursuant to a Board-adopted systemwide restroom policy. If public restrooms are not provided pursuant to a systemwide restroom policy, then Permanent public restrooms will be constructed and made available in connection with a future development that benefits from the Station's existence. Metro shall be solely responsible for the full cost of constructing and maintaining the restrooms, provided that it may cause a private party to construct or maintain the restrooms if the restrooms are included in a future development at the Station. Alternatively, the City may include the restrooms in connection with a future development located at 9393 and/or 9385 Wilshire Boulevard, in which case Metro will not be responsible for the cost of constructing and maintaining the restrooms.

3.1 Restroom Maintenance. The public restrooms provided by this Section 3 shall be fully plumbed in accordance with applicable technical codes, be designed and sited to match the context of the surrounding buildings and environment, and maintained in a manner and frequency to ensure they are clean and sanitary. Metro shall coordinate with the City on the final design of any permanent restrooms constructed on Station property pursuant to this Section 3. Metro shall be responsible for maintaining the bathrooms at its sole cost, unless the restrooms are incorporated into a development project at 9393 and/or 9385 Wilshire Boulevard. Restrooms may

be periodically unavailable for public use due to routine maintenance, repairs, cases of emergency, threats to public health or safety. The obligation in this Agreement to provide public restrooms expires twenty-five (25) years from the date that the Station is first opened for customer use.

4. **Rescue Equipment.** Metro shall reimburse the City for the cost of rescue equipment for use in the event of a tunnel emergency during construction or operation purchased for the City's Fire Department up to Two Hundred Fifty Thousand Dollars (\$250,000.00). Metro shall remit funds within thirty (30) days of receipt of the City's invoice for the equipment.

5. **Holiday Moratorium.** Notwithstanding the provisions in the MOA, Article XIII prohibiting work during a holiday moratorium without City Council approval, Metro shall be permitted to work during the 2020 holiday moratorium in accordance with the conditions set forth in Exhibit A, in order to complete the Project and the C1120 Contract in a timely manner. Notwithstanding the provisions of this Agreement and in accordance with the MOA, Metro, at its discretion, may request an exemption from holiday moratoria after 2020. The Parties will bargain in good faith regarding an exemption from the 2021 or 2022 holiday moratorium with City Council approval. Metro has approved this Agreement in good faith reliance on the City's representation that it will accommodate Metro's request to work during the 2021 or 2022 holiday moratorium, if reasonable.

6. **Station Excavation.** Notwithstanding the required construction lane configurations and work hours set forth in Articles XII and XIII of the MOA, respectively, the City herein authorizes Metro, pursuant to this Section 6, to excavate the Station box through the Station property at Wilshire/Reeves and through the deck panels installed over Wilshire Boulevard in accordance with the conditions set forth in Exhibit A and the terms below.

6.1 **Sound Wall Across S. Reeves Drive.** Metro may temporarily close S. Reeves Drive at Wilshire Boulevard to vehicular traffic solely during the excavation of the Station box, provided that a sound wall is erected across S. Reeves Drive north of the Sirtaj Hotel. This sound wall shall have a wall assembly of STC-25 or greater, and the ability to reduce noise by at least 5 dBA. Public information graphics acceptable in design to the City shall be placed on the south side of the wall. Unless approved by the City Council, the sound wall shall be promptly removed and S. Reeves Drive reopened to vehicular traffic when excavation of the Station box is complete and the 20 foot sound wall around the Reeves Staging Yard shall be reestablished. The City Council may approve further closures of S. Reeves Drive upon request by Metro.

6.2 **Compliance With Noise Standards.** Pursuant to Article XIV of the MOA, the City Council authorizes Metro to excavate the Station box at night as set forth in Exhibit A based on the noise study prepared by the Project Contractor and reviewed by Metro that concludes that the nighttime construction work can be conducted in compliance with the noise standards set forth in Article XIV of the MOA. The noise study and associated mitigation measures are incorporated herein and attached hereto as Exhibit B. If the Independent Compliance Monitor established under Article XVI of the MOA identifies an exceedance of such a noise standard, then Metro and the Project Contractor shall promptly discontinue the construction activity that caused the exceedance until additional mitigation measures, possibly including reduction of construction activities, are implemented to reduce noise levels below the applicable noise standard.

6.3 **Compliance with MOA.** Except as provided herein, all other provisions of the MOA remain in effect, including the noise standards set forth in Article XIV and remedies available to the City to enforce those standards.

7. **Dispute Resolution.** If a dispute, claim, disagreement or controversy (a "**Dispute**") arises in connection with this Agreement or the performance of obligations set forth herein, the Parties shall promptly attempt in good faith to resolve such Dispute by negotiation between officers of each Party who have authority to settle the controversy. Either Party may give the other Party written notice of any Dispute not resolved in the normal course of business. Within five (5) business days after delivery of the notice, the receiving Party shall submit to the other Party a written response. The notice and response shall include with reasonable particularity a statement of each Party's position and a summary of its reasons supporting that position. Within five (5) business days after delivery of the response, the officers of both Parties shall meet at a mutually acceptable time and place. Unless otherwise agreed in writing by the negotiating Parties, the above-described negotiation shall end at the close of the first meeting of officers described above ("**First Meeting**"). If the Parties agree to mediate the Dispute, such mediation shall be submitted to JAMS, or its successor, for mediation. After the First Meeting and, if applicable any mediation agreed to by the Parties, either Party may seek judicial relief in Los Angeles Superior Court.

Additionally, if either party believes that there is a threat to public health or safety, that party may immediately seek judicial relief in the Los Angeles Superior Court.

8. **Duty to Cooperate.** The Parties agree to engage constructively, actively and on an ongoing basis to maximize the effectiveness of the Project. This duty shall include the sharing of non-confidential information upon request.

9. **Joint Press Release.** Upon final execution of this Agreement, the Parties shall jointly release to the public the following written statement:

"The Los Angeles County Metropolitan Transportation Authority (Metro) and the City of Beverly Hills announced an agreement today that avoids further litigation by the City concerning the Purple Line subway extension to Century City. The Beverly Hills Unified School District is not a party to this settlement agreement.

The agreement calls for the joint development of a second portal to serve the Wilshire/Rodeo Station. This second portal will serve businesses and tourists who regularly travel to the City's business triangle. The settlement agreement also calls for public restrooms to serve Station customers.

"We are pleased with this agreement," said Metro Board Chair and Los Angeles Mayor Eric Garcetti. "It keeps this critically important project on track. We look forward to delivering it to the commuters and taxpayers of Los Angeles County in a timely manner."

"We are glad to be able to move forward as a partner with Metro in developing the region's mobility solutions and welcoming the subway to our city," said Beverly Hills Mayor Lester Friedman.

“Having secured federal matching funds to complete the Purple Line Extension, Metro is excited to bring rapid rail service to Westwood in time for the 2028 Summer Olympics,” said Phillip Washington, Metro’s CEO.

The Purple Line Extension will extend the subway from its current terminus at Wilshire Boulevard and Western Avenue to Westwood to be built in three phases. The first segment to Wilshire and La Cienega Boulevard and the second segment through downtown Beverly Hills to Century City are both under construction. The third segment travels to Westwood and ends at the VA Hospital. When complete, the subway will provide a 25-minute ride between downtown Los Angeles and Westwood.”

10. **Indemnity**. Each Party agrees to defend, indemnify and hold harmless the other Party, their officers, agents, elected officials and employees from all liability, claims, losses and demands, including defense costs and reasonable attorneys’ fees, whether resulting from court action or otherwise, arising out of the negligent acts or omissions of the defending Party, its officers, agents, or employees, in the performance of this Agreement. When negligent acts or omissions of one Party are specifically directed by another Party, the Party directing the negligent acts or omissions shall owe this defense and indemnity obligation to the Party following the directions. This clause shall not be construed to supersede or affect the Parties’ indemnity obligations to each other, as set forth in the MOA, with respect to any other aspect of the Project not specifically addressed in this Agreement. The provisions of this paragraph shall survive the termination of this Agreement.

11. **Priority of Agreements**. The following order of priority shall control in the event of a conflict between the provisions of these documents: (1) the body of this Agreement; (2) Exhibit A; (3) Exhibit B; and (4) the MOA.

12. **Effective Date**. The “Effective Date” shall be the date that this Agreement is fully executed.

13. **Further Assurances**. The Parties agree to enter into, deliver, perform, construe, and take any action under any contract, agreement, or other instrument that is reasonably necessary to effectuate this Agreement, and, except as otherwise provided in this Agreement, the City Manager and Chief Executive Officer shall have the authority to do so on behalf of the City and Metro, respectively.

14. **Parties’ Remedies**. Each Party expressly agrees that damages are an inadequate remedy for a breach of this Agreement and that all provisions of this Agreement shall be specifically enforceable by either affected party.

15. **Entire Agreement**. This Agreement, together with any exhibits attached hereto, contains the sole and entire agreement and understanding to which the Parties and any and all prior discussions, negotiations, commitments or understandings related hereto, if any, are merged herein and superseded hereby. No representations, warranties, promises, covenants, undertakings, commitments, restrictions, or other obligations, verbal, written or otherwise, expressed or implied, other than those expressly contained herein have been made by either Party to the other.



16. **Amendments; Waiver.** This Agreement may be amended only by an agreement in writing signed by both Parties hereto. No waiver of any provision or consent to any exception to the terms of this Agreement shall be effective unless in writing and signed by the Party to be bound, and then only for the specific purpose, extent, and instance so provided. Failure on the part of any Party to enforce any of its rights under this Agreement shall not be construed as a waiver of such rights, and a waiver by any Party of a default hereunder in any instance shall not be construed as constituting a continuing waiver or as a waiver in other instances.

17. **No Release.** Nothing set forth in this Agreement shall constitute a waiver or release of claims by either Party for compensation and/or damages arising from the Project.

18. **Notices.** Any notice, demand, or other communication of any kind, whatsoever, that any of the Parties may be required or may desire to give to or serve upon any of the other Parties shall be given in writing and (i) delivered in person (including express or courier service), or (ii) mailed by certified or registered mail, postage prepaid, return receipt requested, addressed as follows:

**If to Metro:**

Los Angeles County Metropolitan Transportation Authority  
One Gateway Plaza  
Mail Stop: 99-17-20  
Los Angeles, California 90012  
Attention: Richard Clarke

**With a copy to:**

Los Angeles County Metropolitan Transportation Authority  
County Counsel  
Transportation Division  
One Gateway Plaza  
Mail Stop: 99-24-20  
Los Angeles, California 90012  
Attention: Ronald W. Stamm, Esq.

**If to the City:**

City Manager  
Beverly Hills City Hall  
455 N. Rexford Dr., 4th Floor  
Beverly Hills, CA 90210

**With a copy to:**

City Attorney  
Beverly Hills City Hall  
455 N. Rexford Dr., Room 230  
Beverly Hills, CA 90210

Richards, Watson & Gershon  
350 South Grand Avenue, 37th Floor  
Los Angeles, California 90071-3101  
Attn: Laurence S. Wiener, Esq.

or to such other address or to such other person as any Party shall have last designated by such notice to the other Party. Each such notice, demand, or other communication, if addressed as aforesaid and delivered in person, shall be effective only when actually delivered to such addressee. Each such notice or communication, if addressed as aforesaid and transmitted via either certified or registered mail, shall be effective upon the date of delivery, whether or not accepted by addressee.

19. **Voluntary Agreement; Representation by Counsel.** This Agreement is executed voluntarily by each of the Parties hereto without any duress or undue influence on the part of, or on behalf of, either of them. The terms of this Agreement have been negotiated by the Parties, and the language of the Agreement shall not be interpreted under presumptions in favor of or against any particular Party. Each of the Parties hereto represents and warrants to each other Party that it has read and fully understands the provisions of this Agreement and has had the opportunity to discuss the same with legal counsel of its own choosing. Each of the Parties hereto further represents and warrants to the other Party that its officers or other representatives who sign this Agreement on its behalf are authorized to do so and to bind that Party, both by consent of that Party and under applicable law, and that they are executing this Agreement pursuant to that authority. The Parties, and each of them, acknowledge that each has been represented in the negotiations for and in the performance of this Agreement by counsel of its own choice; that the Parties have read this Agreement; that the Parties have had this Agreement, and each of its terms, fully explained by such counsel or have had such opportunity; and that each Party is fully aware of the contents of this Agreement and of its legal effect.

20. **Binding Effect.** This Agreement shall bind, and inure to the benefit of, the Parties' respective successors and representatives.

21. **Assignment.** The rights and obligations of Metro under this Agreement shall not be assigned and any attempted assignment shall be void and of no effect. The rights and obligations of the City under this Agreement shall not be assigned and any attempted assignment shall be void and of no effect.

22. **Governing Law.** The validity, interpretation, effect, and enforcement of this Agreement, or any portion thereof, shall be governed by, and shall be construed and enforced in accordance with, the laws of the United States and the State of California, as applicable.

23. **No Third-Party Beneficiaries.** Nothing in this Agreement is or shall be construed to be intended to benefit any third party, or create any third-party beneficiary and no third party or parties shall have any claim or right of action under this Agreement for any cause whatsoever. Notwithstanding the foregoing, FTA is a third-party beneficiary of this Agreement.

24. **Authorization to Sign.** The persons executing this Agreement on behalf of Metro and the City, respectively, each represent and warrant that he or she is duly authorized to execute same on behalf of its Party.

25. **Counterparts.** This Agreement may be executed in one or more counterparts, each of which shall be deemed an original agreement, but all of which together shall constitute one agreement.

26. **Time of Essence.** Time is of the essence of every provision hereof in which time is a factor.

27. **Usage.** Unless stated otherwise, the term “day” or “days” shall refer to calendar days.

[Signature page follows]

IN WITNESS WHEREOF, the Parties have caused this Agreement to be duly executed by their duly authorized representatives as of the Effective Date.

**“Metro”**

Los Angeles County Metropolitan Transportation Authority

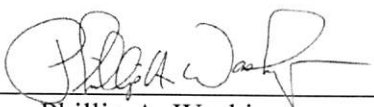
By:   
Name: Phillip A. Washington  
Title: Chief Executive Officer

Date: November 19, 2020

**“City”**

City of Beverly Hills

By:   
Name: LESTER J. FRIEDMAN  
Title: Mayor of the City of Beverly Hills, California

Date: December 10, 2020

ATTEST:

 (SEAL)  
HUMA AHMED  
City Clerk

Approved as to Form:

  
LAURENCE S. WIENER  
City Attorney

Approved as to Form:

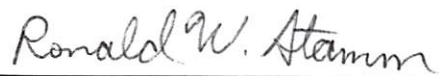
  
RONALD W. STAMM  
Principal Deputy County Counsel

## **Exhibit A**

### **Conditions of Approval for Excavation Work and Work During 2020 Holiday Moratorium**

**The following conditions apply until the earlier of June 30, 2021, or when restaurants within the City of Beverly Hills are permitted by applicable public health orders to provide indoor dining at 100% capacity:**

#### **Traffic Control**

- S. Reeves can be Closed between Wilshire Blvd and the Alley south of Wilshire Blvd.
  - At the completion of excavation of station box, S. Reeves closure to end with complete opening of S. Reeves and 20' minimum sound walls to be reestablished around Reeves Staging Yard w/ Public Information Graphics.
- Wilshire can be configured to two lanes in each direction with K-rail with sound walls (extended Staging Yard)
  - All walls to have Public Information Graphics and/or Holiday Themed Public Information Graphics per City (see Public Information Graphics below). The sound wall protection currently in effect will satisfy this noise requirement.
- Wilshire can be configured to one lane in each direction, allowing for access to deck panels at Beverly and S. Canon
  - 12am to 10:45am. Only traffic control set up may occur between 12am and 1am.
- All other traffic control must meet MOA conditions but at no time shall there be work/traffic control in Wilshire Blvd between 4pm and Midnight. This excludes the extended Reeves Staging Yard traffic control described above.

#### **Work Activities**

- Excavation, Material removal and Hauling - Access through Deck Panels on Wilshire
  - Weekdays and Weekends
    - 12am to 10:45am. No surface work activities (i.e. excavation/hauling) to start before 1am. Only traffic control set up to occur between 12am and 1am.
      - Per the MOA, Nighttime noise control plan must be approved by City Council.
- Excavation, Material removal and Hauling – Within Extended Reeves Staging Yard Area (Behind K-rail Setup with Reeves Closed)
  - Weekdays
    - 7am to 4pm and 1am to 7am
      - Per the MOA, Nighttime noise control plan must be approved by City Council for work between 1am and 7am.
  - Weekends
    - 8am to 4pm and 1am to 8am

- Per the MOA, Nighttime noise control plan must be approved by City Council for work between 1am and 8am.
- Material Delivery and Utility Maintenance - Access through Deck Panels on Wilshire
  - Weekdays and Weekends
    - 12am to 10:45am. No surface work activities (i.e. material delivery/utility maintenance) to start before 1am. Only traffic control set up to occur between 12am and 1am.
      - Per the MOA, a noise control plan must be approved by City staff.
- Material Delivery and Utility Maintenance – Within Extended Reeves Staging Yard Area (Behind K-rail Setup with Reeves Closed)
  - Weekdays
    - 7am to 4pm and 1am to 7am
      - Per the MOA, Nighttime noise control plan must be approved by City Staff for work between 1am and 7am.
  - Weekends
    - 8am to 4pm and 1am to 8am
      - Per the MOA, Nighttime noise control plan must be approved by City Staff for work between 1am and 8am.
- Engineering (Survey/Potholing/Geotechnical Borings/Instrumentation & Monitoring) outside the Triangle east of Crescent.
  - 7am to 4pm Weekdays on Wilshire
  - 8am to 4pm Weekdays off Wilshire

### **Public Information Graphics**

- Public Information Graphics and/or Holiday Themed Public Information Graphics must be installed as identified and specifically requested by the City on all fencing and/or walls proposed if feasible.
- Santa Display shall be erected and hung by the City at Beverly Dr. and Wilshire Blvd., as in past years, at a time designated by the City. No work activities shall substantially degrade the existing physical quality or character of the Santa Display until the Santa Display is removed by the City.

### **Holidays**

- No work to occur on Thanksgiving, Friday after Thanksgiving, Christmas Eve, Christmas, New Year's Eve, New Year's Day, 1st night of Hanukkah (Dec. 10, 2020). Traffic control associated with the Extended Reeves Staging Yard are permitted to remain in place on these holidays during excavation.
- If there is a City Event (i.e. Holiday Bold, Awards Event, etc.), No work can occur during planned City Sponsored Events.

### **Independent Compliance Monitor**

- Compliance would be monitored and enforced by the ICM in accordance with the MOA.

**Exhibit B**  
**Approved Noise Study**

**MTA PURPLE LINE SECTION 2 PROJECT  
NOISE CONTROL PLAN MOA CONDITIONS  
Wilshire/Rodeo Station Excavation**

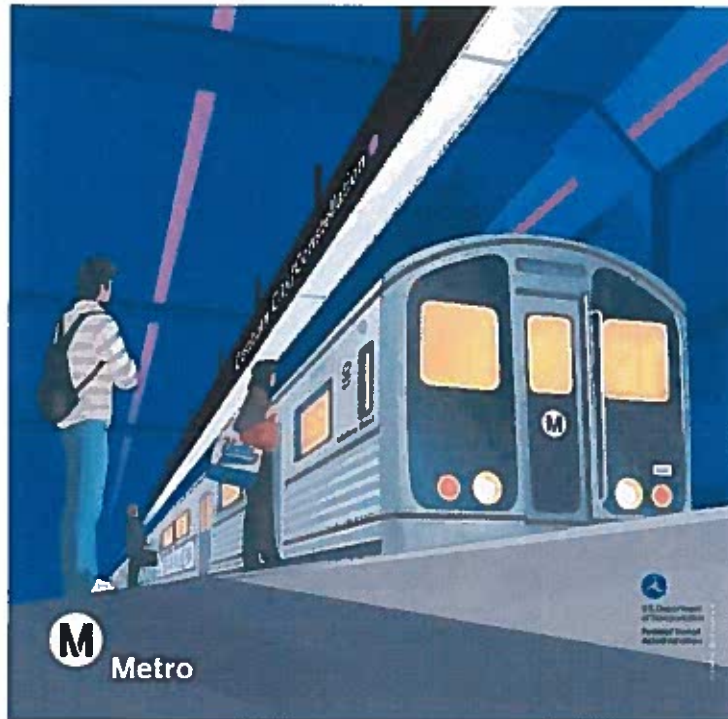

November 3, 2020

Submitted by:



*Engineered Solutions*

Submitted to:

**TUTOR PERINI/O&G, JV**

**1801 Century Park East, Ste. 500**

**Los Angeles, CA 90067**







## Contents

1. Introduction.....	3
2. Construction Schedule.....	3
3. SoundPLAN.....	3
4. Noise Control Plan .....	5
4.1 Construction Equipment .....	5
4.2 Site Plan and Discussions .....	5
4.3 Results and Observations .....	9
5. Mitigation Measures .....	13
APPENDIX A- SITE PLAN SCHEMATIC .....	14
APPENDIX B- Noise Certification for Excavator .....	16
APPENDIX C- Noise Certification for Ventilation Fans – For Reference Only.....	17
APPENDIX D – Metal Grate Sound Profile.....	19
APPENDIX E - RESULTS.....	23



## 1. Introduction

The aim of this study is to analyze and predict the construction noise levels during excavation through a limited opening and hauling operations at Wilshire Blvd & S. Canon Dr. The excavation site is in front of 9378 Wilshire Blvd. The site is surrounded by high rise office spaces alongside Wilshire Blvd and Canon Drive. The residential buildings are located to the east and south of the excavation site. Commercial structures are located to the south as well as north across Wilshire Blvd.

## 2. Construction Schedule

The excavation work will commence in 2020.

## 3. SoundPLAN

The sound model for the excavation was developed for continuous noise generation during the daily work shifts. *SoundPLAN* was configured with settings outlined in Table 1. The noise modelling was performed using *SoundPLAN* version 8.1, which calculates outdoor noise propagation based upon the methodology specified in ISO 9613 -2.

Table 1 *SoundPLAN* Noise Prediction Model Settings

<b>Prediction Model:</b>	ISO 9613 -2 "Acoustics -- Attenuation of sound during propagation outdoors -- Part 2: General method of calculation", 1993
<b>Air absorption:</b>	ISO 9613-1 "Acoustics -- Attenuation of sound during propagation outdoors -- Part 1: Calculation of the absorption of sound by the atmosphere"
<b>Environment:</b>	
Air pressure	1013 mbar
rel. Humidity	70%
Temperature	25 °C = 77 °F
<b>Maximum Screening Loss:</b>	
<b>Assessment:</b>	Leq
<b>Frequency Weighting:</b>	dBA
<b>Ground:</b>	Reflective Ground g=0



Note:

- The accuracy of a noise model depends on several parameters such as source input (sound power level, spectral content, operation consideration), modeling standard settings, and noise prediction parameters.
- The excavation area was modeled using the *SoundPLAN* noise modeling software. The prediction uses the ISO 9613 -2 [Acoustics -- attenuation of sound during propagation outdoors -- Part 2: General Method of Calculation", 1993] prediction standard. *SoundPLAN* follows and meets the requirements developed for quality assurance of software implementation of ISO 9613-2 [ISO 175343 Acoustics -- software for the calculation of sound outdoors -- Part 3: Recommendations for quality assured implementation of ISO 9613-2].
- The ISO 9613-2 standard was developed with slight downwind and inversion condition which typically overpredicts than under-predict the noise levels. The FHWA emission data do also tend to be conservative and overestimate the equipment noise generation.
- Regarding the overall predicted sound level, the model assumes that all equipment operates at the same time, which is a conservative prediction process.
- The equipment sound power level inputs were based on measured data provided by TPOG, Specification 01 56 19 and data published by FHWA - Table 1. Construction Equipment Noise Emission Levels ([https://ops.fhwa.dot.gov/wz/workshops/accessible/Schexnayder\\_paper.htm](https://ops.fhwa.dot.gov/wz/workshops/accessible/Schexnayder_paper.htm)). The FHWA data typically does not reflect the newest noise control technology and provide a conservative assessment with higher input sound power levels.



## 4. Noise Control Plan

The noise control plan was developed based on the situation below:

Excavation and Hauling operational for 24 hours/day. Excavation site is surrounded by 12 ft noise barrier with all equipment operating simultaneously. However, for the noise model different utilization factors for the equipment were considered, as shown in the Table 2, below.

Terex RT 780 Crane will be in operation at Wilshire and Beverly Drive within a 12 feet high Noise Barrier.

To account for cumulative noise at sensitive receivers, the ventilation fan installed in the Canon Yard was also added to the noise model. A 14 feet high Noise barrier is added around the Ventilation fan.

If current excavation location is modified or if addition locations are added, Noise Control Plan will be updated accordingly.

The noise control plan will be updated quarterly.

### 4.1 Construction Equipment

Construction equipment list shown in Table 2 was used for the model development.

Table 2. Sound Power Levels

Name	Lw (dbA)	Noise Levels @ 50 ft (dbA)	Utilization
Dump Trucks (Height 12 ft)	105	75	66%
Haul Route (Height 12ft, Speed 20mph)	105	75	Noise Exposure -10%***
Excavator (Height 8 ft)	109	79	100%
Terex Rough Crane Rt 780 (Height 8 ft)	111	81	95%
Ventilation Fans**(Height 3 ft)	112	82	100%
Ventilation Metal Grate -- Modeled as two separate point sources* (At ground Elev)	89	59	100%

- Note: Noise Levels at 50 ft were provided by TPOG, Equipment are not subjected to requirements beyond specification 01 56 19
- \*Noise Power Levels for Metal grate was calculated by using the Noise Measurement Data provided by Metro, Noise Silencer was used to reduce the noise from the intake, see Appendix
- Please refer to Appendix C for Noise Certification, \*\*\* Equipment Noise Certification for ventilation fans is attached in Appendix D.
- Note: The sound Power Levels were calculated from the Noise Levels @50 ft as shown in the table below ( $L_w = L_{50} + 20 \log(50 \times 0.3048) + 8$ )
- \*\*\*The Noise Exposure from Haul route is calculated at 20 mph. The trucks are anticipated to pass the sensitive receivers every 5 minutes, adding noise exposure for 30 seconds for each receiver or 90 seconds every 15 mins or 10%.

### 4.2 Site Plan and Discussions

The Baseline Model for situation is shown Figure 1, it includes all equipment that would be operational during excavation. Noise Sensitive locations as per MOA conditions are shown in Figure 2. The staging area is highlighted in purple.



The 14 high Noise Barrier (NRC=0.85) is indicated as the blue boundary around the excavator and dump truck on the Wilshire Blvd. The Noise Barrier height was increased to a total of 15 feet on east section to shield receptor RD-11 from noise. The loading trucks will enter through the west section of the closure. The Noise wall will remain closed except during the trucks entering the work area and hence, the Noise Wall was modeled as a continuous sound barrier.

Excavator operation inside the closure at Wilshire Blvd was modeled as the area source and Dump Truck was added as a point source. Haul route is added as the line source with trucks travelling at a speed of 20 mph.

Along with the Haul Route, excavator, and dump trucks a ventilation fan was also added in the noise control plan at Canon Yard. A 20ft high noise wall is installed around the Canon Yard, also shown in green in Figure 2. An additional 14 feet high noise wall was modeled around the Ventilation Fan as shown in figure 1. The maximum operational noise value for the ventilation fans shall be 82 dBA at 50 feet per the noise certificate attached in the appendix.

A 100% utilization factor or 24-hour operation was assumed for the Ventilation Fan. The Utilization factors for Excavator was added as 100% to mimic continuous operation for 24h. The average travel speed from 9355 Wilshire Blvd. to 9555 Wilshire Blvd was added to be 20mph. Average time of truck idling was estimated to be 10 min every 15 min; hence, the Utilization Factor is calculated as 66 %.

The noise exposure from the haul route will be around 90 seconds for 15 minutes interval considering 30 seconds exposure during each 5 minutes dump cycle.

Crane operation at Wilshire/Beverly Dr was included was modeled with 12 feet Noise Barrier around the crane and dump truck.

Ventilation intake located at Wilshire/Beverly Dr. was also included in the noise model. The Sound Power Levels for the Ventilation grate were calculated from the noise measurement provided by Metro (see Appendix). The ventilation intake was modeled as two-point source to match the noise profile provided by the measurement results.

The residential buildings are shown in blue on figure 1; hotels are shown as light green; and commercial buildings and residential buildings are shown in shades of grey. The buildings were modeled at their full height; varying floor heights were identified.

To calculate the Noise Levels at different heights, noise receptors were added on all façades of the buildings.



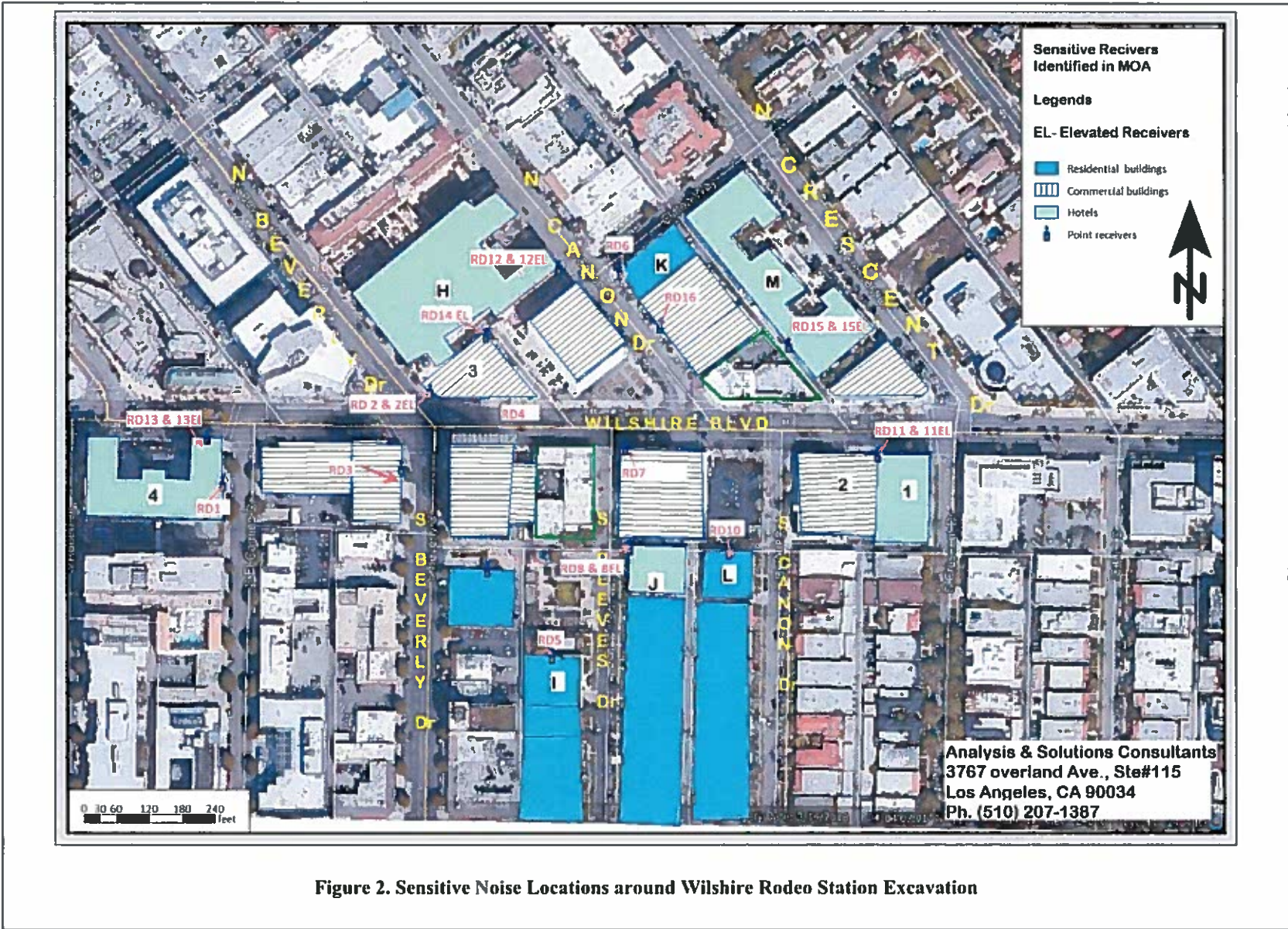

Figure 2. Sensitive Noise Locations around Wilshire Rodeo Station Excavation

#### 4.3 Results and Observations

Noise predictions for 24 h are presented in Appendix B. Threshold limits at the receivers established by Ambient Noise Study (submitted previously) are used for comparing predicted noise levels.

Based on the assessment of the results, RD-2, RD-3, RD-13, RD-10, RD-11 RD-15, and RD-16, receptors will be directly affected by the construction activities. However, the predicted noise levels for these receptors are within the noise level threshold. The noise levels should be closely monitored to avoid any exceedance during the nighttime work hours.

RD-15 – receptor RD 15 is located directly to the east of the Canon Yard Canon Yard. While ground level is properly shielded from the Noise Levels by 20 ft high Noise Barrier, the elevated receptor may be affected by the construction equipment, specially Ventilation Fan and dump trucks. A 14 feet Noise Barrier is also required around the Ventilation Fan. The ideal location for the fan would be around the middle portion of the yard.

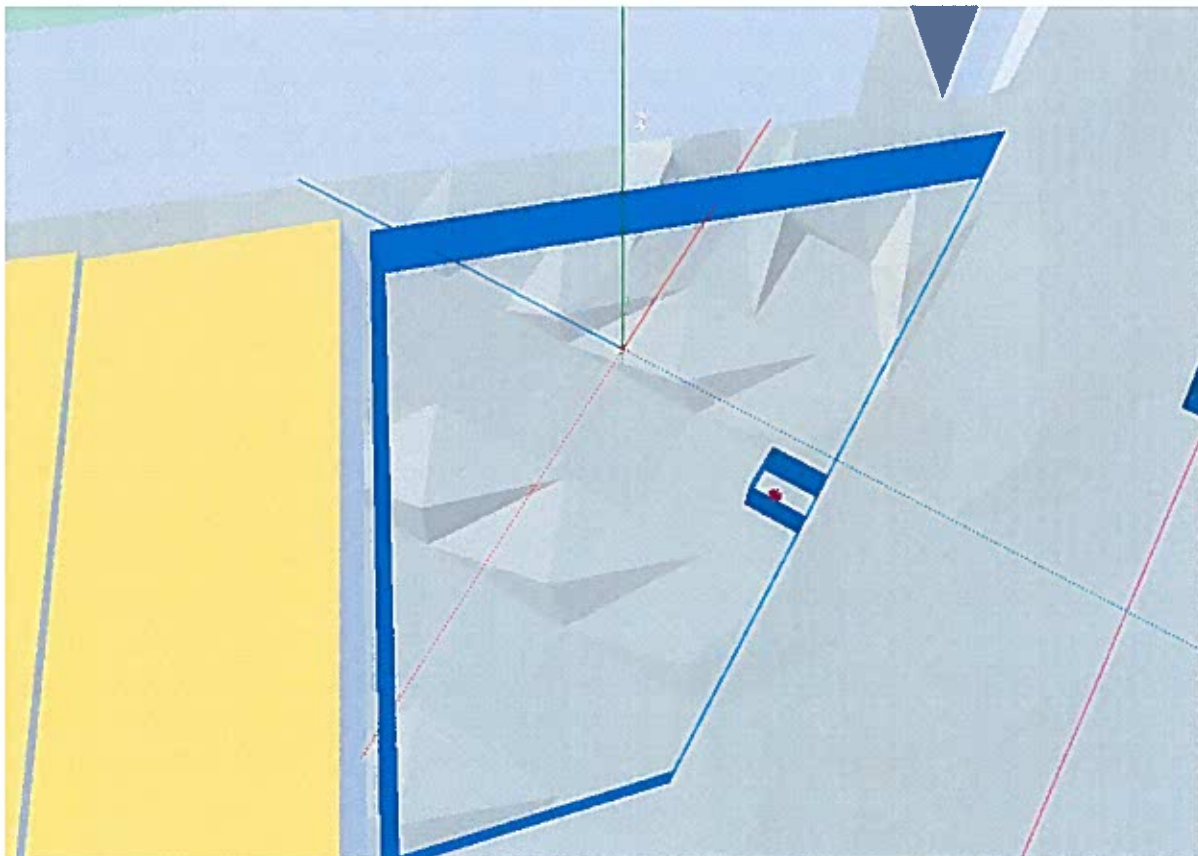

Figure 3. Ventilation Fan setup at Canon Yard (Colors do not represent any noise values)



RD -11 is located to the east of the work area on Wilshire Blvd and is directly exposed to the noise levels from the construction.

A 15 feet high Noise barrier along the east boundary and, 14 feet high barrier along north, south and west section of the work area will be required to shield the RD-11 Elevated receptor from the construction Noise during the Night Time work as shown in the figure below.

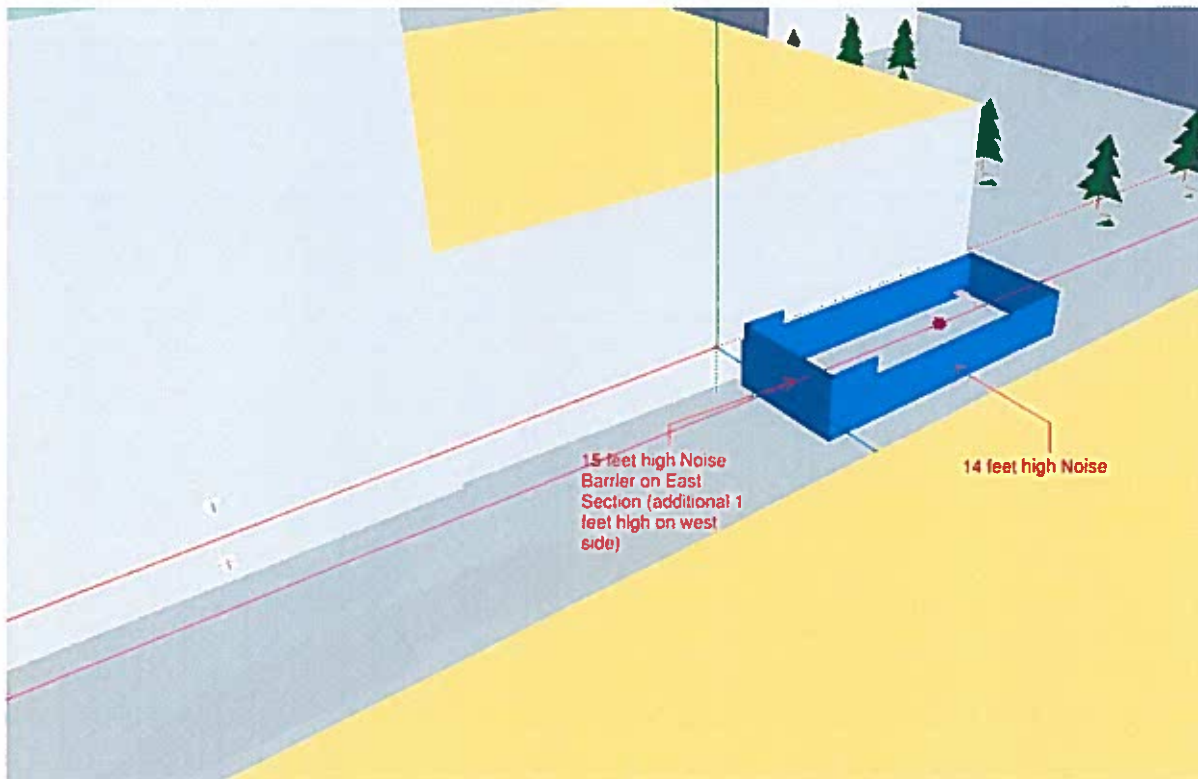

Figure 4. Noise Enclosure around work area (Colors do not represent any noise values)

Another critical receptor for this construction work is RD-10 which is located to the south west for the work on Wilshire. This receptor will be closely monitored for noise trends and equipment utilization shall be reduced by 10% or less if the noise levels more than the predicted levels are recorded during the construction work.

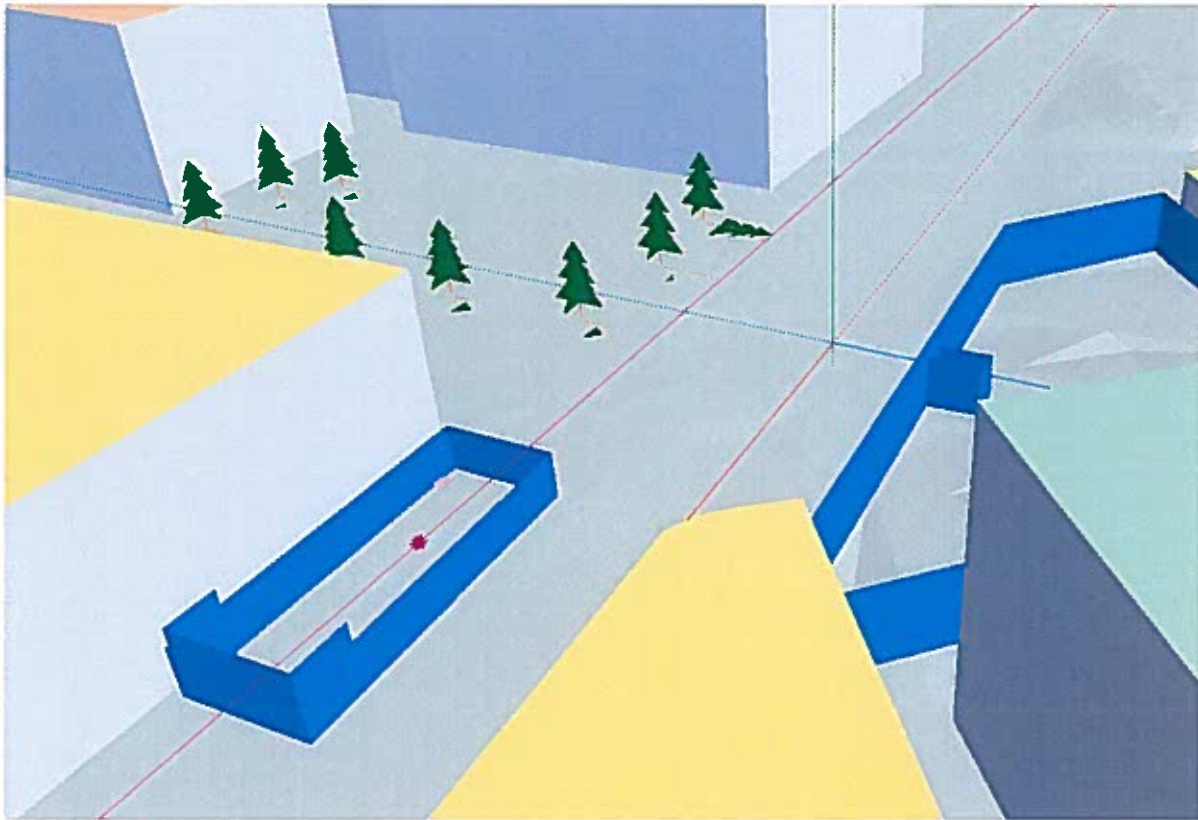

Figure 5. Receptor RD-10 (Colors do not represent any noise values)

Due to given vicinity of the RD-7 and RD-16 from the staging yards, they should be closely monitored for any exceedances.



Figure 6. Predicted Noise Levels –Contour Plot for Noise propagation at Ground Level (Receptor color indicate maximum façade noise level)

## 5. Mitigation Measures

Based on the simulations following mitigation measures will be taken:

- 1) Excavation area will be surrounded by 14 ft noise barrier (NRC= 0.85) with 15 feet additional noise barrier east of the excavation area as discussed in the section above.
- 2) Equipment utilization shall be reduced by 10% to meet the noise threshold if the trend at any of the receptors seems to approach toward exceedance
- 3) Completely switch off dump trucks during loading and idling.
- 4) If during noise monitoring Lmax level exceeds the threshold value following actions will be taken:
  1. Contractor shall switch equipment to meet noise requirements. OR
  2. Contractor shall modify work hours to meet noise requirements. OR
  3. Contractor shall use other available noise reduction measures.
- 5) Noise from a construction activity and/or construction equipment shall comply with all noise requirements identified in Article XIV of the MOA, which includes the Lmax noise limits. If the activity, the equipment in use and/or the sound enclosure for the equipment are modified or the equipment is operated at a location not identified in the noise control plan, the noise control plan shall be revised to address the changed conditions and resubmitted to the City for review and approval. The use of non-compliant equipment and/or engaging in a construction activity that exceeds the MOA identified noise limits including Lmax noise level shall not continue until the City approves a noise control plan revision and/or the implementation of noise mitigation to ensure that the equipment complies with noise limits identified in Article XIV.”
- 6) To reduce noise levels at Wilshire / Beverly intake grate, install additional silencer at each intake fan, see Appendix D for silencer product data



## APPENDIX A- SITE PLAN SCHEMATIC





## APPENDIX B- Noise Certification for Excavator

FIGURE 3

### EQUIPMENT NOISE LEVEL DATA REPORTING FORM

#### APPLICATION FOR CERTIFICATE OF EQUIPMENT NOISE COMPLIANCE

Contractor Name: TPOGJV  
 Contract Name & Number: Tutor Perini and O&G JV  
 Equipment Type: Excavator  
 Manufacturer & Model Number: CAT 390  
 Identification Number: FHHNG00186  
 Rated Power & Capacity: 405 HP  
 Operating Condition During Test: (Specify, Record, or Note all test conditions. If none, write "None")

Measured Sound Levels at 20 to 50 feet:

Measured Values and Distance:

Right Side: 74.4 dBA (SLOW) at 50 feet  
 Left Side: 74 dBA (SLOW) at 50 feet

Estimated Values at 50-Foot Distance:

Right Side: \_\_\_\_\_ dBA (SLOW).  
 Left Side: \_\_\_\_\_ dBA (SLOW).

Maximum Values Allowed for this Equipment: 81 (See per 800's 01 56 10) dBA (SLOW) at 50 feet.

If equipment sound level exceeds maximum value allowed, indicate action taken to achieve compliance:

\_\_\_\_\_

\_\_\_\_\_

Name, Address & Phone No. of Acoustical Engineer: Dr. Dots Oyenuka, 3767 Overland Avenue, Los Angeles 90034, Suite 115, +1-510 207 1387

Authorized Signature: \_\_\_\_\_ Date: 6/12/20  
 CONTRACTOR'S APPROVAL:  
 Authorized Signature: \_\_\_\_\_ Date: \_\_\_\_\_  
 ENGINEER'S CONCURRENCE:  
 Authorized Signature: \_\_\_\_\_ Date: \_\_\_\_\_



# APPENDIX C- Noise Certification for Ventilation Fans – For Reference Only

## EQUIPMENT NOISE LEVEL DATA REPORTING FORM

### APPLICATION FOR CERTIFICATE OF EQUIPMENT NOISE COMPLIANCE

Contractor Name: TPOG  
Contract Name & Number: MTA Purple line Extension 2 , C1120

Equipment Type: Ventillation Fan  
Manufacturer & Model Number: R-5300-B-SS-XP  
Identification Number: 300 HP  
Rated Power & Capacity: \_\_\_\_\_  
Operating Condition During Test: Sunny, Clear Sky

#### Measured Sound Levels at 20 to 50 feet:

Measured Values and Distance: There were obstructions blocking the right side of the ventilation fans, as a result of which the noise level for right side is lower than the left.

Right Side: 76.4 dBA (SLOW), at 50 feet  
Left Side: 82.4 dBA (SLOW), at 50 feet

#### Estimated Values at 50-Foot Distance:

Right Side: \_\_\_\_\_ dBA (SLOW).  
Left Side: \_\_\_\_\_ dBA (SLOW).

Maximum Values Allowed for this Equipment: 85 dBA (SLOW) at 50 feet.

**Note:** Equipment was operated at maximum governed rpm under full load conditions during the tests. All tests were performed under the supervision of the Acoustical Engineer.

If equipment sound level exceeds maximum value allowed, indicate action taken to achieve compliance:  
\_\_\_\_\_  
\_\_\_\_\_

Name, Address & Phone No. of Acoustical Engineer: Dr. Dots Oyenuga, 3767 Overland Avenue, Suite # 115, (510) 207 1387

Authorized Signature:  Date: 02/20/20

CONTRACTOR'S APPROVAL: \_\_\_\_\_ Date: \_\_\_\_\_

Authorized Signature: \_\_\_\_\_ Date: \_\_\_\_\_

ENGINEER'S CONCURRENCE: \_\_\_\_\_ Date: \_\_\_\_\_

Authorized Signature: \_\_\_\_\_ Date: \_\_\_\_\_





# JETAIR

A Division of Mining Equipment Limited

JETAIR FANS  
P.O. BOX 2114  
DURANGO CO. 81302  
PH. (970) 259-8412  
www.jetairfans.com

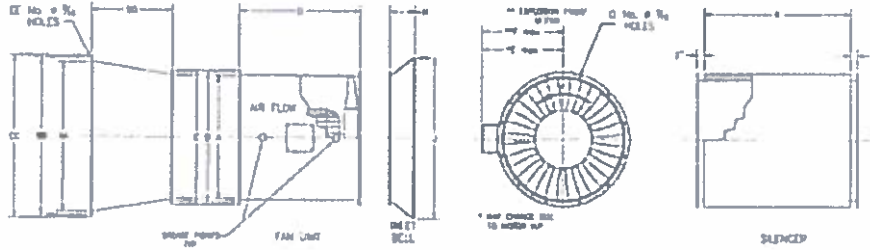

SINGLE STAGE FAN WITH ADJUSTABLE PITCH

Capacity (CFM)	Flange Dia.	Outlet Dia.
10 - 1000	30	34
40 - 4000	30	34
80 - 8000	34	38

CASE		FAN UNIT															INLET BELL		SILENCER		CASE DIA.	
Dia.	HP	Please call for Dia. F															H	L	W	D		
		HP	Q	C	D	E	G	AA	BB	CC	DD	EE	FF	GG	HH	II						
18	2-14	1000	14	18.78	21.25	28	17	17	22	23.78	29.24	17	12	9	17.17	28	16					
21.54	10-20	2000	17	21.18	24.93	30	19	17	24	27.74	33.24	14	12	4.17	27.89	42	21.14					
23.54	10-20	2000	14.71	23.14	26.94	30	19	17	20	26.14	31.24	14	12	9	28.14	48	23.14					
25.14	10-20	2000	14.71	23.14	26.94	30	19	17	20	26.14	31.24	14	12	8.12	27	30	25.14					
27.14	20-30	3000	14.71	23.14	26.94	30	19	17	20	26.14	31.24	14	12	9	28.14	34	27.14					
29.14	20-30	3000	14.71	23.14	26.94	30	19	17	20	26.14	31.24	14	12	8.14	28	30	29.14					
31.14	30-40	4000	21	21.14	26.94	42	21	12	22	22	22	22	12	9.14	30	41	31.14					
33.14	30-40	4000	21	21.14	26.94	42	21	12	22	22	22	22	12	9.14	30	41	31.14					
35.14	40-50	5000	14.71	23.14	26.94	30	19	17	20	26.14	31.24	14	12	8.14	28	30	35.14					
37.14	40-50	5000	14.71	23.14	26.94	30	19	17	20	26.14	31.24	14	12	7.12	27	32	37.14					
39.14	50-60	6000	21.28	21.28	26.94	42	21	12	22	22	22	22	12	9	30	34	39.14					
41.14	50-60	6000	21.28	21.28	26.94	42	21	12	22	22	22	22	12	9	30	34	41.14					
43.14	60-70	7000	21.28	21.28	26.94	42	21	12	22	22	22	22	12	9	30	34	43.14					
45.14	60-70	7000	21.28	21.28	26.94	42	21	12	22	22	22	22	12	9	30	34	45.14					
47.14	70-80	8000	21.28	21.28	26.94	42	21	12	22	22	22	22	12	9	30	34	47.14					
49.14	70-80	8000	21.28	21.28	26.94	42	21	12	22	22	22	22	12	9	30	34	49.14					
51.14	80-90	9000	21.28	21.28	26.94	42	21	12	22	22	22	22	12	9	30	34	51.14					
53.14	80-90	9000	21.28	21.28	26.94	42	21	12	22	22	22	22	12	9	30	34	53.14					
55.14	90-100	10000	21.28	21.28	26.94	42	21	12	22	22	22	22	12	9	30	34	55.14					
57.14	90-100	10000	21.28	21.28	26.94	42	21	12	22	22	22	22	12	9	30	34	57.14					
59.14	100-110	11000	21.28	21.28	26.94	42	21	12	22	22	22	22	12	9	30	34	59.14					
61.14	100-110	11000	21.28	21.28	26.94	42	21	12	22	22	22	22	12	9	30	34	61.14					
63.14	110-120	12000	21.28	21.28	26.94	42	21	12	22	22	22	22	12	9	30	34	63.14					
65.14	110-120	12000	21.28	21.28	26.94	42	21	12	22	22	22	22	12	9	30	34	65.14					
67.14	120-130	13000	21.28	21.28	26.94	42	21	12	22	22	22	22	12	9	30	34	67.14					
69.14	120-130	13000	21.28	21.28	26.94	42	21	12	22	22	22	22	12	9	30	34	69.14					
71.14	130-140	14000	21.28	21.28	26.94	42	21	12	22	22	22	22	12	9	30	34	71.14					
73.14	130-140	14000	21.28	21.28	26.94	42	21	12	22	22	22	22	12	9	30	34	73.14					
75.14	140-150	15000	21.28	21.28	26.94	42	21	12	22	22	22	22	12	9	30	34	75.14					
77.14	140-150	15000	21.28	21.28	26.94	42	21	12	22	22	22	22	12	9	30	34	77.14					
79.14	150-160	16000	21.28	21.28	26.94	42	21	12	22	22	22	22	12	9	30	34	79.14					
81.14	150-160	16000	21.28	21.28	26.94	42	21	12	22	22	22	22	12	9	30	34	81.14					
83.14	160-170	17000	21.28	21.28	26.94	42	21	12	22	22	22	22	12	9	30	34	83.14					
85.14	160-170	17000	21.28	21.28	26.94	42	21	12	22	22	22	22	12	9	30	34	85.14					
87.14	170-180	18000	21.28	21.28	26.94	42	21	12	22	22	22	22	12	9	30	34	87.14					
89.14	170-180	18000	21.28	21.28	26.94	42	21	12	22	22	22	22	12	9	30	34	89.14					
91.14	180-190	19000	21.28	21.28	26.94	42	21	12	22	22	22	22	12	9	30	34	91.14					
93.14	180-190	19000	21.28	21.28	26.94	42	21	12	22	22	22	22	12	9	30	34	93.14					
95.14	190-200	20000	21.28	21.28	26.94	42	21	12	22	22	22	22	12	9	30	34	95.14					
97.14	190-200	20000	21.28	21.28	26.94	42	21	12	22	22	22	22	12	9	30	34	97.14					

## APPENDIX D – Metal Grate Sound Profile

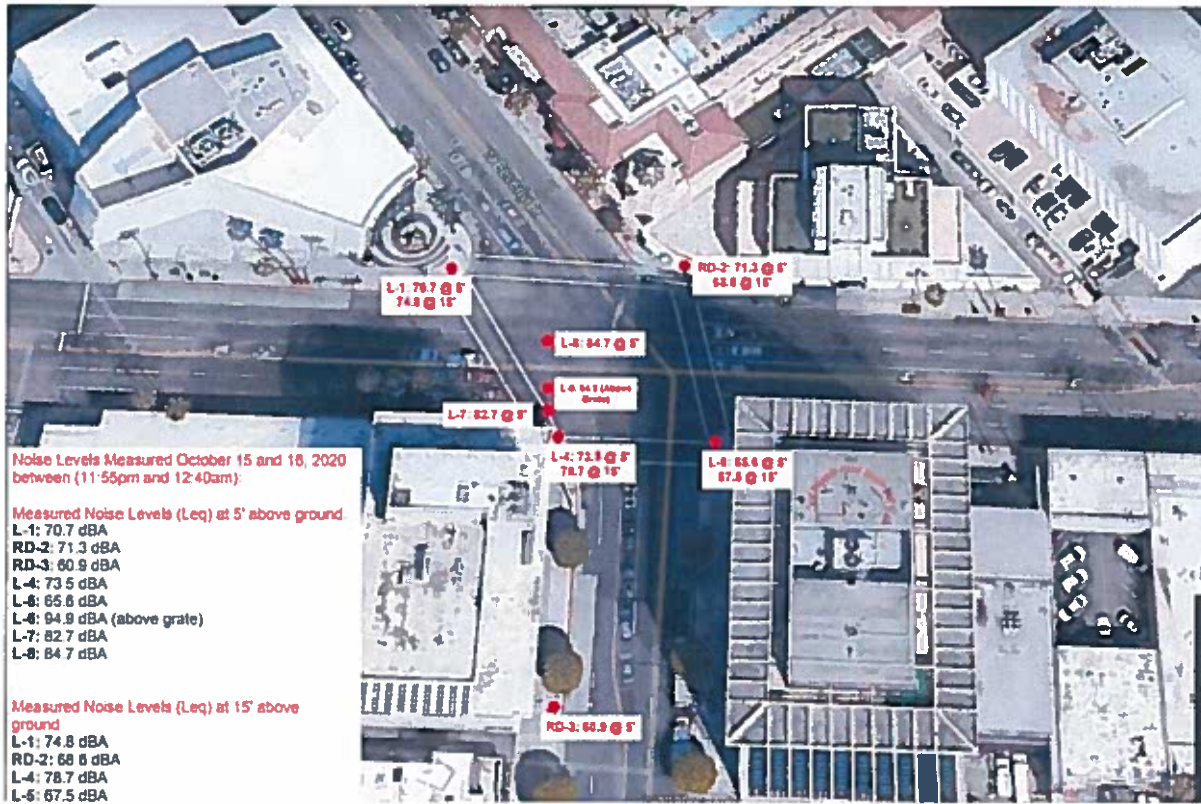

Calculated Sound Power Level



Receiver Point	Leq
L-1 (5ft)	70.7
RD-2	68
RD-2 (15 ft)	70
RD-3	61.8
L-1 (15 ft)	74.8
L-4 (5ft)	75.3
L-4 (15 ft)	77.2
L-5 (5ft)	67.3
L-5 (15 ft)	69.6
L-6 (5ft)	100
L-7 (5ft)	81.5
L-8 (5ft)	84

Ventilation Intake Silencer- Product Data

VIBRO-ACOUSTICS®

Noise Control | Vibration Isolation | Restraint Systems

tel: 416-291-7371 1-800-565-8401 web: www.vibro-acoustics.com  
 fax: 416-291-8049 1-888-811-2264 email: info@vibro-acoustics.com

CIRCULAR DISSIPATIVE

CD

File No.: 03A-003 Date: 17 Sep 2013  
 Supersedes: 03A-002 Date: 19 Aug 2013

QTY: 2		TAG: SA-1,SA-2			
Submitted for: Approval	Dwg #: 26170-1	Rev #: 0	Drawn by:	Rev. Date: 01 Oct, 2020	Rev. by:
Project <b>Metro PLE2</b>		Customer <b>CSDA Design Group</b>		Customer P.O. No.	
V-A Project No. <b>1142142</b>	V-A Project Manager		Consultant		

Performance for Model CD-UHV-F1

Airflow CFM	Velocity (L/s)	Velocity FPM	Velocity (m/s)	Pressure Drop		Pressure Drop w/ System Effects*		Dynamic Insertion Loss (dB)							
				in. w.g.	(Pa)	in. w.g.	(Pa)	63 Hz	125 Hz	250 Hz	500 Hz	1 KHz	2 KHz	4 KHz	8 KHz
51000	24,102	4658	21	0.03	8	0.04	11	9	11	14	13	9	7	5	4

Silencer performance data has been obtained from tests conducted in a laboratory facility NVLAP accredited for the ASTM E477-06a test standard.

\* Duct configuration must be known for at least 5 duct diameters upstream and downstream of the silencer to determine pressure drop with system effects

Dimensions and Weights

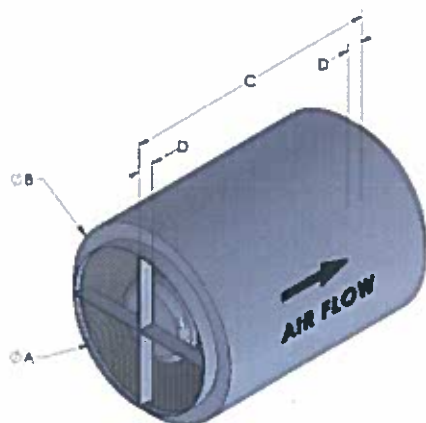

Silencer Size (in/mm)				Total Wt
A	B	C	D	(lb/kg)
48	64	84	2	1,053

Construction

Casing	12 Ga (2.75 mm) Galvanized
	Continuously Welded
Perforated Liner	22 Ga (0.85 mm) Galvanized
Media Fill	Acoustic Grade Glass Fiber
Media Protection	None
End connections	2" (51 mm) slip connection
Accessories	None

Ratings

Pressure rating	8 in H <sub>2</sub> O (1822 Pa)	
Combustion rating (ASTM E84 or CAN/ULC S.102)	Flamespread classification	< 25
	Smoke development rating	< 50

Notes

- Customer to confirm all dimensions.
- Silencer construction meets applicable requirements of SMACNA Duct Construction Standards, ASHRAE 62.1, UL181, ASTM C1071, NFPA 90A and NFPA 90B.
- Lubricants and sealants used during manufacturing may contain silicone.
- Gauges and thicknesses are based on SMACNA standard nominal and will vary within prescribed tolerances.
- Electronic document links:  
[Dissipative Straight Silencers](#)  
[Installation Instructions / Operation & Maintenance](#)  
[NVLAP Accreditation](#)

Calculated Sound Power Level after using Noise Silencer for the Vent intake

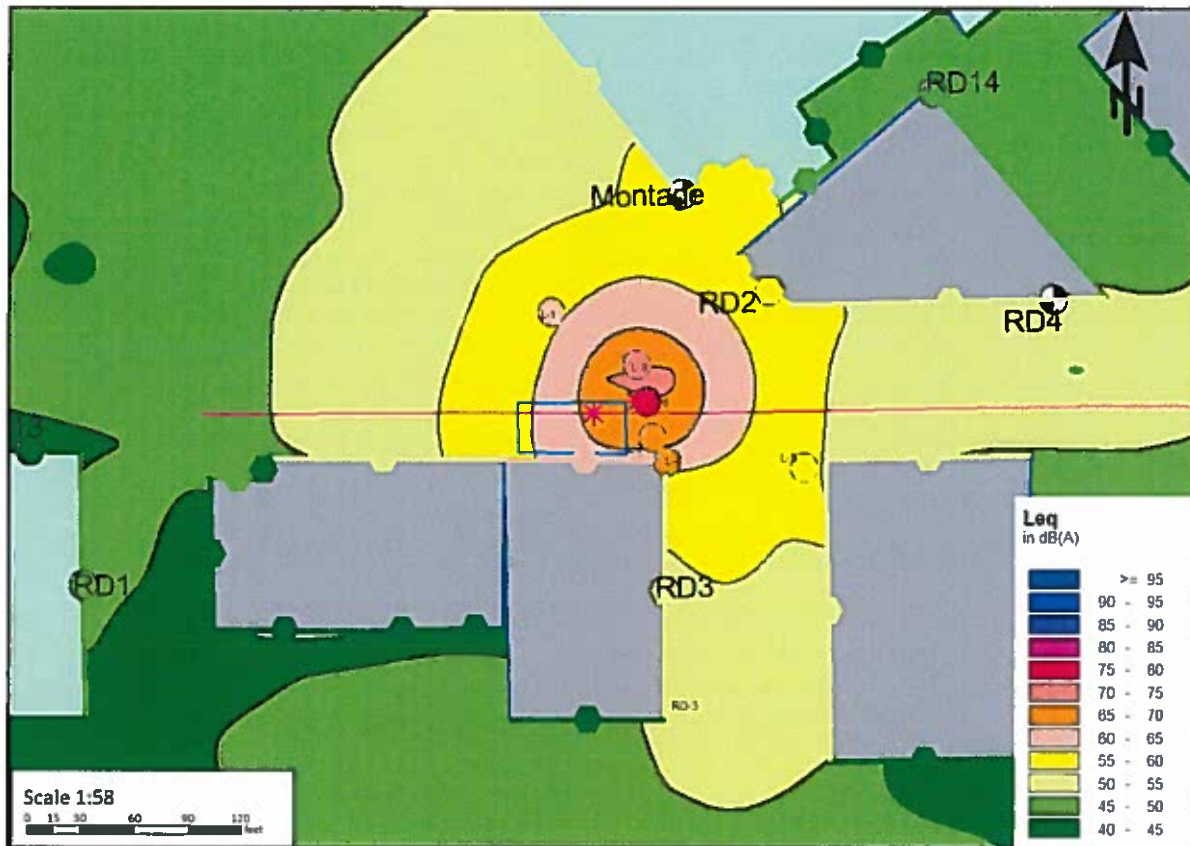

Receiver Point	Leq
L-1 (5ft)	59
RD-2	56
RD-2 (15 ft)	58
RD-3	50
L-1 (15 ft)	61
L-4 (5ft)	63.3
L-4 (15 ft)	66
L-5 (5ft)	56
L-5 (15 ft)	58
L-6 (5ft)	79
L-7 (5ft)	69
L-8 (5ft)	72.2

## **APPENDIX E - RESULTS**

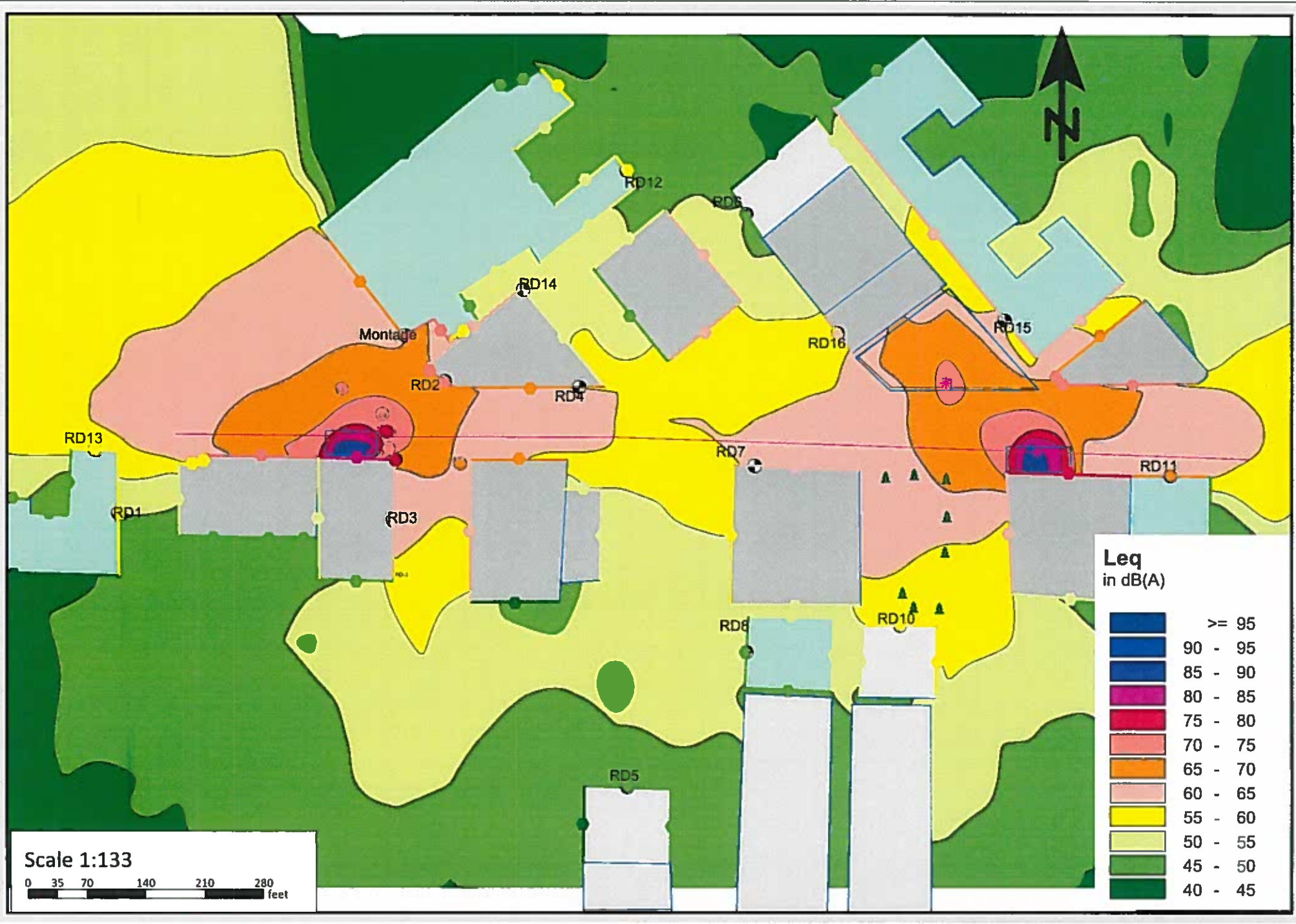

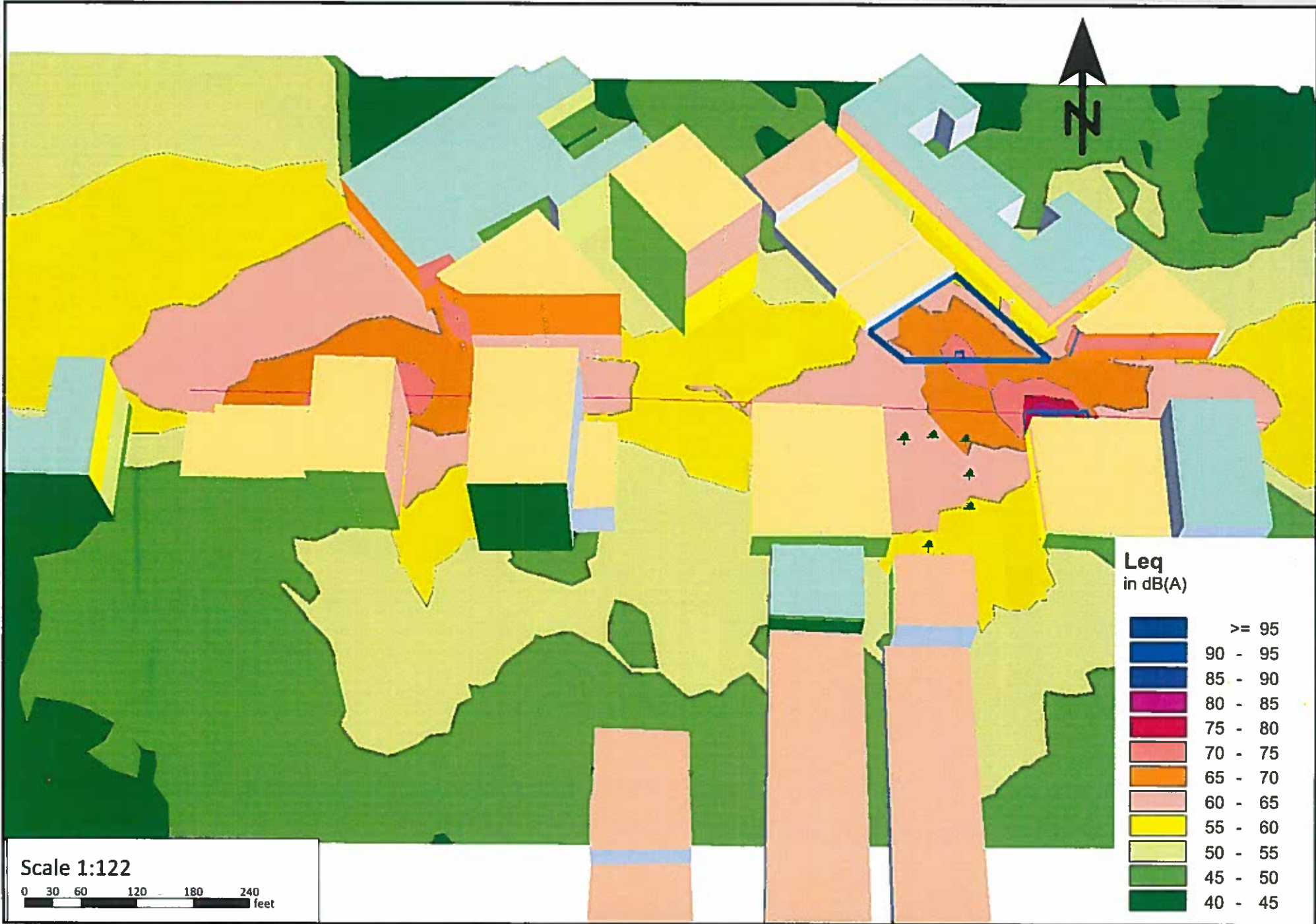



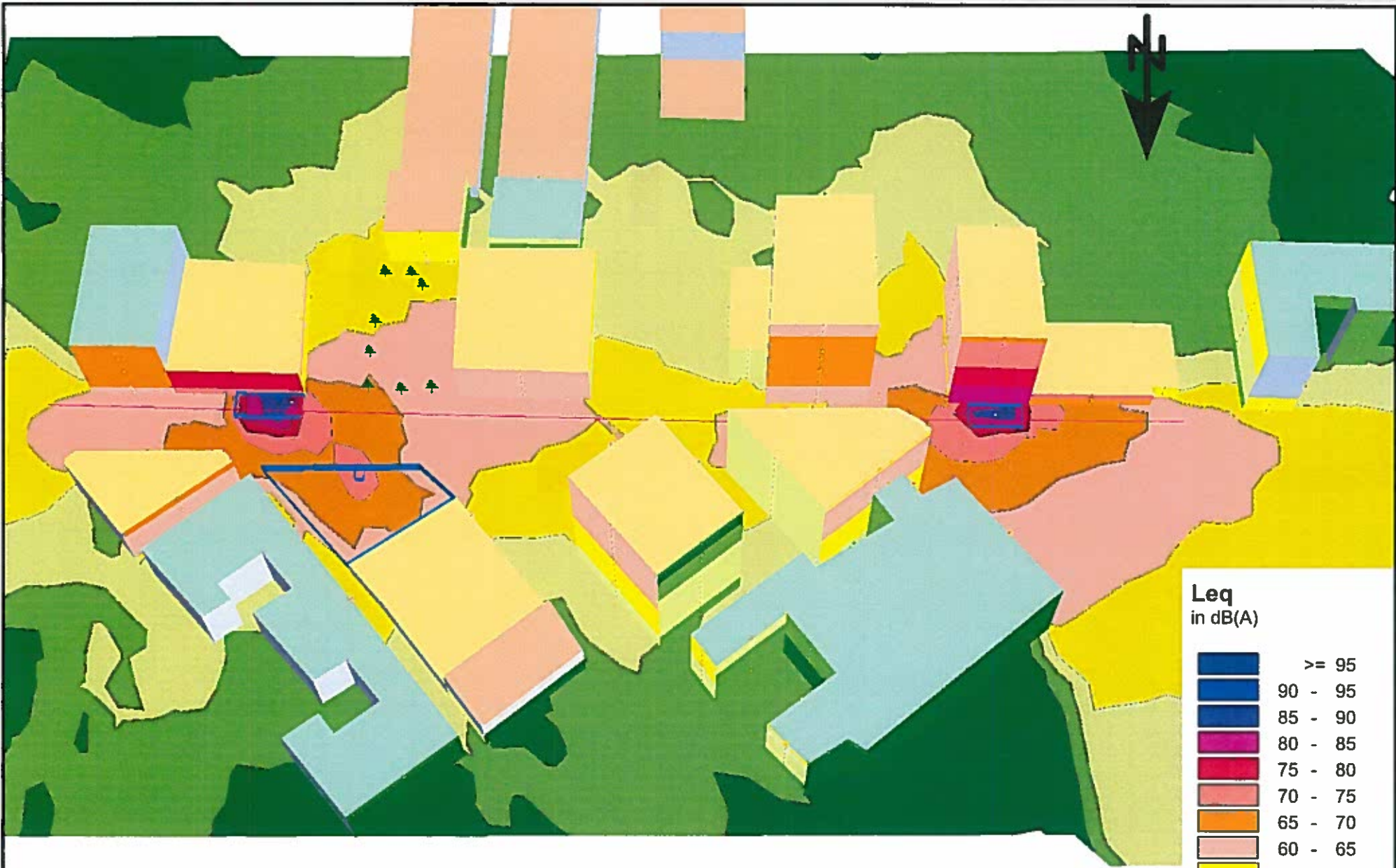

**Leq**  
in dB(A)

Dark Blue	>= 95
Blue	90 - 95
Dark Purple	85 - 90
Purple	80 - 85
Red	75 - 80
Light Red	70 - 75
Orange	65 - 70
Light Orange	60 - 65
Yellow	55 - 60
Light Green	50 - 55
Green	45 - 50
Dark Green	40 - 45

Scale 1:122



## RD 1 Weekday

Time	Leq15 Threshold	Predicted	Exceedance (Yes/No)
12:00:00 AM	71	50	No
12:15:00 AM	70	50	No
12:30:00 AM	69	50	No
12:45:00 AM	69	50	No
1:00:00 AM	72	50	No
1:15:00 AM	68	50	No
1:30:00 AM	73	50	No
1:45:00 AM	70	50	No
2:00:00 AM	73	50	No
2:15:00 AM	67	50	No
2:30:00 AM	69	50	No
2:45:00 AM	68	50	No
3:00:00 AM	69	50	No
3:15:00 AM	70	50	No
3:30:00 AM	67	50	No
3:45:00 AM	67	50	No
4:00:00 AM	66	50	No
4:15:00 AM	70	50	No
4:30:00 AM	70	50	No
4:45:00 AM	71	50	No
5:00:00 AM	74	50	No
5:15:00 AM	74	50	No
5:30:00 AM	73	50	No
5:45:00 AM	72	50	No
6:00:00 AM	74	50	No
6:15:00 AM	76	50	No
6:30:00 AM	76	50	No
6:45:00 AM	76	50	No
7:00:00 AM	76	50	No
7:15:00 AM	75	50	No
7:30:00 AM	78	50	No
7:45:00 AM	76	50	No
8:00:00 AM	78	50	No
8:15:00 AM	77	50	No
8:30:00 AM	76	50	No
8:45:00 AM	76	50	No
9:00:00 AM	77	50	No
9:15:00 AM	86	50	No
9:30:00 AM	76	50	No
9:45:00 AM	76	50	No
10:00:00 AM	75	50	No
10:15:00 AM	76	50	No
10:30:00 AM	75	50	No
10:45:00 AM	74	50	No
11:00:00 AM	75	50	No
11:15:00 AM	75	50	No
11:30:00 AM	76	50	No
11:45:00 AM	75	50	No
12:00:00 PM	74	50	No
12:15:00 PM	75	50	No
12:30:00 PM	75	50	No
12:45:00 PM	75	50	No
1:00:00 PM	75	50	No
1:15:00 PM	77	50	No
1:30:00 PM	74	50	No
1:45:00 PM	83	50	No
2:00:00 PM	75	50	No
2:15:00 PM	74	50	No
2:30:00 PM	74	50	No

RD 1 Weekday			
Time	Leq15 Threshold	Predicted	Exceedance (Yes/No)
2:45:00 PM	74	50	No
3:00:00 PM	74	50	No
3:15:00 PM	75	50	No
3:30:00 PM	75	50	No
3:45:00 PM	74	50	No
4:00:00 PM	74	50	No
4:15:00 PM	75	50	No
4:30:00 PM	77	50	No
4:45:00 PM	75	50	No
5:00:00 PM	75	50	No
5:15:00 PM	81	50	No
5:30:00 PM	80	50	No
5:45:00 PM	80	50	No
6:00:00 PM	81	50	No
6:15:00 PM	74	50	No
6:30:00 PM	75	50	No
6:45:00 PM	81	50	No
7:00:00 PM	75	50	No
7:15:00 PM	77	50	No
7:30:00 PM	74	50	No
7:45:00 PM	74	50	No
8:00:00 PM	83	50	No
8:15:00 PM	75	50	No
8:30:00 PM	74	50	No
8:45:00 PM	75	50	No
9:00:00 PM	74	50	No
9:15:00 PM	75	50	No
9:30:00 PM	73	50	No
9:45:00 PM	75	50	No
10:00:00 PM	73	50	No
10:15:00 PM	73	50	No
10:30:00 PM	75	50	No
10:45:00 PM	72	50	No
11:00:00 PM	72	50	No
11:15:00 PM	73	50	No
11:30:00 PM	71	50	No
11:45:00 PM	71	50	No

RD1 Weekend			
Time	Leq15 Threshold	Predicted	Exceedance (Yes/No)
12:00:00 AM	71	50	No
12:15:00 AM	70	50	No
12:30:00 AM	71	50	No
12:45:00 AM	70	50	No
1:00:00 AM	69	50	No
1:15:00 AM	70	50	No
1:30:00 AM	69	50	No
1:45:00 AM	68	50	No
2:00:00 AM	68	50	No
2:15:00 AM	72	50	No
2:30:00 AM	68	50	No
2:45:00 AM	69	50	No
3:00:00 AM	76	50	No
3:15:00 AM	67	50	No
3:30:00 AM	76	50	No
3:45:00 AM	66	50	No
4:00:00 AM	65	50	No
4:15:00 AM	69	50	No
4:30:00 AM	67	50	No
4:45:00 AM	70	50	No
5:00:00 AM	66	50	No
5:15:00 AM	67	50	No
5:30:00 AM	66	50	No
5:45:00 AM	68	50	No
6:00:00 AM	70	50	No
6:15:00 AM	70	50	No
6:30:00 AM	70	50	No
6:45:00 AM	70	50	No
7:00:00 AM	70	50	No
7:15:00 AM	70	50	No
7:30:00 AM	71	50	No
7:45:00 AM	71	50	No
8:00:00 AM	71	50	No
8:15:00 AM	72	50	No
8:30:00 AM	71	50	No
8:45:00 AM	71	50	No
9:00:00 AM	72	50	No
9:15:00 AM	72	50	No
9:30:00 AM	72	50	No
9:45:00 AM	73	50	No
10:00:00 AM	72	50	No
10:15:00 AM	72	50	No
10:30:00 AM	74	50	No
10:45:00 AM	73	50	No
11:00:00 AM	74	50	No
11:15:00 AM	74	50	No
11:30:00 AM	73	50	No
11:45:00 AM	84	50	No
12:00:00 PM	73	50	No
12:15:00 PM	74	50	No
12:30:00 PM	73	50	No
12:45:00 PM	73	50	No
1:00:00 PM	73	50	No
1:15:00 PM	72	50	No
1:30:00 PM	74	50	No
1:45:00 PM	73	50	No
2:00:00 PM	72	50	No

RDI Weekend			
Time	Leq15 Threshold	Predicted	Exceedance (Yes/No)
2:15:00 PM	73	50	No
2:30:00 PM	73	50	No
2:45:00 PM	72	50	No
3:00:00 PM	82	50	No
3:15:00 PM	72	50	No
3:30:00 PM	72	50	No
3:45:00 PM	76	50	No
4:00:00 PM	78	50	No
4:15:00 PM	74	50	No
4:30:00 PM	73	50	No
4:45:00 PM	77	50	No
5:00:00 PM	73	50	No
5:15:00 PM	72	50	No
5:30:00 PM	72	50	No
5:45:00 PM	74	50	No
6:00:00 PM	73	50	No
6:15:00 PM	73	50	No
6:30:00 PM	76	50	No
6:45:00 PM	72	50	No
7:00:00 PM	74	50	No
7:15:00 PM	74	50	No
7:30:00 PM	74	50	No
7:45:00 PM	75	50	No
8:00:00 PM	74	50	No
8:15:00 PM	75	50	No
8:30:00 PM	76	50	No
8:45:00 PM	73	50	No
9:00:00 PM	75	50	No
9:15:00 PM	74	50	No
9:30:00 PM	75	50	No
9:45:00 PM	75	50	No
10:00:00 PM	72	50	No
10:15:00 PM	74	50	No
10:30:00 PM	73	50	No
10:45:00 PM	73	50	No
11:00:00 PM	72	50	No
11:15:00 PM	80	50	No
11:30:00 PM	75	50	No
11:45:00 PM	72	50	No

RD2 Weekdays			
Time	Leq15 Threshold	Predicted	Exceedance (Yes/No)
12:00:00 AM	74	65	No
12:15:00 AM	75	65	No
12:30:00 AM	73	65	No
12:45:00 AM	83	65	No
1:00:00 AM	73	65	No
1:15:00 AM	71	65	No
1:30:00 AM	79	65	No
1:45:00 AM	80	65	No
2:00:00 AM	71	65	No
2:15:00 AM	73	65	No
2:30:00 AM	71	65	No
2:45:00 AM	70	65	No
3:00:00 AM	76	65	No
3:15:00 AM	73	65	No
3:30:00 AM	69	65	No
3:45:00 AM	71	65	No
4:00:00 AM	71	65	No
4:15:00 AM	71	65	No
4:30:00 AM	75	65	No
4:45:00 AM	74	65	No
5:00:00 AM	75	65	No
5:15:00 AM	75	65	No
5:30:00 AM	76	65	No
5:45:00 AM	77	65	No
6:00:00 AM	77	65	No
6:15:00 AM	79	65	No
6:30:00 AM	83	65	No
6:45:00 AM	80	65	No
7:00:00 AM	83	65	No
7:15:00 AM	80	65	No
7:30:00 AM	81	65	No
7:45:00 AM	82	65	No
8:00:00 AM	82	65	No
8:15:00 AM	80	65	No
8:30:00 AM	80	65	No
8:45:00 AM	81	65	No
9:00:00 AM	80	65	No
9:15:00 AM	81	65	No
9:30:00 AM	80	65	No
9:45:00 AM	80	65	No
10:00:00 AM	82	65	No
10:15:00 AM	80	65	No
10:30:00 AM	80	65	No
10:45:00 AM	80	65	No
11:00:00 AM	80	65	No
11:15:00 AM	79	65	No
11:30:00 AM	78	65	No
11:45:00 AM	79	65	No
12:00:00 PM	84	65	No
12:15:00 PM	81	65	No
12:30:00 PM	80	65	No
12:45:00 PM	79	65	No
1:00:00 PM	81	65	No
1:15:00 PM	80	65	No
1:30:00 PM	79	65	No
1:45:00 PM	80	65	No

RD2 Weekdays			
Time	Leq15 Threshold	Predicted	Exceedance (Yes/No)
2:00:00 PM	81	65	No
2:15:00 PM	79	65	No
2:30:00 PM	80	65	No
2:45:00 PM	80	65	No
3:00:00 PM	79	65	No
3:15:00 PM	79	65	No
3:30:00 PM	80	65	No
3:45:00 PM	80	65	No
4:00:00 PM	80	65	No
4:15:00 PM	78	65	No
4:30:00 PM	77	65	No
4:45:00 PM	79	65	No
5:00:00 PM	80	65	No
5:15:00 PM	81	65	No
5:30:00 PM	80	65	No
5:45:00 PM	80	65	No
6:00:00 PM	79	65	No
6:15:00 PM	78	65	No
6:30:00 PM	79	65	No
6:45:00 PM	79	65	No
7:00:00 PM	80	65	No
7:15:00 PM	78	65	No
7:30:00 PM	78	65	No
7:45:00 PM	78	65	No
8:00:00 PM	78	65	No
8:15:00 PM	79	65	No
8:30:00 PM	77	65	No
8:45:00 PM	80	65	No
9:00:00 PM	77	65	No
9:15:00 PM	78	65	No
9:30:00 PM	78	65	No
9:45:00 PM	77	65	No
10:00:00 PM	83	65	No
10:15:00 PM	78	65	No
10:30:00 PM	80	65	No
10:45:00 PM	76	65	No
11:00:00 PM	80	65	No
11:15:00 PM	78	65	No
11:30:00 PM	74	65	No
11:45:00 PM	74	65	No

RD2 Weekends			
Time	Leq15 Threshold	Predicted	Exceedance (Yes/No)
12:00:00 AM	81	65	No
12:15:00 AM	73	65	No
12:30:00 AM	74	65	No
12:45:00 AM	72	65	No
1:00:00 AM	71	65	No
1:15:00 AM	72	65	No
1:30:00 AM	72	65	No
1:45:00 AM	71	65	No
2:00:00 AM	71	65	No
2:15:00 AM	76	65	No
2:30:00 AM	74	65	No
2:45:00 AM	80	65	No
3:00:00 AM	75	65	No
3:15:00 AM	70	65	No
3:30:00 AM	70	65	No
3:45:00 AM	69	65	No
4:00:00 AM	67	65	No
4:15:00 AM	69	65	No
4:30:00 AM	69	65	No
4:45:00 AM	72	65	No
5:00:00 AM	67	65	No
5:15:00 AM	66	65	No
5:30:00 AM	71	65	No
5:45:00 AM	72	65	No
6:00:00 AM	70	65	No
6:15:00 AM	70	65	No
6:30:00 AM	71	65	No
6:45:00 AM	73	65	No
7:00:00 AM	81	65	No
7:15:00 AM	73	65	No
7:30:00 AM	74	65	No
7:45:00 AM	74	65	No
8:00:00 AM	75	65	No
8:15:00 AM	76	65	No
8:30:00 AM	76	65	No
8:45:00 AM	75	65	No
9:00:00 AM	75	65	No
9:15:00 AM	76	65	No
9:30:00 AM	76	65	No
9:45:00 AM	77	65	No
10:00:00 AM	76	65	No
10:15:00 AM	80	65	No
10:30:00 AM	77	65	No
10:45:00 AM	76	65	No
11:00:00 AM	77	65	No
11:15:00 AM	77	65	No
11:30:00 AM	78	65	No
11:45:00 AM	80	65	No
12:00:00 PM	78	65	No
12:15:00 PM	77	65	No
12:30:00 PM	79	65	No
12:45:00 PM	79	65	No
1:00:00 PM	78	65	No
1:15:00 PM	77	65	No
1:30:00 PM	76	65	No
1:45:00 PM	77	65	No



RD2 Weekends			
Time	Leq15 Threshold	Predicted	Exceedance (Yes/No)
2:00:00 PM	77	65	No
2:15:00 PM	84	65	No
2:30:00 PM	78	65	No
2:45:00 PM	79	65	No
3:00:00 PM	85	65	No
3:15:00 PM	78	65	No
3:30:00 PM	77	65	No
3:45:00 PM	77	65	No
4:00:00 PM	81	65	No
4:15:00 PM	78	65	No
4:30:00 PM	79	65	No
4:45:00 PM	79	65	No
5:00:00 PM	79	65	No
5:15:00 PM	77	65	No
5:30:00 PM	77	65	No
5:45:00 PM	81	65	No
6:00:00 PM	77	65	No
6:15:00 PM	78	65	No
6:30:00 PM	76	65	No
6:45:00 PM	76	65	No
7:00:00 PM	78	65	No
7:15:00 PM	78	65	No
7:30:00 PM	84	65	No
7:45:00 PM	79	65	No
8:00:00 PM	80	65	No
8:15:00 PM	77	65	No
8:30:00 PM	80	65	No
8:45:00 PM	77	65	No
9:00:00 PM	78	65	No
9:15:00 PM	78	65	No
9:30:00 PM	83	65	No
9:45:00 PM	79	65	No
10:00:00 PM	77	65	No
10:15:00 PM	79	65	No
10:30:00 PM	77	65	No
10:45:00 PM	76	65	No
11:00:00 PM	76	65	No
11:15:00 PM	76	65	No
11:30:00 PM	76	65	No
11:45:00 PM	76	65	No

<b>RD2 Elevated Receiver</b>			
<b>Time</b>	<b>Leq15 Threshold</b>	<b>Predicted</b>	<b>Exceedance (Yes/No)</b>
12:00:00 AM	74	67	No
12:15:00 AM	74	67	No
12:30:00 AM	73	67	No
12:45:00 AM	83	67	No
1:00:00 AM	73	67	No
1:15:00 AM	71	67	No
1:30:00 AM	79	67	No
1:45:00 AM	80	67	No
2:00:00 AM	70	67	No
2:15:00 AM	72	67	No
2:30:00 AM	71	67	No
2:45:00 AM	70	67	No
3:00:00 AM	76	67	No
3:15:00 AM	72	67	No
3:30:00 AM	68	67	No
3:45:00 AM	70	67	No
4:00:00 AM	71	67	No
4:15:00 AM	71	67	No
4:30:00 AM	75	67	No
4:45:00 AM	74	67	No
5:00:00 AM	75	67	No
5:15:00 AM	75	67	No
5:30:00 AM	76	67	No
5:45:00 AM	77	67	No
6:00:00 AM	77	67	No
6:15:00 AM	79	67	No
6:30:00 AM	83	67	No
6:45:00 AM	80	67	No
7:00:00 AM	83	67	No
7:15:00 AM	80	67	No
7:30:00 AM	81	67	No
7:45:00 AM	81	67	No
8:00:00 AM	81	67	No
8:15:00 AM	80	67	No
8:30:00 AM	80	67	No
8:45:00 AM	80	67	No
9:00:00 AM	80	67	No
9:15:00 AM	80	67	No
9:30:00 AM	80	67	No
9:45:00 AM	80	67	No
10:00:00 AM	82	67	No
10:15:00 AM	79	67	No
10:30:00 AM	79	67	No
10:45:00 AM	79	67	No
11:00:00 AM	80	67	No
11:15:00 AM	79	67	No
11:30:00 AM	78	67	No
11:45:00 AM	79	67	No
12:00:00 PM	84	67	No
12:15:00 PM	81	67	No
12:30:00 PM	80	67	No
12:45:00 PM	78	67	No
1:00:00 PM	80	67	No
1:15:00 PM	80	67	No
1:30:00 PM	79	67	No
1:45:00 PM	79	67	No

**RD2 Elevated Receiver**

Time	Leq15 Threshold	Predicted	Exceedance (Yes/No)
2:00:00 PM	81	67	No
2:15:00 PM	79	67	No
2:30:00 PM	80	67	No
2:45:00 PM	80	67	No
3:00:00 PM	79	67	No
3:15:00 PM	79	67	No
3:30:00 PM	79	67	No
3:45:00 PM	79	67	No
4:00:00 PM	80	67	No
4:15:00 PM	78	67	No
4:30:00 PM	77	67	No
4:45:00 PM	79	67	No
5:00:00 PM	80	67	No
5:15:00 PM	81	67	No
5:30:00 PM	80	67	No
5:45:00 PM	79	67	No
6:00:00 PM	79	67	No
6:15:00 PM	78	67	No
6:30:00 PM	79	67	No
6:45:00 PM	79	67	No
7:00:00 PM	79	67	No
7:15:00 PM	78	67	No
7:30:00 PM	78	67	No
7:45:00 PM	78	67	No
8:00:00 PM	78	67	No
8:15:00 PM	79	67	No
8:30:00 PM	77	67	No
8:45:00 PM	79	67	No
9:00:00 PM	77	67	No
9:15:00 PM	78	67	No
9:30:00 PM	77	67	No
9:45:00 PM	77	67	No
10:00:00 PM	82	67	No
10:15:00 PM	78	67	No
10:30:00 PM	80	67	No
10:45:00 PM	75	67	No
11:00:00 PM	80	67	No
11:15:00 PM	77	67	No
11:30:00 PM	74	67	No
11:45:00 PM	74	67	No

RD3 Weekdays			
Time	Leq15 Threshold	Predicted	Exceedance (Yes/No)
12:00:00 AM	75	59	No
12:15:00 AM	72	59	No
12:30:00 AM	73	59	No
12:45:00 AM	70	59	No
1:00:00 AM	72	59	No
1:15:00 AM	70	59	No
1:30:00 AM	75	59	No
1:45:00 AM	70	59	No
2:00:00 AM	73	59	No
2:15:00 AM	70	59	No
2:30:00 AM	76	59	No
2:45:00 AM	79	59	No
3:00:00 AM	77	59	No
3:15:00 AM	67	59	No
3:30:00 AM	72	59	No
3:45:00 AM	66	59	No
4:00:00 AM	66	59	No
4:15:00 AM	67	59	No
4:30:00 AM	69	59	No
4:45:00 AM	72	59	No
5:00:00 AM	74	59	No
5:15:00 AM	75	59	No
5:30:00 AM	77	59	No
5:45:00 AM	77	59	No
6:00:00 AM	78	59	No
6:15:00 AM	79	59	No
6:30:00 AM	79	59	No
6:45:00 AM	78	59	No
7:00:00 AM	79	59	No
7:15:00 AM	79	59	No
7:30:00 AM	79	59	No
7:45:00 AM	78	59	No
8:00:00 AM	78	59	No
8:15:00 AM	79	59	No
8:30:00 AM	78	59	No
8:45:00 AM	77	59	No
9:00:00 AM	80	59	No
9:15:00 AM	80	59	No
9:30:00 AM	78	59	No
9:45:00 AM	77	59	No
10:00:00 AM	78	59	No
10:15:00 AM	77	59	No
10:30:00 AM	77	59	No
10:45:00 AM	77	59	No
11:00:00 AM	78	59	No
11:15:00 AM	77	59	No
11:30:00 AM	85	59	No
11:45:00 AM	77	59	No
12:00:00 PM	78	59	No
12:15:00 PM	78	59	No
12:30:00 PM	78	59	No
12:45:00 PM	78	59	No
1:00:00 PM	78	59	No
1:15:00 PM	77	59	No
1:30:00 PM	79	59	No
1:45:00 PM	79	59	No
2:00:00 PM	78	59	No

RD3 Weekdays			
Time	Leq15 Threshold	Predicted	Exceedance (Yes/No)
2:15:00 PM	78	59	No
2:30:00 PM	78	59	No
2:45:00 PM	79	59	No
3:00:00 PM	78	59	No
3:15:00 PM	78	59	No
3:30:00 PM	80	59	No
3:45:00 PM	78	59	No
4:00:00 PM	78	59	No
4:15:00 PM	79	59	No
4:30:00 PM	79	59	No
4:45:00 PM	79	59	No
5:00:00 PM	80	59	No
5:15:00 PM	80	59	No
5:30:00 PM	81	59	No
5:45:00 PM	79	59	No
6:00:00 PM	81	59	No
6:15:00 PM	79	59	No
6:30:00 PM	78	59	No
6:45:00 PM	82	59	No
7:00:00 PM	78	59	No
7:15:00 PM	80	59	No
7:30:00 PM	80	59	No
7:45:00 PM	79	59	No
8:00:00 PM	82	59	No
8:15:00 PM	80	59	No
8:30:00 PM	79	59	No
8:45:00 PM	78	59	No
9:00:00 PM	81	59	No
9:15:00 PM	76	59	No
9:30:00 PM	78	59	No
9:45:00 PM	77	59	No
10:00:00 PM	76	59	No
10:15:00 PM	78	59	No
10:30:00 PM	79	59	No
10:45:00 PM	75	59	No
11:00:00 PM	76	59	No
11:15:00 PM	75	59	No
11:30:00 PM	74	59	No
11:45:00 PM	75	59	No

RD3 Weekend			
Time	Leq15 Threshold	Predicted	Exceedance (Yes/No)
12:00:00 AM	75	59	No
12:15:00 AM	74	59	No
12:30:00 AM	74	59	No
12:45:00 AM	72	59	No
1:00:00 AM	71	59	No
1:15:00 AM	67	59	No
1:30:00 AM	67	59	No
1:45:00 AM	67	59	No
2:00:00 AM	72	59	No
2:15:00 AM	70	59	No
2:30:00 AM	71	59	No
2:45:00 AM	75	59	No
3:00:00 AM	72	59	No
3:15:00 AM	61	59	No
3:30:00 AM	66	59	No
3:45:00 AM	64	59	No
4:00:00 AM	64	59	No
4:15:00 AM	60	59	No
4:30:00 AM	60	59	No
4:45:00 AM	63	59	No
5:00:00 AM	65	59	No
5:15:00 AM	65	59	No
5:30:00 AM	69	59	No
5:45:00 AM	69	59	No
6:00:00 AM	70	59	No
6:15:00 AM	71	59	No
6:30:00 AM	72	59	No
6:45:00 AM	71	59	No
7:00:00 AM	72	59	No
7:15:00 AM	71	59	No
7:30:00 AM	72	59	No
7:45:00 AM	70	59	No
8:00:00 AM	72	59	No
8:15:00 AM	72	59	No
8:30:00 AM	73	59	No
8:45:00 AM	73	59	No
9:00:00 AM	72	59	No
9:15:00 AM	72	59	No
9:30:00 AM	73	59	No
9:45:00 AM	73	59	No
10:00:00 AM	72	59	No
10:15:00 AM	74	59	No
10:30:00 AM	76	59	No
10:45:00 AM	73	59	No
11:00:00 AM	72	59	No
11:15:00 AM	78	59	No
11:30:00 AM	77	59	No
11:45:00 AM	78	59	No
12:00:00 PM	78	59	No
12:15:00 PM	77	59	No
12:30:00 PM	80	59	No
12:45:00 PM	78	59	No
1:00:00 PM	80	59	No
1:15:00 PM	76	59	No
1:30:00 PM	76	59	No
1:45:00 PM	76	59	No
2:00:00 PM	76	59	No

RD3 Weekend			
Time	Leq15 Threshold	Predicted	Exceedance (Yes/No)
2:15:00 PM	77	59	No
2:30:00 PM	78	59	No
2:45:00 PM	78	59	No
3:00:00 PM	78	59	No
3:15:00 PM	79	59	No
3:30:00 PM	77	59	No
3:45:00 PM	79	59	No
4:00:00 PM	81	59	No
4:15:00 PM	78	59	No
4:30:00 PM	78	59	No
4:45:00 PM	80	59	No
5:00:00 PM	81	59	No
5:15:00 PM	81	59	No
5:30:00 PM	79	59	No
5:45:00 PM	80	59	No
6:00:00 PM	79	59	No
6:15:00 PM	78	59	No
6:30:00 PM	79	59	No
6:45:00 PM	77	59	No
7:00:00 PM	78	59	No
7:15:00 PM	80	59	No
7:30:00 PM	79	59	No
7:45:00 PM	81	59	No
8:00:00 PM	78	59	No
8:15:00 PM	77	59	No
8:30:00 PM	83	59	No
8:45:00 PM	77	59	No
9:00:00 PM	77	59	No
9:15:00 PM	77	59	No
9:30:00 PM	80	59	No
9:45:00 PM	81	59	No
10:00:00 PM	77	59	No
10:15:00 PM	78	59	No
10:30:00 PM	76	59	No
10:45:00 PM	77	59	No
11:00:00 PM	78	59	No
11:15:00 PM	76	59	No
11:30:00 PM	76	59	No
11:45:00 PM	77	59	No

RD4 Weekdays			
Time	Leq15 Threshold	Predicted	Exceedance (Yes/No)
12:00:00 AM	79	59	No
12:15:00 AM	78	59	No
12:30:00 AM	75	59	No
12:45:00 AM	87	59	No
1:00:00 AM	75	59	No
1:15:00 AM	73	59	No
1:30:00 AM	85	59	No
1:45:00 AM	83	59	No
2:00:00 AM	73	59	No
2:15:00 AM	74	59	No
2:30:00 AM	74	59	No
2:45:00 AM	74	59	No
3:00:00 AM	78	59	No
3:15:00 AM	75	59	No
3:30:00 AM	72	59	No
3:45:00 AM	72	59	No
4:00:00 AM	73	59	No
4:15:00 AM	74	59	No
4:30:00 AM	76	59	No
4:45:00 AM	78	59	No
5:00:00 AM	77	59	No
5:15:00 AM	80	59	No
5:30:00 AM	80	59	No
5:45:00 AM	81	59	No
6:00:00 AM	81	59	No
6:15:00 AM	81	59	No
6:30:00 AM	82	59	No
6:45:00 AM	83	59	No
7:00:00 AM	82	59	No
7:15:00 AM	83	59	No
7:30:00 AM	84	59	No
7:45:00 AM	84	59	No
8:00:00 AM	83	59	No
8:15:00 AM	83	59	No
8:30:00 AM	83	59	No
8:45:00 AM	84	59	No
9:00:00 AM	83	59	No
9:15:00 AM	84	59	No
9:30:00 AM	83	59	No
9:45:00 AM	82	59	No
10:00:00 AM	86	59	No
10:15:00 AM	83	59	No
10:30:00 AM	82	59	No
10:45:00 AM	83	59	No
11:00:00 AM	81	59	No
11:15:00 AM	81	59	No
11:30:00 AM	82	59	No
11:45:00 AM	82	59	No
12:00:00 PM	85	59	No
12:15:00 PM	82	59	No
12:30:00 PM	81	59	No
12:45:00 PM	81	59	No
1:00:00 PM	83	59	No
1:15:00 PM	83	59	No
1:30:00 PM	82	59	No
1:45:00 PM	82	59	No
2:00:00 PM	83	59	No



RD4 Weekdays			
Time	Leq15 Threshold	Predicted	Exceedance (Yes/No)
2:15:00 PM	81	59	No
2:30:00 PM	83	59	No
2:45:00 PM	84	59	No
3:00:00 PM	82	59	No
3:15:00 PM	81	59	No
3:30:00 PM	83	59	No
3:45:00 PM	82	59	No
4:00:00 PM	83	59	No
4:15:00 PM	81	59	No
4:30:00 PM	81	59	No
4:45:00 PM	81	59	No
5:00:00 PM	82	59	No
5:15:00 PM	82	59	No
5:30:00 PM	81	59	No
5:45:00 PM	82	59	No
6:00:00 PM	83	59	No
6:15:00 PM	79	59	No
6:30:00 PM	80	59	No
6:45:00 PM	79	59	No
7:00:00 PM	81	59	No
7:15:00 PM	81	59	No
7:30:00 PM	80	59	No
7:45:00 PM	80	59	No
8:00:00 PM	80	59	No
8:15:00 PM	80	59	No
8:30:00 PM	80	59	No
8:45:00 PM	79	59	No
9:00:00 PM	79	59	No
9:15:00 PM	80	59	No
9:30:00 PM	82	59	No
9:45:00 PM	78	59	No
10:00:00 PM	88	59	No
10:15:00 PM	79	59	No
10:30:00 PM	84	59	No
10:45:00 PM	78	59	No
11:00:00 PM	78	59	No
11:15:00 PM	78	59	No
11:30:00 PM	77	59	No
11:45:00 PM	77	59	No

<b>RD4 Weekends</b>			
<b>Time</b>	<b>Leq15 Threshold</b>	<b>Predicted</b>	<b>Exceedance (Yes/No)</b>
12:00:00 AM	76	59	No
12:15:00 AM	77	59	No
12:30:00 AM	76	59	No
12:45:00 AM	75	59	No
1:00:00 AM	74	59	No
1:15:00 AM	74	59	No
1:30:00 AM	75	59	No
1:45:00 AM	73	59	No
2:00:00 AM	73	59	No
2:15:00 AM	76	59	No
2:30:00 AM	73	59	No
2:45:00 AM	74	59	No
3:00:00 AM	75	59	No
3:15:00 AM	75	59	No
3:30:00 AM	74	59	No
3:45:00 AM	71	59	No
4:00:00 AM	70	59	No
4:15:00 AM	70	59	No
4:30:00 AM	71	59	No
4:45:00 AM	74	59	No
5:00:00 AM	69	59	No
5:15:00 AM	69	59	No
5:30:00 AM	72	59	No
5:45:00 AM	72	59	No
6:00:00 AM	71	59	No
6:15:00 AM	73	59	No
6:30:00 AM	74	59	No
6:45:00 AM	75	59	No
7:00:00 AM	76	59	No
7:15:00 AM	76	59	No
7:30:00 AM	76	59	No
7:45:00 AM	76	59	No
8:00:00 AM	77	59	No
8:15:00 AM	77	59	No
8:30:00 AM	77	59	No
8:45:00 AM	77	59	No
9:00:00 AM	78	59	No
9:15:00 AM	77	59	No
9:30:00 AM	77	59	No
9:45:00 AM	79	59	No
10:00:00 AM	78	59	No
10:15:00 AM	78	59	No
10:30:00 AM	78	59	No
10:45:00 AM	78	59	No
11:00:00 AM	78	59	No
11:15:00 AM	78	59	No
11:30:00 AM	78	59	No
11:45:00 AM	83	59	No
12:00:00 PM	78	59	No
12:15:00 PM	78	59	No
12:30:00 PM	79	59	No
12:45:00 PM	79	59	No
1:00:00 PM	79	59	No
1:15:00 PM	78	59	No
1:30:00 PM	78	59	No
1:45:00 PM	78	59	No
2:00:00 PM	78	59	No

RD4 Weekends			
Time	Leq15 Threshold	Predicted	Exceedance (Yes/No)
2:15:00 PM	79	59	No
2:30:00 PM	78	59	No
2:45:00 PM	79	59	No
3:00:00 PM	81	59	No
3:15:00 PM	78	59	No
3:30:00 PM	78	59	No
3:45:00 PM	77	59	No
4:00:00 PM	83	59	No
4:15:00 PM	77	59	No
4:30:00 PM	79	59	No
4:45:00 PM	81	59	No
5:00:00 PM	78	59	No
5:15:00 PM	77	59	No
5:30:00 PM	78	59	No
5:45:00 PM	79	59	No
6:00:00 PM	77	59	No
6:15:00 PM	78	59	No
6:30:00 PM	77	59	No
6:45:00 PM	78	59	No
7:00:00 PM	79	59	No
7:15:00 PM	80	59	No
7:30:00 PM	80	59	No
7:45:00 PM	79	59	No
8:00:00 PM	79	59	No
8:15:00 PM	79	59	No
8:30:00 PM	79	59	No
8:45:00 PM	79	59	No
9:00:00 PM	79	59	No
9:15:00 PM	79	59	No
9:30:00 PM	78	59	No
9:45:00 PM	79	59	No
10:00:00 PM	78	59	No
10:15:00 PM	78	59	No
10:30:00 PM	78	59	No
10:45:00 PM	78	59	No
11:00:00 PM	77	59	No
11:15:00 PM	78	59	No
11:30:00 PM	78	59	No
11:45:00 PM	80	59	No

RD5 Weekdays			
Time	Leq15 Threshold	Predicted	Exceedance (Yes/No)
12:00:00 AM	61	47	No
12:15:00 AM	64	47	No
12:30:00 AM	60	47	No
12:45:00 AM	62	47	No
1:00:00 AM	60	47	No
1:15:00 AM	58	47	No
1:30:00 AM	58	47	No
1:45:00 AM	60	47	No
2:00:00 AM	58	47	No
2:15:00 AM	58	47	No
2:30:00 AM	59	47	No
2:45:00 AM	59	47	No
3:00:00 AM	57	47	No
3:15:00 AM	55	47	No
3:30:00 AM	55	47	No
3:45:00 AM	55	47	No
4:00:00 AM	55	47	No
4:15:00 AM	55	47	No
4:30:00 AM	56	47	No
4:45:00 AM	56	47	No
5:00:00 AM	56	47	No
5:15:00 AM	60	47	No
5:30:00 AM	59	47	No
5:45:00 AM	62	47	No
6:00:00 AM	60	47	No
6:15:00 AM	60	47	No
6:30:00 AM	63	47	No
6:45:00 AM	64	47	No
7:00:00 AM	62	47	No
7:15:00 AM	63	47	No
7:30:00 AM	63	47	No
7:45:00 AM	63	47	No
8:00:00 AM	66	47	No
8:15:00 AM	65	47	No
8:30:00 AM	69	47	No
8:45:00 AM	66	47	No
9:00:00 AM	69	47	No
9:15:00 AM	73	47	No
9:30:00 AM	67	47	No
9:45:00 AM	66	47	No
10:00:00 AM	68	47	No
10:15:00 AM	68	47	No
10:30:00 AM	66	47	No
10:45:00 AM	68	47	No
11:00:00 AM	66	47	No
11:15:00 AM	70	47	No
11:30:00 AM	68	47	No
11:45:00 AM	66	47	No
12:00:00 PM	66	47	No
12:15:00 PM	66	47	No
12:30:00 PM	68	47	No
12:45:00 PM	66	47	No
1:00:00 PM	66	47	No
1:15:00 PM	68	47	No
1:30:00 PM	68	47	No
1:45:00 PM	73	47	No
2:00:00 PM	67	47	No

RDS Weekdays			
Time	Leq15 Threshold	Predicted	Exceedance (Yes/No)
2:15:00 PM	67	47	No
2:30:00 PM	66	47	No
2:45:00 PM	67	47	No
3:00:00 PM	67	47	No
3:15:00 PM	66	47	No
3:30:00 PM	68	47	No
3:45:00 PM	68	47	No
4:00:00 PM	73	47	No
4:15:00 PM	72	47	No
4:30:00 PM	74	47	No
4:45:00 PM	74	47	No
5:00:00 PM	77	47	No
5:15:00 PM	70	47	No
5:30:00 PM	71	47	No
5:45:00 PM	67	47	No
6:00:00 PM	68	47	No
6:15:00 PM	68	47	No
6:30:00 PM	82	47	No
6:45:00 PM	72	47	No
7:00:00 PM	65	47	No
7:15:00 PM	65	47	No
7:30:00 PM	67	47	No
7:45:00 PM	65	47	No
8:00:00 PM	72	47	No
8:15:00 PM	67	47	No
8:30:00 PM	67	47	No
8:45:00 PM	66	47	No
9:00:00 PM	64	47	No
9:15:00 PM	64	47	No
9:30:00 PM	63	47	No
9:45:00 PM	64	47	No
10:00:00 PM	63	47	No
10:15:00 PM	64	47	No
10:30:00 PM	65	47	No
10:45:00 PM	62	47	No
11:00:00 PM	62	47	No
11:15:00 PM	62	47	No
11:30:00 PM	62	47	No
11:45:00 PM	63	47	No

RDS Weekends			
Time	Leq15 Threshold	Predicted	Exceedance (Yes/No)
12:00:00 AM	62	47	No
12:15:00 AM	68	47	No
12:30:00 AM	63	47	No
12:45:00 AM	60	47	No
1:00:00 AM	60	47	No
1:15:00 AM	60	47	No
1:30:00 AM	60	47	No
1:45:00 AM	59	47	No
2:00:00 AM	59	47	No
2:15:00 AM	62	47	No
2:30:00 AM	59	47	No
2:45:00 AM	63	47	No
3:00:00 AM	60	47	No
3:15:00 AM	62	47	No
3:30:00 AM	59	47	No
3:45:00 AM	59	47	No
4:00:00 AM	58	47	No
4:15:00 AM	56	47	No
4:30:00 AM	57	47	No
4:45:00 AM	58	47	No
5:00:00 AM	57	47	No
5:15:00 AM	54	47	No
5:30:00 AM	56	47	No
5:45:00 AM	57	47	No
6:00:00 AM	55	47	No
6:15:00 AM	57	47	No
6:30:00 AM	59	47	No
6:45:00 AM	61	47	No
7:00:00 AM	61	47	No
7:15:00 AM	61	47	No
7:30:00 AM	61	47	No
7:45:00 AM	62	47	No
8:00:00 AM	63	47	No
8:15:00 AM	64	47	No
8:30:00 AM	63	47	No
8:45:00 AM	62	47	No
9:00:00 AM	62	47	No
9:15:00 AM	62	47	No
9:30:00 AM	62	47	No
9:45:00 AM	64	47	No
10:00:00 AM	65	47	No
10:15:00 AM	64	47	No
10:30:00 AM	64	47	No
10:45:00 AM	64	47	No
11:00:00 AM	64	47	No
11:15:00 AM	64	47	No
11:30:00 AM	64	47	No
11:45:00 AM	69	47	No
12:00:00 PM	63	47	No
12:15:00 PM	66	47	No
12:30:00 PM	65	47	No
12:45:00 PM	66	47	No
1:00:00 PM	64	47	No
1:15:00 PM	64	47	No
1:30:00 PM	65	47	No
1:45:00 PM	64	47	No
2:00:00 PM	65	47	No

RDS Weekends			
Time	Leq15 Threshold	Predicted	Exceedance (Yes/No)
2:15:00 PM	64	47	No
2:30:00 PM	64	47	No
2:45:00 PM	65	47	No
3:00:00 PM	72	47	No
3:15:00 PM	64	47	No
3:30:00 PM	66	47	No
3:45:00 PM	64	47	No
4:00:00 PM	72	47	No
4:15:00 PM	64	47	No
4:30:00 PM	68	47	No
4:45:00 PM	70	47	No
5:00:00 PM	65	47	No
5:15:00 PM	65	47	No
5:30:00 PM	65	47	No
5:45:00 PM	65	47	No
6:00:00 PM	64	47	No
6:15:00 PM	64	47	No
6:30:00 PM	65	47	No
6:45:00 PM	65	47	No
7:00:00 PM	67	47	No
7:15:00 PM	65	47	No
7:30:00 PM	67	47	No
7:45:00 PM	65	47	No
8:00:00 PM	66	47	No
8:15:00 PM	65	47	No
8:30:00 PM	66	47	No
8:45:00 PM	64	47	No
9:00:00 PM	65	47	No
9:15:00 PM	65	47	No
9:30:00 PM	65	47	No
9:45:00 PM	64	47	No
10:00:00 PM	64	47	No
10:15:00 PM	65	47	No
10:30:00 PM	64	47	No
10:45:00 PM	63	47	No
11:00:00 PM	62	47	No
11:15:00 PM	63	47	No
11:30:00 PM	62	47	No
11:45:00 PM	64	47	No

RD6 Weekdays			
Time	Leq15 Threshold	Predicted	Exceedance (Yes/No)
12:00:00 AM	71	49	No
12:15:00 AM	72	49	No
12:30:00 AM	69	49	No
12:45:00 AM	71	49	No
1:00:00 AM	69	49	No
1:15:00 AM	66	49	No
1:30:00 AM	66	49	No
1:45:00 AM	66	49	No
2:00:00 AM	72	49	No
2:15:00 AM	69	49	No
2:30:00 AM	71	49	No
2:45:00 AM	62	49	No
3:00:00 AM	71	49	No
3:15:00 AM	64	49	No
3:30:00 AM	62	49	No
3:45:00 AM	70	49	No
4:00:00 AM	64	49	No
4:15:00 AM	68	49	No
4:30:00 AM	67	49	No
4:45:00 AM	68	49	No
5:00:00 AM	71	49	No
5:15:00 AM	72	49	No
5:30:00 AM	73	49	No
5:45:00 AM	71	49	No
6:00:00 AM	74	49	No
6:15:00 AM	76	49	No
6:30:00 AM	78	49	No
6:45:00 AM	75	49	No
7:00:00 AM	76	49	No
7:15:00 AM	81	49	No
7:30:00 AM	76	49	No
7:45:00 AM	76	49	No
8:00:00 AM	77	49	No
8:15:00 AM	75	49	No
8:30:00 AM	75	49	No
8:45:00 AM	80	49	No
9:00:00 AM	76	49	No
9:15:00 AM	79	49	No
9:30:00 AM	76	49	No
9:45:00 AM	75	49	No
10:00:00 AM	77	49	No
10:15:00 AM	75	49	No
10:30:00 AM	75	49	No
10:45:00 AM	75	49	No
11:00:00 AM	77	49	No
11:15:00 AM	76	49	No
11:30:00 AM	75	49	No
11:45:00 AM	76	49	No
12:00:00 PM	76	49	No
12:15:00 PM	76	49	No
12:30:00 PM	76	49	No
12:45:00 PM	77	49	No
1:00:00 PM	76	49	No
1:15:00 PM	76	49	No
1:30:00 PM	74	49	No
1:45:00 PM	77	49	No
2:00:00 PM	74	49	No



RD6 Weekdays			
Time	Leq15 Threshold	Predicted	Exceedance (Yes/No)
2:15:00 PM	75	49	No
2:30:00 PM	74	49	No
2:45:00 PM	75	49	No
3:00:00 PM	78	49	No
3:15:00 PM	75	49	No
3:30:00 PM	75	49	No
3:45:00 PM	75	49	No
4:00:00 PM	77	49	No
4:15:00 PM	76	49	No
4:30:00 PM	74	49	No
4:45:00 PM	76	49	No
5:00:00 PM	74	49	No
5:15:00 PM	76	49	No
5:30:00 PM	76	49	No
5:45:00 PM	77	49	No
6:00:00 PM	78	49	No
6:15:00 PM	76	49	No
6:30:00 PM	83	49	No
6:45:00 PM	78	49	No
7:00:00 PM	75	49	No
7:15:00 PM	75	49	No
7:30:00 PM	76	49	No
7:45:00 PM	77	49	No
8:00:00 PM	85	49	No
8:15:00 PM	75	49	No
8:30:00 PM	76	49	No
8:45:00 PM	76	49	No
9:00:00 PM	75	49	No
9:15:00 PM	76	49	No
9:30:00 PM	75	49	No
9:45:00 PM	80	49	No
10:00:00 PM	74	49	No
10:15:00 PM	75	49	No
10:30:00 PM	76	49	No
10:45:00 PM	74	49	No
11:00:00 PM	71	49	No
11:15:00 PM	73	49	No
11:30:00 PM	70	49	No
11:45:00 PM	76	49	No

RD6 Weekends			
Time	Leq15 Threshold	Predicted	Exceedance (Yes/No)
12:00:00 AM	70	49	No
12:15:00 AM	73	49	No
12:30:00 AM	74	49	No
12:45:00 AM	71	49	No
1:00:00 AM	68	49	No
1:15:00 AM	69	49	No
1:30:00 AM	77	49	No
1:45:00 AM	67	49	No
2:00:00 AM	74	49	No
2:15:00 AM	80	49	No
2:30:00 AM	72	49	No
2:45:00 AM	73	49	No
3:00:00 AM	78	49	No
3:15:00 AM	78	49	No
3:30:00 AM	73	49	No
3:45:00 AM	69	49	No
4:00:00 AM	75	49	No
4:15:00 AM	72	49	No
4:30:00 AM	72	49	No
4:45:00 AM	72	49	No
5:00:00 AM	62	49	No
5:15:00 AM	64	49	No
5:30:00 AM	66	49	No
5:45:00 AM	68	49	No
6:00:00 AM	64	49	No
6:15:00 AM	74	49	No
6:30:00 AM	68	49	No
6:45:00 AM	69	49	No
7:00:00 AM	69	49	No
7:15:00 AM	69	49	No
7:30:00 AM	71	49	No
7:45:00 AM	69	49	No
8:00:00 AM	73	49	No
8:15:00 AM	70	49	No
8:30:00 AM	73	49	No
8:45:00 AM	71	49	No
9:00:00 AM	71	49	No
9:15:00 AM	71	49	No
9:30:00 AM	72	49	No
9:45:00 AM	73	49	No
10:00:00 AM	73	49	No
10:15:00 AM	75	49	No
10:30:00 AM	74	49	No
10:45:00 AM	75	49	No
11:00:00 AM	71	49	No
11:15:00 AM	71	49	No
11:30:00 AM	72	49	No
11:45:00 AM	74	49	No
12:00:00 PM	74	49	No
12:15:00 PM	72	49	No
12:30:00 PM	73	49	No
12:45:00 PM	75	49	No
1:00:00 PM	74	49	No
1:15:00 PM	74	49	No
1:30:00 PM	74	49	No
1:45:00 PM	75	49	No
2:00:00 PM	75	49	No

RD6 Weekends			
Time	Leq15 Threshold	Predicted	Exceedance (Yes/No)
2:15:00 PM	74	49	No
2:30:00 PM	73	49	No
2:45:00 PM	72	49	No
3:00:00 PM	75	49	No
3:15:00 PM	74	49	No
3:30:00 PM	73	49	No
3:45:00 PM	72	49	No
4:00:00 PM	75	49	No
4:15:00 PM	76	49	No
4:30:00 PM	73	49	No
4:45:00 PM	74	49	No
5:00:00 PM	73	49	No
5:15:00 PM	74	49	No
5:30:00 PM	74	49	No
5:45:00 PM	73	49	No
6:00:00 PM	72	49	No
6:15:00 PM	73	49	No
6:30:00 PM	72	49	No
6:45:00 PM	75	49	No
7:00:00 PM	74	49	No
7:15:00 PM	74	49	No
7:30:00 PM	75	49	No
7:45:00 PM	74	49	No
8:00:00 PM	74	49	No
8:15:00 PM	75	49	No
8:30:00 PM	75	49	No
8:45:00 PM	76	49	No
9:00:00 PM	76	49	No
9:15:00 PM	76	49	No
9:30:00 PM	75	49	No
9:45:00 PM	75	49	No
10:00:00 PM	77	49	No
10:15:00 PM	76	49	No
10:30:00 PM	73	49	No
10:45:00 PM	75	49	No
11:00:00 PM	73	49	No
11:15:00 PM	75	49	No
11:30:00 PM	72	49	No
11:45:00 PM	73	49	No

RD7 Weekdays			
Time	Leq15 Threshold	Predicted	Exceedance (Yes/No)
12:00:00 AM	76	59	No
12:15:00 AM	80	59	No
12:30:00 AM	75	59	No
12:45:00 AM	75	59	No
1:00:00 AM	76	59	No
1:15:00 AM	73	59	No
1:30:00 AM	71	59	No
1:45:00 AM	79	59	No
2:00:00 AM	73	59	No
2:15:00 AM	73	59	No
2:30:00 AM	72	59	No
2:45:00 AM	69	59	No
3:00:00 AM	73	59	No
3:15:00 AM	69	59	No
3:30:00 AM	68	59	No
3:45:00 AM	73	59	No
4:00:00 AM	70	59	No
4:15:00 AM	72	59	No
4:30:00 AM	73	59	No
4:45:00 AM	74	59	No
5:00:00 AM	75	59	No
5:15:00 AM	75	59	No
5:30:00 AM	77	59	No
5:45:00 AM	77	59	No
6:00:00 AM	79	59	No
6:15:00 AM	79	59	No
6:30:00 AM	82	59	No
6:45:00 AM	83	59	No
7:00:00 AM	81	59	No
7:15:00 AM	83	59	No
7:30:00 AM	82	59	No
7:45:00 AM	82	59	No
8:00:00 AM	83	59	No
8:15:00 AM	83	59	No
8:30:00 AM	81	59	No
8:45:00 AM	81	59	No
9:00:00 AM	82	59	No
9:15:00 AM	92	59	No
9:30:00 AM	81	59	No
9:45:00 AM	81	59	No
10:00:00 AM	82	59	No
10:15:00 AM	82	59	No
10:30:00 AM	81	59	No
10:45:00 AM	81	59	No
11:00:00 AM	81	59	No
11:15:00 AM	81	59	No
11:30:00 AM	80	59	No
11:45:00 AM	81	59	No
12:00:00 PM	80	59	No
12:15:00 PM	82	59	No
12:30:00 PM	85	59	No
12:45:00 PM	80	59	No
1:00:00 PM	80	59	No
1:15:00 PM	81	59	No
1:30:00 PM	82	59	No
1:45:00 PM	89	59	No
2:00:00 PM	80	59	No

RD7 Weekdays			
Time	Leq15 Threshold	Predicted	Exceedance (Yes/No)
2:15:00 PM	80	59	No
2:30:00 PM	80	59	No
2:45:00 PM	81	59	No
3:00:00 PM	82	59	No
3:15:00 PM	81	59	No
3:30:00 PM	81	59	No
3:45:00 PM	81	59	No
4:00:00 PM	81	59	No
4:15:00 PM	81	59	No
4:30:00 PM	81	59	No
4:45:00 PM	82	59	No
5:00:00 PM	80	59	No
5:15:00 PM	85	59	No
5:30:00 PM	85	59	No
5:45:00 PM	86	59	No
6:00:00 PM	84	59	No
6:15:00 PM	81	59	No
6:30:00 PM	90	59	No
6:45:00 PM	88	59	No
7:00:00 PM	80	59	No
7:15:00 PM	81	59	No
7:30:00 PM	82	59	No
7:45:00 PM	81	59	No
8:00:00 PM	89	59	No
8:15:00 PM	80	59	No
8:30:00 PM	80	59	No
8:45:00 PM	80	59	No
9:00:00 PM	80	59	No
9:15:00 PM	80	59	No
9:30:00 PM	80	59	No
9:45:00 PM	81	59	No
10:00:00 PM	78	59	No
10:15:00 PM	79	59	No
10:30:00 PM	81	59	No
10:45:00 PM	77	59	No
11:00:00 PM	78	59	No
11:15:00 PM	79	59	No
11:30:00 PM	76	59	No
11:45:00 PM	78	59	No

RD7 Weekends			
Time	Leq15 Threshold	Predicted	Exceedance (Yes/No)
12:00:00 AM	76	59	No
12:15:00 AM	82	59	No
12:30:00 AM	77	59	No
12:45:00 AM	75	59	No
1:00:00 AM	75	59	No
1:15:00 AM	75	59	No
1:30:00 AM	74	59	No
1:45:00 AM	73	59	No
2:00:00 AM	73	59	No
2:15:00 AM	80	59	No
2:30:00 AM	72	59	No
2:45:00 AM	73	59	No
3:00:00 AM	75	59	No
3:15:00 AM	77	59	No
3:30:00 AM	75	59	No
3:45:00 AM	71	59	No
4:00:00 AM	72	59	No
4:15:00 AM	69	59	No
4:30:00 AM	71	59	No
4:45:00 AM	72	59	No
5:00:00 AM	69	59	No
5:15:00 AM	68	59	No
5:30:00 AM	71	59	No
5:45:00 AM	71	59	No
6:00:00 AM	70	59	No
6:15:00 AM	73	59	No
6:30:00 AM	74	59	No
6:45:00 AM	74	59	No
7:00:00 AM	75	59	No
7:15:00 AM	75	59	No
7:30:00 AM	76	59	No
7:45:00 AM	76	59	No
8:00:00 AM	77	59	No
8:15:00 AM	77	59	No
8:30:00 AM	77	59	No
8:45:00 AM	77	59	No
9:00:00 AM	78	59	No
9:15:00 AM	77	59	No
9:30:00 AM	77	59	No
9:45:00 AM	79	59	No
10:00:00 AM	77	59	No
10:15:00 AM	78	59	No
10:30:00 AM	78	59	No
10:45:00 AM	78	59	No
11:00:00 AM	78	59	No
11:15:00 AM	78	59	No
11:30:00 AM	78	59	No
11:45:00 AM	85	59	No
12:00:00 PM	78	59	No
12:15:00 PM	78	59	No
12:30:00 PM	80	59	No
12:45:00 PM	79	59	No
1:00:00 PM	79	59	No
1:15:00 PM	79	59	No
1:30:00 PM	79	59	No
1:45:00 PM	79	59	No
2:00:00 PM	79	59	No

RD7 Weekends			
Time	Leq15 Threshold	Predicted	Exceedance (Yes/No)
2:15:00 PM	78	59	No
2:30:00 PM	79	59	No
2:45:00 PM	78	59	No
3:00:00 PM	88	59	No
3:15:00 PM	78	59	No
3:30:00 PM	78	59	No
3:45:00 PM	78	59	No
4:00:00 PM	82	59	No
4:15:00 PM	78	59	No
4:30:00 PM	79	59	No
4:45:00 PM	82	59	No
5:00:00 PM	79	59	No
5:15:00 PM	78	59	No
5:30:00 PM	78	59	No
5:45:00 PM	79	59	No
6:00:00 PM	78	59	No
6:15:00 PM	78	59	No
6:30:00 PM	78	59	No
6:45:00 PM	77	59	No
7:00:00 PM	80	59	No
7:15:00 PM	80	59	No
7:30:00 PM	79	59	No
7:45:00 PM	80	59	No
8:00:00 PM	80	59	No
8:15:00 PM	80	59	No
8:30:00 PM	82	59	No
8:45:00 PM	79	59	No
9:00:00 PM	80	59	No
9:15:00 PM	79	59	No
9:30:00 PM	78	59	No
9:45:00 PM	80	59	No
10:00:00 PM	78	59	No
10:15:00 PM	79	59	No
10:30:00 PM	79	59	No
10:45:00 PM	79	59	No
11:00:00 PM	77	59	No
11:15:00 PM	77	59	No
11:30:00 PM	77	59	No
11:45:00 PM	82	59	No

RD8 Weekdays			
Time	Leq15 Threshold	Predicted	Exceedance (Yes/No)
12:00:00 AM	66	49	No
12:15:00 AM	70	49	No
12:30:00 AM	65	49	No
12:45:00 AM	65	49	No
1:00:00 AM	65	49	No
1:15:00 AM	62	49	No
1:30:00 AM	62	49	No
1:45:00 AM	64	49	No
2:00:00 AM	61	49	No
2:15:00 AM	62	49	No
2:30:00 AM	62	49	No
2:45:00 AM	61	49	No
3:00:00 AM	61	49	No
3:15:00 AM	60	49	No
3:30:00 AM	59	49	No
3:45:00 AM	62	49	No
4:00:00 AM	61	49	No
4:15:00 AM	62	49	No
4:30:00 AM	65	49	No
4:45:00 AM	64	49	No
5:00:00 AM	66	49	No
5:15:00 AM	66	49	No
5:30:00 AM	67	49	No
5:45:00 AM	67	49	No
6:00:00 AM	68	49	No
6:15:00 AM	69	49	No
6:30:00 AM	72	49	No
6:45:00 AM	73	49	No
7:00:00 AM	70	49	No
7:15:00 AM	80	49	No
7:30:00 AM	71	49	No
7:45:00 AM	72	49	No
8:00:00 AM	73	49	No
8:15:00 AM	73	49	No
8:30:00 AM	72	49	No
8:45:00 AM	72	49	No
9:00:00 AM	73	49	No
9:15:00 AM	79	49	No
9:30:00 AM	73	49	No
9:45:00 AM	71	49	No
10:00:00 AM	73	49	No
10:15:00 AM	74	49	No
10:30:00 AM	72	49	No
10:45:00 AM	71	49	No
11:00:00 AM	72	49	No
11:15:00 AM	73	49	No
11:30:00 AM	75	49	No
11:45:00 AM	72	49	No
12:00:00 PM	72	49	No
12:15:00 PM	73	49	No
12:30:00 PM	73	49	No
12:45:00 PM	73	49	No
1:00:00 PM	72	49	No
1:15:00 PM	72	49	No
1:30:00 PM	75	49	No
1:45:00 PM	78	49	No
2:00:00 PM	71	49	No



RD8 Weekdays			
Time	Leq15 Threshold	Predicted	Exceedance (Yes/No)
2:15:00 PM	71	49	No
2:30:00 PM	71	49	No
2:45:00 PM	71	49	No
3:00:00 PM	72	49	No
3:15:00 PM	73	49	No
3:30:00 PM	72	49	No
3:45:00 PM	71	49	No
4:00:00 PM	72	49	No
4:15:00 PM	71	49	No
4:30:00 PM	71	49	No
4:45:00 PM	72	49	No
5:00:00 PM	73	49	No
5:15:00 PM	74	49	No
5:30:00 PM	77	49	No
5:45:00 PM	74	49	No
6:00:00 PM	74	49	No
6:15:00 PM	71	49	No
6:30:00 PM	88	49	No
6:45:00 PM	78	49	No
7:00:00 PM	71	49	No
7:15:00 PM	71	49	No
7:30:00 PM	73	49	No
7:45:00 PM	71	49	No
8:00:00 PM	78	49	No
8:15:00 PM	70	49	No
8:30:00 PM	69	49	No
8:45:00 PM	70	49	No
9:00:00 PM	69	49	No
9:15:00 PM	69	49	No
9:30:00 PM	69	49	No
9:45:00 PM	70	49	No
10:00:00 PM	68	49	No
10:15:00 PM	68	49	No
10:30:00 PM	70	49	No
10:45:00 PM	67	49	No
11:00:00 PM	67	49	No
11:15:00 PM	69	49	No
11:30:00 PM	67	49	No
11:45:00 PM	69	49	No

RD8 Elevated Receiver			
Time	Leq15 Threshold	Predicted	Exceedance (Yes/No)
12:00:00 AM	66	47	No
12:15:00 AM	70	47	No
12:30:00 AM	66	47	No
12:45:00 AM	65	47	No
1:00:00 AM	65	47	No
1:15:00 AM	62	47	No
1:30:00 AM	62	47	No
1:45:00 AM	64	47	No
2:00:00 AM	62	47	No
2:15:00 AM	62	47	No
2:30:00 AM	62	47	No
2:45:00 AM	61	47	No
3:00:00 AM	61	47	No
3:15:00 AM	60	47	No
3:30:00 AM	59	47	No
3:45:00 AM	62	47	No
4:00:00 AM	62	47	No
4:15:00 AM	62	47	No
4:30:00 AM	65	47	No
4:45:00 AM	64	47	No
5:00:00 AM	66	47	No
5:15:00 AM	66	47	No
5:30:00 AM	67	47	No
5:45:00 AM	67	47	No
6:00:00 AM	68	47	No
6:15:00 AM	69	47	No
6:30:00 AM	72	47	No
6:45:00 AM	73	47	No
7:00:00 AM	71	47	No
7:15:00 AM	80	47	No
7:30:00 AM	71	47	No
7:45:00 AM	72	47	No
8:00:00 AM	73	47	No
8:15:00 AM	73	47	No
8:30:00 AM	72	47	No
8:45:00 AM	72	47	No
9:00:00 AM	73	47	No
9:15:00 AM	79	47	No
9:30:00 AM	73	47	No
9:45:00 AM	72	47	No
10:00:00 AM	73	47	No
10:15:00 AM	75	47	No
10:30:00 AM	72	47	No
10:45:00 AM	72	47	No
11:00:00 AM	73	47	No
11:15:00 AM	73	47	No
11:30:00 AM	75	47	No
11:45:00 AM	72	47	No
12:00:00 PM	72	47	No
12:15:00 PM	73	47	No
12:30:00 PM	73	47	No
12:45:00 PM	73	47	No
1:00:00 PM	72	47	No
1:15:00 PM	72	47	No
1:30:00 PM	75	47	No
1:45:00 PM	78	47	No
2:00:00 PM	71	47	No

RD8 Elevated Receiver			
Time	Leq15 Threshold	Predicted	Exceedance (Yes/No)
2:15:00 PM	72	47	No
2:30:00 PM	71	47	No
2:45:00 PM	71	47	No
3:00:00 PM	72	47	No
3:15:00 PM	74	47	No
3:30:00 PM	72	47	No
3:45:00 PM	72	47	No
4:00:00 PM	72	47	No
4:15:00 PM	71	47	No
4:30:00 PM	72	47	No
4:45:00 PM	72	47	No
5:00:00 PM	73	47	No
5:15:00 PM	74	47	No
5:30:00 PM	77	47	No
5:45:00 PM	74	47	No
6:00:00 PM	74	47	No
6:15:00 PM	71	47	No
6:30:00 PM	88	47	No
6:45:00 PM	78	47	No
7:00:00 PM	71	47	No
7:15:00 PM	72	47	No
7:30:00 PM	73	47	No
7:45:00 PM	71	47	No
8:00:00 PM	78	47	No
8:15:00 PM	70	47	No
8:30:00 PM	70	47	No
8:45:00 PM	71	47	No
9:00:00 PM	70	47	No
9:15:00 PM	69	47	No
9:30:00 PM	69	47	No
9:45:00 PM	70	47	No
10:00:00 PM	68	47	No
10:15:00 PM	69	47	No
10:30:00 PM	70	47	No
10:45:00 PM	67	47	No
11:00:00 PM	67	47	No
11:15:00 PM	69	47	No
11:30:00 PM	67	47	No
11:45:00 PM	70	47	No

RD8 Weekends			
Time	Leq15 Threshold	Predicted	Exceedance (Yes/No)
12:00:00 AM	66	49	No
12:15:00 AM	72	49	No
12:30:00 AM	67	49	No
12:45:00 AM	65	49	No
1:00:00 AM	64	49	No
1:15:00 AM	64	49	No
1:30:00 AM	65	49	No
1:45:00 AM	63	49	No
2:00:00 AM	63	49	No
2:15:00 AM	67	49	No
2:30:00 AM	63	49	No
2:45:00 AM	67	49	No
3:00:00 AM	65	49	No
3:15:00 AM	66	49	No
3:30:00 AM	64	49	No
3:45:00 AM	63	49	No
4:00:00 AM	62	49	No
4:15:00 AM	61	49	No
4:30:00 AM	61	49	No
4:45:00 AM	63	49	No
5:00:00 AM	61	49	No
5:15:00 AM	58	49	No
5:30:00 AM	61	49	No
5:45:00 AM	61	49	No
6:00:00 AM	60	49	No
6:15:00 AM	62	49	No
6:30:00 AM	64	49	No
6:45:00 AM	66	49	No
7:00:00 AM	65	49	No
7:15:00 AM	65	49	No
7:30:00 AM	65	49	No
7:45:00 AM	66	49	No
8:00:00 AM	68	49	No
8:15:00 AM	68	49	No
8:30:00 AM	68	49	No
8:45:00 AM	67	49	No
9:00:00 AM	67	49	No
9:15:00 AM	66	49	No
9:30:00 AM	67	49	No
9:45:00 AM	68	49	No
10:00:00 AM	69	49	No
10:15:00 AM	68	49	No
10:30:00 AM	69	49	No
10:45:00 AM	68	49	No
11:00:00 AM	68	49	No
11:15:00 AM	68	49	No
11:30:00 AM	68	49	No
11:45:00 AM	73	49	No
12:00:00 PM	68	49	No
12:15:00 PM	70	49	No
12:30:00 PM	69	49	No
12:45:00 PM	70	49	No
1:00:00 PM	69	49	No
1:15:00 PM	69	49	No
1:30:00 PM	69	49	No
1:45:00 PM	68	49	No
2:00:00 PM	70	49	No

RD8 Weekends			
Time	Leq15 Threshold	Predicted	Exceedance (Yes/No)
2:15:00 PM	69	49	No
2:30:00 PM	68	49	No
2:45:00 PM	69	49	No
3:00:00 PM	76	49	No
3:15:00 PM	69	49	No
3:30:00 PM	68	49	No
3:45:00 PM	68	49	No
4:00:00 PM	76	49	No
4:15:00 PM	68	49	No
4:30:00 PM	69	49	No
4:45:00 PM	75	49	No
5:00:00 PM	69	49	No
5:15:00 PM	68	49	No
5:30:00 PM	69	49	No
5:45:00 PM	69	49	No
6:00:00 PM	68	49	No
6:15:00 PM	69	49	No
6:30:00 PM	69	49	No
6:45:00 PM	68	49	No
7:00:00 PM	71	49	No
7:15:00 PM	70	49	No
7:30:00 PM	70	49	No
7:45:00 PM	70	49	No
8:00:00 PM	73	49	No
8:15:00 PM	70	49	No
8:30:00 PM	71	49	No
8:45:00 PM	69	49	No
9:00:00 PM	69	49	No
9:15:00 PM	69	49	No
9:30:00 PM	68	49	No
9:45:00 PM	69	49	No
10:00:00 PM	68	49	No
10:15:00 PM	69	49	No
10:30:00 PM	68	49	No
10:45:00 PM	68	49	No
11:00:00 PM	67	49	No
11:15:00 PM	67	49	No
11:30:00 PM	67	49	No
11:45:00 PM	68	49	No

RD8 Weekends Elevated Receivers			
Time	Leq15 Threshold	Predicted	Exceedance (Yes/No)
12:00:00 AM	67	47	No
12:15:00 AM	73	47	No
12:30:00 AM	67	47	No
12:45:00 AM	65	47	No
1:00:00 AM	65	47	No
1:15:00 AM	65	47	No
1:30:00 AM	65	47	No
1:45:00 AM	63	47	No
2:00:00 AM	64	47	No
2:15:00 AM	67	47	No
2:30:00 AM	64	47	No
2:45:00 AM	68	47	No
3:00:00 AM	65	47	No
3:15:00 AM	66	47	No
3:30:00 AM	64	47	No
3:45:00 AM	63	47	No
4:00:00 AM	62	47	No
4:15:00 AM	61	47	No
4:30:00 AM	62	47	No
4:45:00 AM	63	47	No
5:00:00 AM	61	47	No
5:15:00 AM	59	47	No
5:30:00 AM	61	47	No
5:45:00 AM	62	47	No
6:00:00 AM	60	47	No
6:15:00 AM	62	47	No
6:30:00 AM	64	47	No
6:45:00 AM	66	47	No
7:00:00 AM	66	47	No
7:15:00 AM	65	47	No
7:30:00 AM	66	47	No
7:45:00 AM	66	47	No
8:00:00 AM	68	47	No
8:15:00 AM	68	47	No
8:30:00 AM	68	47	No
8:45:00 AM	67	47	No
9:00:00 AM	67	47	No
9:15:00 AM	67	47	No
9:30:00 AM	67	47	No
9:45:00 AM	69	47	No
10:00:00 AM	69	47	No
10:15:00 AM	69	47	No
10:30:00 AM	69	47	No
10:45:00 AM	69	47	No
11:00:00 AM	68	47	No
11:15:00 AM	68	47	No
11:30:00 AM	68	47	No
11:45:00 AM	73	47	No
12:00:00 PM	68	47	No
12:15:00 PM	70	47	No
12:30:00 PM	70	47	No
12:45:00 PM	70	47	No
1:00:00 PM	69	47	No
1:15:00 PM	69	47	No
1:30:00 PM	70	47	No
1:45:00 PM	68	47	No
2:00:00 PM	70	47	No

RD8 Weekends Elevated Receivers			
Time	Leq15 Threshold	Predicted	Exceedance (Yes/No)
2:15:00 PM	68.8	47	No
2:30:00 PM	68.6	47	No
2:45:00 PM	69.2	47	No
3:00:00 PM	76.4	47	No
3:15:00 PM	68.9	47	No
3:30:00 PM	68	47	No
3:45:00 PM	68.3	47	No
4:00:00 PM	76.4	47	No
4:15:00 PM	68.3	47	No
4:30:00 PM	69.1	47	No
4:45:00 PM	75	47	No
5:00:00 PM	69.3	47	No
5:15:00 PM	68.1	47	No
5:30:00 PM	69.1	47	No
5:45:00 PM	69.1	47	No
6:00:00 PM	68.4	47	No
6:15:00 PM	68.8	47	No
6:30:00 PM	69	47	No
6:45:00 PM	68.2	47	No
7:00:00 PM	71	47	No
7:15:00 PM	70	47	No
7:30:00 PM	70.4	47	No
7:45:00 PM	70.1	47	No
8:00:00 PM	73	47	No
8:15:00 PM	69.8	47	No
8:30:00 PM	71.4	47	No
8:45:00 PM	69.2	47	No
9:00:00 PM	69.6	47	No
9:15:00 PM	69.6	47	No
9:30:00 PM	68.6	47	No
9:45:00 PM	69.2	47	No
10:00:00 PM	68.4	47	No
10:15:00 PM	69.5	47	No
10:30:00 PM	68.6	47	No
10:45:00 PM	68.6	47	No
11:00:00 PM	67.1	47	No
11:15:00 PM	67.5	47	No
11:30:00 PM	67.1	47	No
11:45:00 PM	68.6	47	No

RD10 Weekdays			
Time	Leq15 Threshold	Predicted	Exceedance (Yes/No)
12:00:00 AM	69	56	No
12:15:00 AM	68	56	No
12:30:00 AM	65	56	No
12:45:00 AM	65	56	No
1:00:00 AM	64	56	No
1:15:00 AM	67	56	No
1:30:00 AM	59	56	No
1:45:00 AM	63	56	No
2:00:00 AM	61	56	No
2:15:00 AM	60	56	No
2:30:00 AM	60	56	No
2:45:00 AM	58	56	No
3:00:00 AM	60	56	No
3:15:00 AM	57	56	No
3:30:00 AM	59	56	No
3:45:00 AM	61	56	No
4:00:00 AM	60	56	No
4:15:00 AM	61	56	No
4:30:00 AM	62	56	No
4:45:00 AM	63	56	No
5:00:00 AM	63	56	No
5:15:00 AM	63	56	No
5:30:00 AM	64	56	No
5:45:00 AM	66	56	No
6:00:00 AM	66	56	No
6:15:00 AM	67	56	No
6:30:00 AM	69	56	No
6:45:00 AM	71	56	No
7:00:00 AM	70	56	No
7:15:00 AM	72	56	No
7:30:00 AM	73	56	No
7:45:00 AM	71	56	No
8:00:00 AM	72	56	No
8:15:00 AM	73	56	No
8:30:00 AM	71	56	No
8:45:00 AM	71	56	No
9:00:00 AM	71	56	No
9:15:00 AM	78	56	No
9:30:00 AM	72	56	No
9:45:00 AM	73	56	No
10:00:00 AM	73	56	No
10:15:00 AM	73	56	No
10:30:00 AM	74	56	No
10:45:00 AM	74	56	No
11:00:00 AM	74	56	No
11:15:00 AM	73	56	No
11:30:00 AM	75	56	No
11:45:00 AM	72	56	No
12:00:00 PM	72	56	No
12:15:00 PM	72	56	No
12:30:00 PM	85	56	No
12:45:00 PM	73	56	No
1:00:00 PM	73	56	No
1:15:00 PM	72	56	No
1:30:00 PM	72	56	No
1:45:00 PM	75	56	No
2:00:00 PM	72	56	No



<b>RD10 Weekdays</b>			
<b>Time</b>	<b>Leq15 Threshold</b>	<b>Predicted</b>	<b>Exceedance (Yes/No)</b>
2:15:00 PM	74	56	No
2:30:00 PM	74	56	No
2:45:00 PM	74	56	No
3:00:00 PM	73	56	No
3:15:00 PM	71	56	No
3:30:00 PM	74	56	No
3:45:00 PM	72	56	No
4:00:00 PM	72	56	No
4:15:00 PM	72	56	No
4:30:00 PM	74	56	No
4:45:00 PM	72	56	No
5:00:00 PM	72	56	No
5:15:00 PM	74	56	No
5:30:00 PM	75	56	No
5:45:00 PM	74	56	No
6:00:00 PM	75	56	No
6:15:00 PM	71	56	No
6:30:00 PM	86	56	No
6:45:00 PM	76	56	No
7:00:00 PM	73	56	No
7:15:00 PM	72	56	No
7:30:00 PM	71	56	No
7:45:00 PM	71	56	No
8:00:00 PM	74	56	No
8:15:00 PM	69	56	No
8:30:00 PM	69	56	No
8:45:00 PM	68	56	No
9:00:00 PM	70	56	No
9:15:00 PM	69	56	No
9:30:00 PM	70	56	No
9:45:00 PM	69	56	No
10:00:00 PM	68	56	No
10:15:00 PM	68	56	No
10:30:00 PM	70	56	No
10:45:00 PM	69	56	No
11:00:00 PM	67	56	No
11:15:00 PM	69	56	No
11:30:00 PM	66	56	No
11:45:00 PM	65	56	No

RD10 Weekends			
Time	Leq15 Threshold	Predicted	Exceedance (Yes/No)
12:00:00 AM	65	56	No
12:15:00 AM	65	56	No
12:30:00 AM	65	56	No
12:45:00 AM	64	56	No
1:00:00 AM	63	56	No
1:15:00 AM	66	56	No
1:30:00 AM	64	56	No
1:45:00 AM	63	56	No
2:00:00 AM	64	56	No
2:15:00 AM	76	56	No
2:30:00 AM	62	56	No
2:45:00 AM	64	56	No
3:00:00 AM	66	56	No
3:15:00 AM	64	56	No
3:30:00 AM	66	56	No
3:45:00 AM	62	56	No
4:00:00 AM	63	56	No
4:15:00 AM	61	56	No
4:30:00 AM	61	56	No
4:45:00 AM	63	56	No
5:00:00 AM	57	56	No
5:15:00 AM	57	56	No
5:30:00 AM	58	56	No
5:45:00 AM	58	56	No
6:00:00 AM	58	56	No
6:15:00 AM	60	56	No
6:30:00 AM	62	56	No
6:45:00 AM	62	56	No
7:00:00 AM	63	56	No
7:15:00 AM	63	56	No
7:30:00 AM	63	56	No
7:45:00 AM	64	56	No
8:00:00 AM	67	56	No
8:15:00 AM	68	56	No
8:30:00 AM	68	56	No
8:45:00 AM	66	56	No
9:00:00 AM	68	56	No
9:15:00 AM	65	56	No
9:30:00 AM	66	56	No
9:45:00 AM	67	56	No
10:00:00 AM	67	56	No
10:15:00 AM	67	56	No
10:30:00 AM	67	56	No
10:45:00 AM	67	56	No
11:00:00 AM	69	56	No
11:15:00 AM	67	56	No
11:30:00 AM	68	56	No
11:45:00 AM	70	56	No
12:00:00 PM	68	56	No
12:15:00 PM	68	56	No
12:30:00 PM	70	56	No
12:45:00 PM	70	56	No
1:00:00 PM	71	56	No
1:15:00 PM	70	56	No
1:30:00 PM	68	56	No
1:45:00 PM	69	56	No
2:00:00 PM	69	56	No

RD10 Weekends			
Time	Leq15 Threshold	Predicted	Exceedance (Yes/No)
2:15:00 PM	69	56	No
2:30:00 PM	68	56	No
2:45:00 PM	70	56	No
3:00:00 PM	69	56	No
3:15:00 PM	68	56	No
3:30:00 PM	69	56	No
3:45:00 PM	68	56	No
4:00:00 PM	69	56	No
4:15:00 PM	68	56	No
4:30:00 PM	69	56	No
4:45:00 PM	75	56	No
5:00:00 PM	68	56	No
5:15:00 PM	69	56	No
5:30:00 PM	68	56	No
5:45:00 PM	68	56	No
6:00:00 PM	67	56	No
6:15:00 PM	68	56	No
6:30:00 PM	67	56	No
6:45:00 PM	67	56	No
7:00:00 PM	69	56	No
7:15:00 PM	69	56	No
7:30:00 PM	71	56	No
7:45:00 PM	69	56	No
8:00:00 PM	69	56	No
8:15:00 PM	68	56	No
8:30:00 PM	68	56	No
8:45:00 PM	75	56	No
9:00:00 PM	69	56	No
9:15:00 PM	68	56	No
9:30:00 PM	68	56	No
9:45:00 PM	71	56	No
10:00:00 PM	68	56	No
10:15:00 PM	70	56	No
10:30:00 PM	68	56	No
10:45:00 PM	68	56	No
11:00:00 PM	66	56	No
11:15:00 PM	66	56	No
11:30:00 PM	66	56	No
11:45:00 PM	67	56	No

RD11 Weekdays			
Time	Leq15 Threshold	Predicted	Exceedance (Yes/No)
12:00:00 AM	77	61	No
12:15:00 AM	78	61	No
12:30:00 AM	75	61	No
12:45:00 AM	74	61	No
1:00:00 AM	76	61	No
1:15:00 AM	74	61	No
1:30:00 AM	73	61	No
1:45:00 AM	77	61	No
2:00:00 AM	73	61	No
2:15:00 AM	73	61	No
2:30:00 AM	74	61	No
2:45:00 AM	72	61	No
3:00:00 AM	72	61	No
3:15:00 AM	71	61	No
3:30:00 AM	69	61	No
3:45:00 AM	75	61	No
4:00:00 AM	70	61	No
4:15:00 AM	72	61	No
4:30:00 AM	74	61	No
4:45:00 AM	75	61	No
5:00:00 AM	75	61	No
5:15:00 AM	77	61	No
5:30:00 AM	77	61	No
5:45:00 AM	78	61	No
6:00:00 AM	79	61	No
6:15:00 AM	79	61	No
6:30:00 AM	80	61	No
6:45:00 AM	81	61	No
7:00:00 AM	82	61	No
7:15:00 AM	82	61	No
7:30:00 AM	82	61	No
7:45:00 AM	82	61	No
8:00:00 AM	82	61	No
8:15:00 AM	82	61	No
8:30:00 AM	81	61	No
8:45:00 AM	81	61	No
9:00:00 AM	81	61	No
9:15:00 AM	91	61	No
9:30:00 AM	81	61	No
9:45:00 AM	81	61	No
10:00:00 AM	81	61	No
10:15:00 AM	81	61	No
10:30:00 AM	80	61	No
10:45:00 AM	80	61	No
11:00:00 AM	81	61	No
11:15:00 AM	80	61	No
11:30:00 AM	80	61	No
11:45:00 AM	81	61	No
12:00:00 PM	79	61	No
12:15:00 PM	81	61	No
12:30:00 PM	81	61	No
12:45:00 PM	81	61	No
1:00:00 PM	80	61	No
1:15:00 PM	81	61	No
1:30:00 PM	86	61	No
1:45:00 PM	87	61	No
2:00:00 PM	81	61	No

RD11 Weekdays			
Time	Leq15 Threshold	Predicted	Exceedance (Yes/No)
2:15:00 PM	80	61	No
2:30:00 PM	79	61	No
2:45:00 PM	81	61	No
3:00:00 PM	81	61	No
3:15:00 PM	81	61	No
3:30:00 PM	80	61	No
3:45:00 PM	81	61	No
4:00:00 PM	81	61	No
4:15:00 PM	81	61	No
4:30:00 PM	81	61	No
4:45:00 PM	82	61	No
5:00:00 PM	80	61	No
5:15:00 PM	87	61	No
5:30:00 PM	85	61	No
5:45:00 PM	84	61	No
6:00:00 PM	87	61	No
6:15:00 PM	80	61	No
6:30:00 PM	91	61	No
6:45:00 PM	89	61	No
7:00:00 PM	84	61	No
7:15:00 PM	81	61	No
7:30:00 PM	81	61	No
7:45:00 PM	80	61	No
8:00:00 PM	83	61	No
8:15:00 PM	80	61	No
8:30:00 PM	80	61	No
8:45:00 PM	80	61	No
9:00:00 PM	81	61	No
9:15:00 PM	80	61	No
9:30:00 PM	79	61	No
9:45:00 PM	79	61	No
10:00:00 PM	78	61	No
10:15:00 PM	78	61	No
10:30:00 PM	81	61	No
10:45:00 PM	78	61	No
11:00:00 PM	78	61	No
11:15:00 PM	79	61	No
11:30:00 PM	77	61	No
11:45:00 PM	78	61	No

RD11 Elevated Receivers			
Time	Leq15 Threshold	Predicted	Exceedance (Yes/No)
12:00:00 AM	75	64	No
12:15:00 AM	76	64	No
12:30:00 AM	73	64	No
12:45:00 AM	72	64	No
1:00:00 AM	74	64	No
1:15:00 AM	72	64	No
1:30:00 AM	71	64	No
1:45:00 AM	75	64	No
2:00:00 AM	71	64	No
2:15:00 AM	71	64	No
2:30:00 AM	72	64	No
2:45:00 AM	70	64	No
3:00:00 AM	70	64	No
3:15:00 AM	69	64	No
3:30:00 AM	67	64	No
3:45:00 AM	73	64	No
4:00:00 AM	68	64	No
4:15:00 AM	70	64	No
4:30:00 AM	72	64	No
4:45:00 AM	73	64	No
5:00:00 AM	73	64	No
5:15:00 AM	75	64	No
5:30:00 AM	75	64	No
5:45:00 AM	76	64	No
6:00:00 AM	77	64	No
6:15:00 AM	77	64	No
6:30:00 AM	78	64	No
6:45:00 AM	79	64	No
7:00:00 AM	80	64	No
7:15:00 AM	80	64	No
7:30:00 AM	80	64	No
7:45:00 AM	80	64	No
8:00:00 AM	80	64	No
8:15:00 AM	80	64	No
8:30:00 AM	79	64	No
8:45:00 AM	79	64	No
9:00:00 AM	79	64	No
9:15:00 AM	89	64	No
9:30:00 AM	79	64	No
9:45:00 AM	79	64	No
10:00:00 AM	79	64	No
10:15:00 AM	79	64	No
10:30:00 AM	78	64	No
10:45:00 AM	78	64	No
11:00:00 AM	79	64	No
11:15:00 AM	78	64	No
11:30:00 AM	78	64	No
11:45:00 AM	79	64	No
12:00:00 PM	77	64	No
12:15:00 PM	79	64	No
12:30:00 PM	79	64	No
12:45:00 PM	79	64	No
1:00:00 PM	78	64	No
1:15:00 PM	79	64	No
1:30:00 PM	84	64	No
1:45:00 PM	85	64	No
2:00:00 PM	79	64	No

<b>RD11 Elevated Receivers</b>			
<b>Time</b>	<b>Leq15 Threshold</b>	<b>Predicted</b>	<b>Exceedance (Yes/No)</b>
2:15:00 PM	78	64	No
2:30:00 PM	77	64	No
2:45:00 PM	79	64	No
3:00:00 PM	79	64	No
3:15:00 PM	79	64	No
3:30:00 PM	78	64	No
3:45:00 PM	79	64	No
4:00:00 PM	79	64	No
4:15:00 PM	79	64	No
4:30:00 PM	79	64	No
4:45:00 PM	80	64	No
5:00:00 PM	78	64	No
5:15:00 PM	85	64	No
5:30:00 PM	83	64	No
5:45:00 PM	82	64	No
6:00:00 PM	85	64	No
6:15:00 PM	78	64	No
6:30:00 PM	89	64	No
6:45:00 PM	87	64	No
7:00:00 PM	82	64	No
7:15:00 PM	79	64	No
7:30:00 PM	79	64	No
7:45:00 PM	78	64	No
8:00:00 PM	81	64	No
8:15:00 PM	78	64	No
8:30:00 PM	78	64	No
8:45:00 PM	78	64	No
9:00:00 PM	79	64	No
9:15:00 PM	78	64	No
9:30:00 PM	77	64	No
9:45:00 PM	77	64	No
10:00:00 PM	76	64	No
10:15:00 PM	76	64	No
10:30:00 PM	79	64	No
10:45:00 PM	76	64	No
11:00:00 PM	76	64	No
11:15:00 PM	77	64	No
11:30:00 PM	75	64	No
11:45:00 PM	76	64	No

RD11 Weekends			
Time	Leq15 Threshold	Predicted	Exceedance (Yes/No)
12:00:00 AM	77	61	No
12:15:00 AM	76	61	No
12:30:00 AM	78	61	No
12:45:00 AM	76	61	No
1:00:00 AM	75	61	No
1:15:00 AM	75	61	No
1:30:00 AM	76	61	No
1:45:00 AM	74	61	No
2:00:00 AM	75	61	No
2:15:00 AM	78	61	No
2:30:00 AM	75	61	No
2:45:00 AM	75	61	No
3:00:00 AM	78	61	No
3:15:00 AM	75	61	No
3:30:00 AM	77	61	No
3:45:00 AM	72	61	No
4:00:00 AM	76	61	No
4:15:00 AM	72	61	No
4:30:00 AM	74	61	No
4:45:00 AM	76	61	No
5:00:00 AM	71	61	No
5:15:00 AM	70	61	No
5:30:00 AM	73	61	No
5:45:00 AM	71	61	No
6:00:00 AM	73	61	No
6:15:00 AM	74	61	No
6:30:00 AM	75	61	No
6:45:00 AM	74	61	No
7:00:00 AM	76	61	No
7:15:00 AM	76	61	No
7:30:00 AM	76	61	No
7:45:00 AM	76	61	No
8:00:00 AM	77	61	No
8:15:00 AM	83	61	No
8:30:00 AM	77	61	No
8:45:00 AM	77	61	No
9:00:00 AM	78	61	No
9:15:00 AM	77	61	No
9:30:00 AM	78	61	No
9:45:00 AM	79	61	No
10:00:00 AM	77	61	No
10:15:00 AM	78	61	No
10:30:00 AM	78	61	No
10:45:00 AM	81	61	No
11:00:00 AM	78	61	No
11:15:00 AM	78	61	No
11:30:00 AM	78	61	No
11:45:00 AM	86	61	No
12:00:00 PM	78	61	No
12:15:00 PM	79	61	No
12:30:00 PM	80	61	No
12:45:00 PM	80	61	No
1:00:00 PM	79	61	No
1:15:00 PM	79	61	No
1:30:00 PM	79	61	No
1:45:00 PM	79	61	No
2:00:00 PM	78	61	No



RD11 Weekends			
Time	Leq15 Threshold	Predicted	Exceedance (Yes/No)
2:15:00 PM	80	61	No
2:30:00 PM	79	61	No
2:45:00 PM	78	61	No
3:00:00 PM	79	61	No
3:15:00 PM	78	61	No
3:30:00 PM	78	61	No
3:45:00 PM	78	61	No
4:00:00 PM	82	61	No
4:15:00 PM	78	61	No
4:30:00 PM	78	61	No
4:45:00 PM	82	61	No
5:00:00 PM	79	61	No
5:15:00 PM	78	61	No
5:30:00 PM	78	61	No
5:45:00 PM	82	61	No
6:00:00 PM	78	61	No
6:15:00 PM	79	61	No
6:30:00 PM	79	61	No
6:45:00 PM	78	61	No
7:00:00 PM	80	61	No
7:15:00 PM	79	61	No
7:30:00 PM	80	61	No
7:45:00 PM	80	61	No
8:00:00 PM	80	61	No
8:15:00 PM	80	61	No
8:30:00 PM	79	61	No
8:45:00 PM	79	61	No
9:00:00 PM	82	61	No
9:15:00 PM	79	61	No
9:30:00 PM	78	61	No
9:45:00 PM	80	61	No
10:00:00 PM	78	61	No
10:15:00 PM	80	61	No
10:30:00 PM	79	61	No
10:45:00 PM	78	61	No
11:00:00 PM	77	61	No
11:15:00 PM	76	61	No
11:30:00 PM	80	61	No
11:45:00 PM	81	61	No

RD11 Weekends Elevated Receivers			
Time	Leq15 Threshold	Predicted	Exceedance (Yes/No)
12:00:00 AM	75	64	No
12:15:00 AM	74	64	No
12:30:00 AM	76	64	No
12:45:00 AM	74	64	No
1:00:00 AM	73	64	No
1:15:00 AM	73	64	No
1:30:00 AM	74	64	No
1:45:00 AM	72	64	No
2:00:00 AM	73	64	No
2:15:00 AM	76	64	No
2:30:00 AM	73	64	No
2:45:00 AM	73	64	No
3:00:00 AM	76	64	No
3:15:00 AM	73	64	No
3:30:00 AM	75	64	No
3:45:00 AM	70	64	No
4:00:00 AM	74	64	No
4:15:00 AM	70	64	No
4:30:00 AM	72	64	No
4:45:00 AM	74	64	No
5:00:00 AM	69	64	No
5:15:00 AM	68	64	No
5:30:00 AM	71	64	No
5:45:00 AM	69	64	No
6:00:00 AM	71	64	No
6:15:00 AM	72	64	No
6:30:00 AM	73	64	No
6:45:00 AM	72	64	No
7:00:00 AM	74	64	No
7:15:00 AM	74	64	No
7:30:00 AM	74	64	No
7:45:00 AM	74	64	No
8:00:00 AM	75	64	No
8:15:00 AM	81	64	No
8:30:00 AM	75	64	No
8:45:00 AM	75	64	No
9:00:00 AM	76	64	No
9:15:00 AM	75	64	No
9:30:00 AM	76	64	No
9:45:00 AM	77	64	No
10:00:00 AM	75	64	No
10:15:00 AM	76	64	No
10:30:00 AM	76	64	No
10:45:00 AM	79	64	No
11:00:00 AM	76	64	No
11:15:00 AM	76	64	No
11:30:00 AM	76	64	No
11:45:00 AM	84	64	No
12:00:00 PM	76	64	No
12:15:00 PM	77	64	No
12:30:00 PM	78	64	No
12:45:00 PM	78	64	No
1:00:00 PM	77	64	No
1:15:00 PM	77	64	No
1:30:00 PM	77	64	No
1:45:00 PM	77	64	No
2:00:00 PM	76	64	No

RD11 Weekends Elevated Receivers			
Time	Leq15 Threshold	Predicted	Exceedance (Yes/No)
2:15:00 PM	77	64	No
2:30:00 PM	77	64	No
2:45:00 PM	76	64	No
3:00:00 PM	77	64	No
3:15:00 PM	76	64	No
3:30:00 PM	76	64	No
3:45:00 PM	76	64	No
4:00:00 PM	80	64	No
4:15:00 PM	76	64	No
4:30:00 PM	76	64	No
4:45:00 PM	80	64	No
5:00:00 PM	77	64	No
5:15:00 PM	76	64	No
5:30:00 PM	76	64	No
5:45:00 PM	80	64	No
6:00:00 PM	76	64	No
6:15:00 PM	77	64	No
6:30:00 PM	77	64	No
6:45:00 PM	75	64	No
7:00:00 PM	78	64	No
7:15:00 PM	77	64	No
7:30:00 PM	78	64	No
7:45:00 PM	78	64	No
8:00:00 PM	78	64	No
8:15:00 PM	78	64	No
8:30:00 PM	77	64	No
8:45:00 PM	77	64	No
9:00:00 PM	80	64	No
9:15:00 PM	77	64	No
9:30:00 PM	76	64	No
9:45:00 PM	78	64	No
10:00:00 PM	76	64	No
10:15:00 PM	78	64	No
10:30:00 PM	77	64	No
10:45:00 PM	76	64	No
11:00:00 PM	75	64	No
11:15:00 PM	74	64	No
11:30:00 PM	78	64	No
11:45:00 PM	79	64	No

RD12 Weekdays			
Time	Leq15 Threshold	Predicted	Exceedance (Yes/No)
12:00:00 AM	70	47	No
12:15:00 AM	68	47	No
12:30:00 AM	68	47	No
12:45:00 AM	69	47	No
1:00:00 AM	72	47	No
1:15:00 AM	64	47	No
1:30:00 AM	69	47	No
1:45:00 AM	67	47	No
2:00:00 AM	64	47	No
2:15:00 AM	65	47	No
2:30:00 AM	73	47	No
2:45:00 AM	70	47	No
3:00:00 AM	77	47	No
3:15:00 AM	70	47	No
3:30:00 AM	63	47	No
3:45:00 AM	67	47	No
4:00:00 AM	64	47	No
4:15:00 AM	62	47	No
4:30:00 AM	65	47	No
4:45:00 AM	72	47	No
5:00:00 AM	67	47	No
5:15:00 AM	66	47	No
5:30:00 AM	71	47	No
5:45:00 AM	72	47	No
6:00:00 AM	70	47	No
6:15:00 AM	74	47	No
6:30:00 AM	73	47	No
6:45:00 AM	72	47	No
7:00:00 AM	73	47	No
7:15:00 AM	74	47	No
7:30:00 AM	73	47	No
7:45:00 AM	74	47	No
8:00:00 AM	75	47	No
8:15:00 AM	75	47	No
8:30:00 AM	76	47	No
8:45:00 AM	75	47	No
9:00:00 AM	76	47	No
9:15:00 AM	76	47	No
9:30:00 AM	75	47	No
9:45:00 AM	77	47	No
10:00:00 AM	77	47	No
10:15:00 AM	76	47	No
10:30:00 AM	76	47	No
10:45:00 AM	75	47	No
11:00:00 AM	76	47	No
11:15:00 AM	74	47	No
11:30:00 AM	75	47	No
11:45:00 AM	76	47	No
12:00:00 PM	76	47	No
12:15:00 PM	82	47	No
12:30:00 PM	75	47	No
12:45:00 PM	76	47	No
1:00:00 PM	75	47	No
1:15:00 PM	76	47	No
1:30:00 PM	75	47	No
1:45:00 PM	75	47	No
2:00:00 PM	75	47	No

RD12 Weekdays			
Time	Leq15 Threshold	Predicted	Exceedance (Yes/No)
2:15:00 PM	75	47	No
2:30:00 PM	75	47	No
2:45:00 PM	74	47	No
3:00:00 PM	75	47	No
3:15:00 PM	75	47	No
3:30:00 PM	74	47	No
3:45:00 PM	75	47	No
4:00:00 PM	76	47	No
4:15:00 PM	74	47	No
4:30:00 PM	75	47	No
4:45:00 PM	79	47	No
5:00:00 PM	76	47	No
5:15:00 PM	74	47	No
5:30:00 PM	76	47	No
5:45:00 PM	75	47	No
6:00:00 PM	75	47	No
6:15:00 PM	74	47	No
6:30:00 PM	74	47	No
6:45:00 PM	76	47	No
7:00:00 PM	74	47	No
7:15:00 PM	73	47	No
7:30:00 PM	72	47	No
7:45:00 PM	72	47	No
8:00:00 PM	71	47	No
8:15:00 PM	72	47	No
8:30:00 PM	72	47	No
8:45:00 PM	71	47	No
9:00:00 PM	72	47	No
9:15:00 PM	72	47	No
9:30:00 PM	74	47	No
9:45:00 PM	71	47	No
10:00:00 PM	74	47	No
10:15:00 PM	73	47	No
10:30:00 PM	72	47	No
10:45:00 PM	69	47	No
11:00:00 PM	71	47	No
11:15:00 PM	71	47	No
11:30:00 PM	69	47	No
11:45:00 PM	69	47	No

RD12 Elevated Receiver			
Time	Leq15 Threshold	Predicted	Exceedance (Yes/No)
12:00:00 AM	67	49	No
12:15:00 AM	66	49	No
12:30:00 AM	65	49	No
12:45:00 AM	67	49	No
1:00:00 AM	69	49	No
1:15:00 AM	61	49	No
1:30:00 AM	67	49	No
1:45:00 AM	64	49	No
2:00:00 AM	62	49	No
2:15:00 AM	62	49	No
2:30:00 AM	70	49	No
2:45:00 AM	68	49	No
3:00:00 AM	74	49	No
3:15:00 AM	68	49	No
3:30:00 AM	61	49	No
3:45:00 AM	65	49	No
4:00:00 AM	61	49	No
4:15:00 AM	59	49	No
4:30:00 AM	63	49	No
4:45:00 AM	70	49	No
5:00:00 AM	65	49	No
5:15:00 AM	64	49	No
5:30:00 AM	68	49	No
5:45:00 AM	69	49	No
6:00:00 AM	68	49	No
6:15:00 AM	72	49	No
6:30:00 AM	70	49	No
6:45:00 AM	70	49	No
7:00:00 AM	71	49	No
7:15:00 AM	72	49	No
7:30:00 AM	71	49	No
7:45:00 AM	72	49	No
8:00:00 AM	72	49	No
8:15:00 AM	73	49	No
8:30:00 AM	74	49	No
8:45:00 AM	73	49	No
9:00:00 AM	73	49	No
9:15:00 AM	73	49	No
9:30:00 AM	72	49	No
9:45:00 AM	74	49	No
10:00:00 AM	74	49	No
10:15:00 AM	73	49	No
10:30:00 AM	73	49	No
10:45:00 AM	73	49	No
11:00:00 AM	73	49	No
11:15:00 AM	72	49	No
11:30:00 AM	72	49	No
11:45:00 AM	73	49	No
12:00:00 PM	73	49	No
12:15:00 PM	79	49	No
12:30:00 PM	73	49	No
12:45:00 PM	74	49	No
1:00:00 PM	73	49	No
1:15:00 PM	74	49	No
1:30:00 PM	73	49	No
1:45:00 PM	72	49	No
2:00:00 PM	73	49	No

<b>RD12 Elevated Receiver</b>			
<b>Time</b>	<b>Leq15 Threshold</b>	<b>Predicted</b>	<b>Exceedance (Yes/No)</b>
2:15:00 PM	72	49	No
2:30:00 PM	73	49	No
2:45:00 PM	72	49	No
3:00:00 PM	73	49	No
3:15:00 PM	72	49	No
3:30:00 PM	72	49	No
3:45:00 PM	73	49	No
4:00:00 PM	74	49	No
4:15:00 PM	72	49	No
4:30:00 PM	73	49	No
4:45:00 PM	76	49	No
5:00:00 PM	74	49	No
5:15:00 PM	72	49	No
5:30:00 PM	73	49	No
5:45:00 PM	73	49	No
6:00:00 PM	72	49	No
6:15:00 PM	72	49	No
6:30:00 PM	72	49	No
6:45:00 PM	73	49	No
7:00:00 PM	71	49	No
7:15:00 PM	70	49	No
7:30:00 PM	69	49	No
7:45:00 PM	70	49	No
8:00:00 PM	69	49	No
8:15:00 PM	69	49	No
8:30:00 PM	69	49	No
8:45:00 PM	68	49	No
9:00:00 PM	69	49	No
9:15:00 PM	70	49	No
9:30:00 PM	71	49	No
9:45:00 PM	68	49	No
10:00:00 PM	72	49	No
10:15:00 PM	70	49	No
10:30:00 PM	70	49	No
10:45:00 PM	67	49	No
11:00:00 PM	69	49	No
11:15:00 PM	68	49	No
11:30:00 PM	66	49	No
11:45:00 PM	67	49	No

RD13 Weekdays			
Time	Leq15 Threshold	Predicted	Exceedance (Yes/No)
12:00:00 AM	76	58	No
12:15:00 AM	75	58	No
12:30:00 AM	74	58	No
12:45:00 AM	88	58	No
1:00:00 AM	73	58	No
1:15:00 AM	72	58	No
1:30:00 AM	87	58	No
1:45:00 AM	82	58	No
2:00:00 AM	77	58	No
2:15:00 AM	74	58	No
2:30:00 AM	74	58	No
2:45:00 AM	71	58	No
3:00:00 AM	72	58	No
3:15:00 AM	72	58	No
3:30:00 AM	71	58	No
3:45:00 AM	71	58	No
4:00:00 AM	72	58	No
4:15:00 AM	70	58	No
4:30:00 AM	73	58	No
4:45:00 AM	75	58	No
5:00:00 AM	75	58	No
5:15:00 AM	75	58	No
5:30:00 AM	77	58	No
5:45:00 AM	77	58	No
6:00:00 AM	78	58	No
6:15:00 AM	79	58	No
6:30:00 AM	84	58	No
6:45:00 AM	86	58	No
7:00:00 AM	84	58	No
7:15:00 AM	84	58	No
7:30:00 AM	84	58	No
7:45:00 AM	82	58	No
8:00:00 AM	84	58	No
8:15:00 AM	80	58	No
8:30:00 AM	81	58	No
8:45:00 AM	81	58	No
9:00:00 AM	80	58	No
9:15:00 AM	80	58	No
9:30:00 AM	80	58	No
9:45:00 AM	79	58	No
10:00:00 AM	83	58	No
10:15:00 AM	79	58	No
10:30:00 AM	79	58	No
10:45:00 AM	79	58	No
11:00:00 AM	79	58	No
11:15:00 AM	79	58	No
11:30:00 AM	79	58	No
11:45:00 AM	79	58	No
12:00:00 PM	79	58	No
12:15:00 PM	79	58	No
12:30:00 PM	78	58	No
12:45:00 PM	78	58	No
1:00:00 PM	80	58	No
1:15:00 PM	80	58	No
1:30:00 PM	79	58	No
1:45:00 PM	79	58	No
2:00:00 PM	81	58	No



RD13 Weekdays			
Time	Leq15 Threshold	Predicted	Exceedance (Yes/No)
2:15:00 PM	78	58	No
2:30:00 PM	78	58	No
2:45:00 PM	79	58	No
3:00:00 PM	78	58	No
3:15:00 PM	79	58	No
3:30:00 PM	79	58	No
3:45:00 PM	78	58	No
4:00:00 PM	79	58	No
4:15:00 PM	85	58	No
4:30:00 PM	78	58	No
4:45:00 PM	80	58	No
5:00:00 PM	79	58	No
5:15:00 PM	78	58	No
5:30:00 PM	77	58	No
5:45:00 PM	77	58	No
6:00:00 PM	78	58	No
6:15:00 PM	78	58	No
6:30:00 PM	77	58	No
6:45:00 PM	78	58	No
7:00:00 PM	78	58	No
7:15:00 PM	78	58	No
7:30:00 PM	78	58	No
7:45:00 PM	80	58	No
8:00:00 PM	78	58	No
8:15:00 PM	78	58	No
8:30:00 PM	78	58	No
8:45:00 PM	78	58	No
9:00:00 PM	78	58	No
9:15:00 PM	78	58	No
9:30:00 PM	78	58	No
9:45:00 PM	77	58	No
10:00:00 PM	85	58	No
10:15:00 PM	79	58	No
10:30:00 PM	78	58	No
10:45:00 PM	76	58	No
11:00:00 PM	77	58	No
11:15:00 PM	77	58	No
11:30:00 PM	75	58	No
11:45:00 PM	76	58	No

RD13 Elevated Receiver			
Time	Leq15 Threshold	Predicted	Exceedance (Yes/No)
12:00:00 AM	75	59	No
12:15:00 AM	74	59	No
12:30:00 AM	73	59	No
12:45:00 AM	87	59	No
1:00:00 AM	72	59	No
1:15:00 AM	71	59	No
1:30:00 AM	86	59	No
1:45:00 AM	81	59	No
2:00:00 AM	76	59	No
2:15:00 AM	73	59	No
2:30:00 AM	73	59	No
2:45:00 AM	70	59	No
3:00:00 AM	71	59	No
3:15:00 AM	71	59	No
3:30:00 AM	70	59	No
3:45:00 AM	70	59	No
4:00:00 AM	71	59	No
4:15:00 AM	70	59	No
4:30:00 AM	72	59	No
4:45:00 AM	74	59	No
5:00:00 AM	74	59	No
5:15:00 AM	74	59	No
5:30:00 AM	76	59	No
5:45:00 AM	76	59	No
6:00:00 AM	77	59	No
6:15:00 AM	78	59	No
6:30:00 AM	83	59	No
6:45:00 AM	85	59	No
7:00:00 AM	83	59	No
7:15:00 AM	83	59	No
7:30:00 AM	83	59	No
7:45:00 AM	81	59	No
8:00:00 AM	84	59	No
8:15:00 AM	80	59	No
8:30:00 AM	80	59	No
8:45:00 AM	80	59	No
9:00:00 AM	79	59	No
9:15:00 AM	79	59	No
9:30:00 AM	79	59	No
9:45:00 AM	78	59	No
10:00:00 AM	82	59	No
10:15:00 AM	78	59	No
10:30:00 AM	78	59	No
10:45:00 AM	78	59	No
11:00:00 AM	78	59	No
11:15:00 AM	78	59	No
11:30:00 AM	78	59	No
11:45:00 AM	78	59	No
12:00:00 PM	78	59	No
12:15:00 PM	78	59	No
12:30:00 PM	77	59	No
12:45:00 PM	78	59	No
1:00:00 PM	79	59	No
1:15:00 PM	79	59	No
1:30:00 PM	78	59	No
1:45:00 PM	78	59	No
2:00:00 PM	80	59	No

RD13 Elevated Receiver			
Time	Leq15 Threshold	Predicted	Exceedance (Yes/No)
2:15:00 PM	77	59	No
2:30:00 PM	77	59	No
2:45:00 PM	78	59	No
3:00:00 PM	77	59	No
3:15:00 PM	78	59	No
3:30:00 PM	78	59	No
3:45:00 PM	77	59	No
4:00:00 PM	78	59	No
4:15:00 PM	84	59	No
4:30:00 PM	77	59	No
4:45:00 PM	79	59	No
5:00:00 PM	78	59	No
5:15:00 PM	77	59	No
5:30:00 PM	77	59	No
5:45:00 PM	76	59	No
6:00:00 PM	77	59	No
6:15:00 PM	77	59	No
6:30:00 PM	76	59	No
6:45:00 PM	77	59	No
7:00:00 PM	77	59	No
7:15:00 PM	77	59	No
7:30:00 PM	77	59	No
7:45:00 PM	79	59	No
8:00:00 PM	77	59	No
8:15:00 PM	77	59	No
8:30:00 PM	77	59	No
8:45:00 PM	77	59	No
9:00:00 PM	77	59	No
9:15:00 PM	78	59	No
9:30:00 PM	77	59	No
9:45:00 PM	76	59	No
10:00:00 PM	85	59	No
10:15:00 PM	78	59	No
10:30:00 PM	77	59	No
10:45:00 PM	75	59	No
11:00:00 PM	76	59	No
11:15:00 PM	76	59	No
11:30:00 PM	75	59	No
11:45:00 PM	75	59	No

RD13 Elevated Receiver -Weekends			
Time	Leq15 Threshold	Predicted	Exceedance (Yes/No)
12:00:00 AM	76	59	No
12:15:00 AM	75	59	No
12:30:00 AM	77	59	No
12:45:00 AM	75	59	No
1:00:00 AM	75	59	No
1:15:00 AM	75	59	No
1:30:00 AM	76	59	No
1:45:00 AM	75	59	No
2:00:00 AM	72	59	No
2:15:00 AM	81	59	No
2:30:00 AM	71	59	No
2:45:00 AM	70	59	No
3:00:00 AM	73	59	No
3:15:00 AM	73	59	No
3:30:00 AM	74	59	No
3:45:00 AM	72	59	No
4:00:00 AM	73	59	No
4:15:00 AM	73	59	No
4:30:00 AM	73	59	No
4:45:00 AM	75	59	No
5:00:00 AM	74	59	No
5:15:00 AM	75	59	No
5:30:00 AM	74	59	No
5:45:00 AM	75	59	No
6:00:00 AM	75	59	No
6:15:00 AM	75	59	No
6:30:00 AM	76	59	No
6:45:00 AM	77	59	No
7:00:00 AM	76	59	No
7:15:00 AM	77	59	No
7:30:00 AM	74	59	No
7:45:00 AM	75	59	No
8:00:00 AM	75	59	No
8:15:00 AM	75	59	No
8:30:00 AM	76	59	No
8:45:00 AM	76	59	No
9:00:00 AM	76	59	No
9:15:00 AM	75	59	No
9:30:00 AM	77	59	No
9:45:00 AM	76	59	No
10:00:00 AM	77	59	No
10:15:00 AM	76	59	No
10:30:00 AM	76	59	No
10:45:00 AM	76	59	No
11:00:00 AM	76	59	No
11:15:00 AM	79	59	No
11:30:00 AM	78	59	No
11:45:00 AM	78	59	No
12:00:00 PM	78	59	No
12:15:00 PM	75	59	No
12:30:00 PM	77	59	No
12:45:00 PM	76	59	No
1:00:00 PM	77	59	No
1:15:00 PM	85	59	No
1:30:00 PM	87	59	No
1:45:00 PM	81	59	No
2:00:00 PM	78	59	No

RD13 Elevated Receiver - Weekends			
Time	Lcq15 Threshold	Predicted	Exceedance (Yes/No)
2:15:00 PM	77	59	No
2:30:00 PM	78	59	No
2:45:00 PM	77	59	No
3:00:00 PM	76	59	No
3:15:00 PM	76	59	No
3:30:00 PM	78	59	No
3:45:00 PM	77	59	No
4:00:00 PM	76	59	No
4:15:00 PM	76	59	No
4:30:00 PM	76	59	No
4:45:00 PM	76	59	No
5:00:00 PM	81	59	No
5:15:00 PM	78	59	No
5:30:00 PM	76	59	No
5:45:00 PM	75	59	No
6:00:00 PM	76	59	No
6:15:00 PM	76	59	No
6:30:00 PM	76	59	No
6:45:00 PM	76	59	No
7:00:00 PM	77	59	No
7:15:00 PM	78	59	No
7:30:00 PM	77	59	No
7:45:00 PM	83	59	No
8:00:00 PM	80	59	No
8:15:00 PM	78	59	No
8:30:00 PM	78	59	No
8:45:00 PM	79	59	No
9:00:00 PM	78	59	No
9:15:00 PM	79	59	No
9:30:00 PM	77	59	No
9:45:00 PM	77	59	No
10:00:00 PM	77	59	No
10:15:00 PM	81	59	No
10:30:00 PM	76	59	No
10:45:00 PM	77	59	No
11:00:00 PM	77	59	No
11:15:00 PM	78	59	No
11:30:00 PM	82	59	No
11:45:00 PM	76	59	No

RD14 Elevated Receiver			
Time	Leq15 Threshold	Predicted	Exceedance (Yes/No)
12:00:00 AM	70	49	No
12:15:00 AM	70	49	No
12:30:00 AM	67	49	No
12:45:00 AM	79	49	No
1:00:00 AM	67	49	No
1:15:00 AM	65	49	No
1:30:00 AM	77	49	No
1:45:00 AM	74	49	No
2:00:00 AM	64	49	No
2:15:00 AM	65	49	No
2:30:00 AM	66	49	No
2:45:00 AM	66	49	No
3:00:00 AM	70	49	No
3:15:00 AM	67	49	No
3:30:00 AM	64	49	No
3:45:00 AM	64	49	No
4:00:00 AM	65	49	No
4:15:00 AM	65	49	No
4:30:00 AM	68	49	No
4:45:00 AM	69	49	No
5:00:00 AM	69	49	No
5:15:00 AM	72	49	No
5:30:00 AM	71	49	No
5:45:00 AM	72	49	No
6:00:00 AM	72	49	No
6:15:00 AM	72	49	No
6:30:00 AM	74	49	No
6:45:00 AM	75	49	No
7:00:00 AM	73	49	No
7:15:00 AM	74	49	No
7:30:00 AM	76	49	No
7:45:00 AM	75	49	No
8:00:00 AM	75	49	No
8:15:00 AM	74	49	No
8:30:00 AM	75	49	No
8:45:00 AM	76	49	No
9:00:00 AM	75	49	No
9:15:00 AM	76	49	No
9:30:00 AM	75	49	No
9:45:00 AM	74	49	No
10:00:00 AM	78	49	No
10:15:00 AM	74	49	No
10:30:00 AM	73	49	No
10:45:00 AM	75	49	No
11:00:00 AM	73	49	No
11:15:00 AM	73	49	No
11:30:00 AM	73	49	No
11:45:00 AM	74	49	No
12:00:00 PM	76	49	No
12:15:00 PM	74	49	No
12:30:00 PM	73	49	No
12:45:00 PM	72	49	No
1:00:00 PM	74	49	No
1:15:00 PM	74	49	No
1:30:00 PM	73	49	No
1:45:00 PM	73	49	No
2:00:00 PM	74	49	No
2:15:00 PM	73	49	No
2:30:00 PM	74	49	No

<b>RD14 Elevated Receiver</b>			
<b>Time</b>	<b>Leq15 Threshold</b>	<b>Predicted</b>	<b>Exceedance (Yes/No)</b>
2:45:00 PM	76	49	No
3:00:00 PM	74	49	No
3:15:00 PM	73	49	No
3:30:00 PM	74	49	No
3:45:00 PM	74	49	No
4:00:00 PM	74	49	No
4:15:00 PM	73	49	No
4:30:00 PM	73	49	No
4:45:00 PM	73	49	No
5:00:00 PM	73	49	No
5:15:00 PM	74	49	No
5:30:00 PM	73	49	No
5:45:00 PM	73	49	No
6:00:00 PM	74	49	No
6:15:00 PM	71	49	No
6:30:00 PM	71	49	No
6:45:00 PM	71	49	No
7:00:00 PM	73	49	No
7:15:00 PM	73	49	No
7:30:00 PM	72	49	No
7:45:00 PM	72	49	No
8:00:00 PM	72	49	No
8:15:00 PM	72	49	No
8:30:00 PM	72	49	No
8:45:00 PM	71	49	No
9:00:00 PM	71	49	No
9:15:00 PM	72	49	No
9:30:00 PM	73	49	No
9:45:00 PM	70	49	No
10:00:00 PM	79	49	No
10:15:00 PM	71	49	No
10:30:00 PM	76	49	No
10:45:00 PM	70	49	No
11:00:00 PM	70	49	No
11:15:00 PM	70	49	No
11:30:00 PM	69	49	No
11:45:00 PM	69	49	No

RD14 Elevated Receiver - Weekend			
Time	Leq15 Threshold	Predicted	Exceedance (Yes/No)
12:00:00 AM	68	49	No
12:15:00 AM	69	49	No
12:30:00 AM	68	49	No
12:45:00 AM	66	49	No
1:00:00 AM	66	49	No
1:15:00 AM	66	49	No
1:30:00 AM	66	49	No
1:45:00 AM	65	49	No
2:00:00 AM	64	49	No
2:15:00 AM	68	49	No
2:30:00 AM	64	49	No
2:45:00 AM	66	49	No
3:00:00 AM	67	49	No
3:15:00 AM	66	49	No
3:30:00 AM	66	49	No
3:45:00 AM	63	49	No
4:00:00 AM	62	49	No
4:15:00 AM	62	49	No
4:30:00 AM	63	49	No
4:45:00 AM	65	49	No
5:00:00 AM	61	49	No
5:15:00 AM	60	49	No
5:30:00 AM	64	49	No
5:45:00 AM	64	49	No
6:00:00 AM	62	49	No
6:15:00 AM	65	49	No
6:30:00 AM	66	49	No
6:45:00 AM	66	49	No
7:00:00 AM	68	49	No
7:15:00 AM	67	49	No
7:30:00 AM	68	49	No
7:45:00 AM	68	49	No
8:00:00 AM	68	49	No
8:15:00 AM	69	49	No
8:30:00 AM	68	49	No
8:45:00 AM	69	49	No
9:00:00 AM	70	49	No
9:15:00 AM	69	49	No
9:30:00 AM	69	49	No
9:45:00 AM	71	49	No
10:00:00 AM	69	49	No
10:15:00 AM	70	49	No
10:30:00 AM	69	49	No
10:45:00 AM	70	49	No
11:00:00 AM	69	49	No
11:15:00 AM	69	49	No
11:30:00 AM	70	49	No
11:45:00 AM	74	49	No
12:00:00 PM	70	49	No
12:15:00 PM	70	49	No
12:30:00 PM	71	49	No
12:45:00 PM	71	49	No
1:00:00 PM	71	49	No
1:15:00 PM	70	49	No
1:30:00 PM	69	49	No
1:45:00 PM	70	49	No
2:00:00 PM	70	49	No
2:15:00 PM	71	49	No
2:30:00 PM	70	49	No



RD14 Elevated Receiver - Weekend			
Time	Leq15 Threshold	Predicted	Exceedance (Yes/No)
2:45:00 PM	71	49	No
3:00:00 PM	72	49	No
3:15:00 PM	69	49	No
3:30:00 PM	69	49	No
3:45:00 PM	69	49	No
4:00:00 PM	74	49	No
4:15:00 PM	69	49	No
4:30:00 PM	70	49	No
4:45:00 PM	73	49	No
5:00:00 PM	70	49	No
5:15:00 PM	69	49	No
5:30:00 PM	70	49	No
5:45:00 PM	71	49	No
6:00:00 PM	69	49	No
6:15:00 PM	70	49	No
6:30:00 PM	69	49	No
6:45:00 PM	70	49	No
7:00:00 PM	71	49	No
7:15:00 PM	72	49	No
7:30:00 PM	71	49	No
7:45:00 PM	71	49	No
8:00:00 PM	71	49	No
8:15:00 PM	71	49	No
8:30:00 PM	71	49	No
8:45:00 PM	71	49	No
9:00:00 PM	71	49	No
9:15:00 PM	70	49	No
9:30:00 PM	70	49	No
9:45:00 PM	71	49	No
10:00:00 PM	69	49	No
10:15:00 PM	70	49	No
10:30:00 PM	70	49	No
10:45:00 PM	69	49	No
11:00:00 PM	69	49	No
11:15:00 PM	70	49	No
11:30:00 PM	69	49	No
11:45:00 PM	72	49	No

RD15 Weekdays			
Time	Leq15 Threshold	Predicted	Exceedance (Yes/No)
12:00:00 AM	63	60	No
12:15:00 AM	63	60	No
12:30:00 AM	63	60	No
12:45:00 AM	76	60	No
1:00:00 AM	75	60	No
1:15:00 AM	61	60	No
1:30:00 AM	74	60	No
1:45:00 AM	69	60	No
2:00:00 AM	61	60	No
2:15:00 AM	61	60	No
2:30:00 AM	64	60	No
2:45:00 AM	64	60	No
3:00:00 AM	64	60	No
3:15:00 AM	62	60	No
3:30:00 AM	64	60	No
3:45:00 AM	61	60	No
4:00:00 AM	61	60	No
4:15:00 AM	62	60	No
4:30:00 AM	63	60	No
4:45:00 AM	64	60	No
5:00:00 AM	69	60	No
5:15:00 AM	63	60	No
5:30:00 AM	65	60	No
5:45:00 AM	64	60	No
6:00:00 AM	68	60	No
6:15:00 AM	71	60	No
6:30:00 AM	78	60	No
6:45:00 AM	75	60	No
7:00:00 AM	71	60	No
7:15:00 AM	76	60	No
7:30:00 AM	71	60	No
7:45:00 AM	72	60	No
8:00:00 AM	72	60	No
8:15:00 AM	74	60	No
8:30:00 AM	75	60	No
8:45:00 AM	74	60	No
9:00:00 AM	74	60	No
9:15:00 AM	76	60	No
9:30:00 AM	76	60	No
9:45:00 AM	76	60	No
10:00:00 AM	75	60	No
10:15:00 AM	72	60	No
10:30:00 AM	70	60	No
10:45:00 AM	73	60	No
11:00:00 AM	72	60	No
11:15:00 AM	76	60	No
11:30:00 AM	71	60	No
11:45:00 AM	74	60	No
12:00:00 PM	73	60	No
12:15:00 PM	68	60	No
12:30:00 PM	71	60	No
12:45:00 PM	75	60	No
1:00:00 PM	78	60	No
1:15:00 PM	78	60	No
1:30:00 PM	75	60	No
1:45:00 PM	73	60	No

RD15 Weekdays			
Time	Leq15 Threshold	Predicted	Exceedance (Yes/No)
2:00:00 PM	76	60	No
2:15:00 PM	74	60	No
2:30:00 PM	76	60	No
2:45:00 PM	75	60	No
3:00:00 PM	75	60	No
3:15:00 PM	75	60	No
3:30:00 PM	74	60	No
3:45:00 PM	74	60	No
4:00:00 PM	73	60	No
4:15:00 PM	82	60	No
4:30:00 PM	74	60	No
4:45:00 PM	77	60	No
5:00:00 PM	69	60	No
5:15:00 PM	68	60	No
5:30:00 PM	67	60	No
5:45:00 PM	68	60	No
6:00:00 PM	70	60	No
6:15:00 PM	66	60	No
6:30:00 PM	66	60	No
6:45:00 PM	72	60	No
7:00:00 PM	68	60	No
7:15:00 PM	67	60	No
7:30:00 PM	66	60	No
7:45:00 PM	67	60	No
8:00:00 PM	66	60	No
8:15:00 PM	65	60	No
8:30:00 PM	66	60	No
8:45:00 PM	68	60	No
9:00:00 PM	68	60	No
9:15:00 PM	71	60	No
9:30:00 PM	67	60	No
9:45:00 PM	74	60	No
10:00:00 PM	82	60	No
10:15:00 PM	78	60	No
10:30:00 PM	72	60	No
10:45:00 PM	67	60	No
11:00:00 PM	65	60	No
11:15:00 PM	65	60	No
11:30:00 PM	68	60	No
11:45:00 PM	66	60	No

RD15 Elevated Receivers			
Time	Leq15 Threshold	Predicted	Exceedance (Yes/No)
12:00:00 AM	65	62	No
12:15:00 AM	65	62	No
12:30:00 AM	64	62	No
12:45:00 AM	78	62	No
1:00:00 AM	77	62	No
1:15:00 AM	63	62	No
1:30:00 AM	75	62	No
1:45:00 AM	71	62	No
2:00:00 AM	63	62	No
2:15:00 AM	63	62	No
2:30:00 AM	66	62	No
2:45:00 AM	65	62	No
3:00:00 AM	65	62	No
3:15:00 AM	63	62	No
3:30:00 AM	66	62	No
3:45:00 AM	63	62	No
4:00:00 AM	63	62	No
4:15:00 AM	63	62	No
4:30:00 AM	64	62	No
4:45:00 AM	66	62	No
5:00:00 AM	71	62	No
5:15:00 AM	65	62	No
5:30:00 AM	67	62	No
5:45:00 AM	66	62	No
6:00:00 AM	70	62	No
6:15:00 AM	72	62	No
6:30:00 AM	80	62	No
6:45:00 AM	76	62	No
7:00:00 AM	72	62	No
7:15:00 AM	77	62	No
7:30:00 AM	72	62	No
7:45:00 AM	74	62	No
8:00:00 AM	74	62	No
8:15:00 AM	75	62	No
8:30:00 AM	77	62	No
8:45:00 AM	76	62	No
9:00:00 AM	75	62	No
9:15:00 AM	77	62	No
9:30:00 AM	77	62	No
9:45:00 AM	78	62	No
10:00:00 AM	76	62	No
10:15:00 AM	74	62	No
10:30:00 AM	71	62	No
10:45:00 AM	74	62	No
11:00:00 AM	74	62	No
11:15:00 AM	78	62	No
11:30:00 AM	73	62	No
11:45:00 AM	76	62	No
12:00:00 PM	74	62	No
12:15:00 PM	70	62	No
12:30:00 PM	72	62	No
12:45:00 PM	77	62	No
1:00:00 PM	80	62	No
1:15:00 PM	80	62	No
1:30:00 PM	77	62	No
1:45:00 PM	75	62	No
2:00:00 PM	77	62	No

<b>RD15 Elevated Receivers</b>			
<b>Time</b>	<b>Leq15 Threshold</b>	<b>Predicted</b>	<b>Exceedance (Yes/No)</b>
2:15:00 PM	75	62	No
2:30:00 PM	77	62	No
2:45:00 PM	77	62	No
3:00:00 PM	76	62	No
3:15:00 PM	76	62	No
3:30:00 PM	76	62	No
3:45:00 PM	76	62	No
4:00:00 PM	75	62	No
4:15:00 PM	84	62	No
4:30:00 PM	75	62	No
4:45:00 PM	78	62	No
5:00:00 PM	70	62	No
5:15:00 PM	70	62	No
5:30:00 PM	69	62	No
5:45:00 PM	70	62	No
6:00:00 PM	71	62	No
6:15:00 PM	68	62	No
6:30:00 PM	67	62	No
6:45:00 PM	74	62	No
7:00:00 PM	69	62	No
7:15:00 PM	68	62	No
7:30:00 PM	67	62	No
7:45:00 PM	68	62	No
8:00:00 PM	68	62	No
8:15:00 PM	67	62	No
8:30:00 PM	68	62	No
8:45:00 PM	69	62	No
9:00:00 PM	70	62	No
9:15:00 PM	72	62	No
9:30:00 PM	69	62	No
9:45:00 PM	76	62	No
10:00:00 PM	83	62	No
10:15:00 PM	79	62	No
10:30:00 PM	74	62	No
10:45:00 PM	68	62	No
11:00:00 PM	67	62	No
11:15:00 PM	67	62	No
11:30:00 PM	69	62	No
11:45:00 PM	67	62	No

RD15 Elevated Receivers -Weekend			
Time	Leq15 Threshold	Predicted	Exceedance (Yes/No)
12:00:00 AM	71	62	No
12:15:00 AM	70	62	No
12:30:00 AM	70	62	No
12:45:00 AM	71	62	No
1:00:00 AM	70	62	No
1:15:00 AM	71	62	No
1:30:00 AM	70	62	No
1:45:00 AM	70	62	No
2:00:00 AM	68	62	No
2:15:00 AM	70	62	No
2:30:00 AM	68	62	No
2:45:00 AM	68	62	No
3:00:00 AM	69	62	No
3:15:00 AM	70	62	No
3:30:00 AM	70	62	No
3:45:00 AM	70	62	No
4:00:00 AM	70	62	No
4:15:00 AM	70	62	No
4:30:00 AM	79	62	No
4:45:00 AM	89	62	No
5:00:00 AM	77	62	No
5:15:00 AM	71	62	No
5:30:00 AM	69	62	No
5:45:00 AM	69	62	No
6:00:00 AM	70	62	No
6:15:00 AM	70	62	No
6:30:00 AM	70	62	No
6:45:00 AM	74	62	No
7:00:00 AM	75	62	No
7:15:00 AM	74	62	No
7:30:00 AM	72	62	No
7:45:00 AM	69	62	No
8:00:00 AM	70	62	No
8:15:00 AM	69	62	No
8:30:00 AM	70	62	No
8:45:00 AM	69	62	No
9:00:00 AM	69	62	No
9:15:00 AM	69	62	No
9:30:00 AM	70	62	No
9:45:00 AM	70	62	No
10:00:00 AM	69	62	No
10:15:00 AM	69	62	No
10:30:00 AM	70	62	No
10:45:00 AM	70	62	No
11:00:00 AM	70	62	No
11:15:00 AM	71	62	No
11:30:00 AM	72	62	No
11:45:00 AM	66	62	No
12:00:00 PM	68	62	No
12:15:00 PM	65	62	No
12:30:00 PM	64	62	No
12:45:00 PM	64	62	No
1:00:00 PM	68	62	No
1:15:00 PM	69	62	No
1:30:00 PM	76	62	No
1:45:00 PM	67	62	No
2:00:00 PM	65	62	No
2:15:00 PM	65	62	No

RD15 Elevated Receivers -Weekend			62	
Time	Leq15 Threshold		62	Exceedance (Yes/No)
2:30:00 PM	65		62	No
2:45:00 PM	74		62	No
3:00:00 PM	65		62	No
3:15:00 PM	66		62	No
3:30:00 PM	69		62	No
3:45:00 PM	68		62	No
4:00:00 PM	69		62	No
4:15:00 PM	70		62	No
4:30:00 PM	70		62	No
4:45:00 PM	70		62	No
5:00:00 PM	74		62	No
5:15:00 PM	69		62	No
5:30:00 PM	70		62	No
5:45:00 PM	70		62	No
6:00:00 PM	69		62	No
6:15:00 PM	69		62	No
6:30:00 PM	69		62	No
6:45:00 PM	70		62	No
7:00:00 PM	71		62	No
7:15:00 PM	71		62	No
7:30:00 PM	73		62	No
7:45:00 PM	76		62	No
8:00:00 PM	72		62	No
8:15:00 PM	78		62	No
8:30:00 PM	71		62	No
8:45:00 PM	71		62	No
9:00:00 PM	71		62	No
9:15:00 PM	72		62	No
9:30:00 PM	71		62	No
9:45:00 PM	71		62	No
10:00:00 PM	71		62	No
10:15:00 PM	71		62	No
10:30:00 PM	71		62	No
10:45:00 PM	72		62	No
11:00:00 PM	71		62	No
11:15:00 PM	72		62	No
11:30:00 PM	74		62	No
11:45:00 PM	71		62	No

RD16 Weekdays			
Time	Leq15 Threshold	Predicted	Exceedance (Yes/No)
12:00:00 AM	71	55	No
12:15:00 AM	72	55	No
12:30:00 AM	68	55	No
12:45:00 AM	70	55	No
1:00:00 AM	69	55	No
1:15:00 AM	65	55	No
1:30:00 AM	66	55	No
1:45:00 AM	66	55	No
2:00:00 AM	72	55	No
2:15:00 AM	69	55	No
2:30:00 AM	71	55	No
2:45:00 AM	62	55	No
3:00:00 AM	70	55	No
3:15:00 AM	63	55	No
3:30:00 AM	62	55	No
3:45:00 AM	70	55	No
4:00:00 AM	64	55	No
4:15:00 AM	67	55	No
4:30:00 AM	67	55	No
4:45:00 AM	68	55	No
5:00:00 AM	71	55	No
5:15:00 AM	72	55	No
5:30:00 AM	73	55	No
5:45:00 AM	71	55	No
6:00:00 AM	74	55	No
6:15:00 AM	76	55	No
6:30:00 AM	78	55	No
6:45:00 AM	75	55	No
7:00:00 AM	76	55	No
7:15:00 AM	81	55	No
7:30:00 AM	76	55	No
7:45:00 AM	76	55	No
8:00:00 AM	77	55	No
8:15:00 AM	75	55	No
8:30:00 AM	74	55	No
8:45:00 AM	80	55	No
9:00:00 AM	76	55	No
9:15:00 AM	79	55	No
9:30:00 AM	76	55	No
9:45:00 AM	75	55	No
10:00:00 AM	77	55	No
10:15:00 AM	75	55	No
10:30:00 AM	75	55	No
10:45:00 AM	75	55	No
11:00:00 AM	76	55	No
11:15:00 AM	76	55	No
11:30:00 AM	75	55	No
11:45:00 AM	76	55	No
12:00:00 PM	76	55	No
12:15:00 PM	76	55	No
12:30:00 PM	76	55	No
12:45:00 PM	77	55	No
1:00:00 PM	76	55	No
1:15:00 PM	76	55	No
1:30:00 PM	74	55	No
1:45:00 PM	77	55	No
2:00:00 PM	74	55	No
2:15:00 PM	75	55	No



RD16 Weekdays			
Time	Leq15 Threshold	Predicted	Exceedance (Yes/No)
2:30:00 PM	74	55	No
2:45:00 PM	75	55	No
3:00:00 PM	78	55	No
3:15:00 PM	75	55	No
3:30:00 PM	75	55	No
3:45:00 PM	75	55	No
4:00:00 PM	77	55	No
4:15:00 PM	76	55	No
4:30:00 PM	74	55	No
4:45:00 PM	76	55	No
5:00:00 PM	74	55	No
5:15:00 PM	76	55	No
5:30:00 PM	76	55	No
5:45:00 PM	76	55	No
6:00:00 PM	77	55	No
6:15:00 PM	75	55	No
6:30:00 PM	83	55	No
6:45:00 PM	78	55	No
7:00:00 PM	75	55	No
7:15:00 PM	74	55	No
7:30:00 PM	76	55	No
7:45:00 PM	77	55	No
8:00:00 PM	84	55	No
8:15:00 PM	75	55	No
8:30:00 PM	76	55	No
8:45:00 PM	76	55	No
9:00:00 PM	75	55	No
9:15:00 PM	75	55	No
9:30:00 PM	75	55	No
9:45:00 PM	80	55	No
10:00:00 PM	74	55	No
10:15:00 PM	75	55	No
10:30:00 PM	76	55	No
10:45:00 PM	74	55	No
11:00:00 PM	71	55	No
11:15:00 PM	73	55	No
11:30:00 PM	70	55	No
11:45:00 PM	76	55	No

RD16 Weekends			
Time	Leq15 Threshold	Predicted	Exceedance (Yes/No)
12:00:00 AM	70	55	No
12:15:00 AM	73	55	No
12:30:00 AM	73	55	No
12:45:00 AM	71	55	No
1:00:00 AM	68	55	No
1:15:00 AM	69	55	No
1:30:00 AM	77	55	No
1:45:00 AM	67	55	No
2:00:00 AM	74	55	No
2:15:00 AM	80	55	No
2:30:00 AM	72	55	No
2:45:00 AM	72	55	No
3:00:00 AM	77	55	No
3:15:00 AM	77	55	No
3:30:00 AM	73	55	No
3:45:00 AM	68	55	No
4:00:00 AM	75	55	No
4:15:00 AM	71	55	No
4:30:00 AM	72	55	No
4:45:00 AM	72	55	No
5:00:00 AM	62	55	No
5:15:00 AM	64	55	No
5:30:00 AM	66	55	No
5:45:00 AM	68	55	No
6:00:00 AM	64	55	No
6:15:00 AM	74	55	No
6:30:00 AM	68	55	No
6:45:00 AM	69	55	No
7:00:00 AM	68	55	No
7:15:00 AM	69	55	No
7:30:00 AM	70	55	No
7:45:00 AM	69	55	No
8:00:00 AM	73	55	No
8:15:00 AM	69	55	No
8:30:00 AM	72	55	No
8:45:00 AM	71	55	No
9:00:00 AM	71	55	No
9:15:00 AM	71	55	No
9:30:00 AM	72	55	No
9:45:00 AM	73	55	No
10:00:00 AM	73	55	No
10:15:00 AM	75	55	No
10:30:00 AM	74	55	No
10:45:00 AM	75	55	No
11:00:00 AM	71	55	No
11:15:00 AM	71	55	No
11:30:00 AM	72	55	No
11:45:00 AM	74	55	No
12:00:00 PM	74	55	No
12:15:00 PM	72	55	No
12:30:00 PM	73	55	No
12:45:00 PM	75	55	No
1:00:00 PM	74	55	No
1:15:00 PM	74	55	No
1:30:00 PM	74	55	No
1:45:00 PM	74	55	No
2:00:00 PM	75	55	No

RD16 Weekends			
Time	Leq15 Threshold	Predicted	Exceedance (Yes/No)
2:15:00 PM	74	55	No
2:30:00 PM	73	55	No
2:45:00 PM	72	55	No
3:00:00 PM	74	55	No
3:15:00 PM	73	55	No
3:30:00 PM	72	55	No
3:45:00 PM	72	55	No
4:00:00 PM	75	55	No
4:15:00 PM	75	55	No
4:30:00 PM	73	55	No
4:45:00 PM	74	55	No
5:00:00 PM	73	55	No
5:15:00 PM	74	55	No
5:30:00 PM	73	55	No
5:45:00 PM	73	55	No
6:00:00 PM	71	55	No
6:15:00 PM	73	55	No
6:30:00 PM	72	55	No
6:45:00 PM	75	55	No
7:00:00 PM	74	55	No
7:15:00 PM	74	55	No
7:30:00 PM	75	55	No
7:45:00 PM	74	55	No
8:00:00 PM	74	55	No
8:15:00 PM	75	55	No
8:30:00 PM	75	55	No
8:45:00 PM	76	55	No
9:00:00 PM	75	55	No
9:15:00 PM	76	55	No
9:30:00 PM	75	55	No
9:45:00 PM	75	55	No
10:00:00 PM	77	55	No
10:15:00 PM	76	55	No
10:30:00 PM	73	55	No
10:45:00 PM	75	55	No
11:00:00 PM	73	55	No
11:15:00 PM	75	55	No
11:30:00 PM	72	55	No
11:45:00 PM	73	55	No

**MTA PURPLE LINE SECTION 2 PROJECT  
NOISE CONTROL PLAN MOA CONDITIONS  
Wilshire/Rodeo Station Entrance Excavation**



November 4, 2020

Submitted by:



*Engineered Solutions*

Submitted to:

**TUTOR PERINI/O&G, JV**

**1801 Century Park East, Ste. 500**

**Los Angeles, CA 90067**





## Contents

<b>1. Introduction.....</b>	<b>3</b>
<b>2. Construction Schedule.....</b>	<b>3</b>
<b>3. SoundPLAN.....</b>	<b>3</b>
<b>4. Noise Control Plan .....</b>	<b>5</b>
<b>4.1 Construction Equipment .....</b>	<b>5</b>
<b>4.2 Site Plan and Discussions .....</b>	<b>5</b>
<b>4.3 Results and Observations .....</b>	<b>9</b>
<b>5. Mitigation Measures .....</b>	<b>10</b>
<b>APPENDIX A - Excavator Noise Certificate.....</b>	<b>11</b>
<b>APPENDIX B – Ventilation Fan Noise Certificate .....</b>	<b>13</b>
<b>APPENDIX C – Ventilation Metal Grate Noise Measurement .....</b>	<b>16</b>
<b>APPENDIX D - Noise Level Predictions.....</b>	<b>21</b>

## 1. Introduction

The aim of this study is to analyze and predict the construction noise levels during excavation at Station Entrance and hauling operations at Wilshire/Reeves. The excavation site is located directly in front of staging yard at 9430 Wilshire Blvd. The site is surrounded by high rise office spaces alongside Wilshire Blvd. The residential buildings are located to the east and south of the excavation site. Commercial structures are located to the south as well as north across Wilshire Blvd.

## 2. Construction Schedule

The excavation work will start in second week of June 2020.

## 3. SoundPLAN

The sound model for the excavation was developed for continuous noise generation during the daily work shifts. *SoundPLAN* was configured with settings outlined in Table 1. The noise modelling was performed using *SoundPLAN* version 8.1, which calculates outdoor noise propagation based upon the methodology specified in ISO 9613 -2.

Table 1 *SoundPLAN* Noise Prediction Model Settings

<b>Prediction Model:</b>	ISO 9613 -2 "Acoustics -- Attenuation of sound during propagation outdoors -- Part 2: General method of calculation", 1993
<b>Air absorption:</b>	ISO 9613-1 "Acoustics -- Attenuation of sound during propagation outdoors -- Part 1: Calculation of the absorption of sound by the atmosphere"
<b>Environment:</b>	
Air pressure	1013 mbar
rel. Humidity	70%
Temperature	25 °C = 77 °F
<b>Maximum Screening Loss:</b>	
<b>Assessment:</b>	Leq
<b>Frequency Weighting:</b>	dBA
<b>Ground:</b>	Reflective Ground $g=0$

Note:

- The accuracy of a noise model depends on several parameters such as source input (sound power level, spectral content, operation consideration), modeling standard settings, and noise prediction parameters.
- The excavation area was modeled using the *SoundPLAN* noise modeling software. The prediction uses the ISO 9613 -2 [Acoustics -- attenuation of sound during propagation outdoors -- Part 2: General Method of Calculation", 1993] prediction standard. *SoundPLAN* follows and meets the requirements developed for quality assurance of software implementation of ISO 9613-2 [ISO 175343 Acoustics -- software for the calculation of sound outdoors -- Part 3: Recommendations for quality assured implementation of ISO 9613-2].
- The ISO 9613-2 standard was developed with slight downwind and inversion condition which typically overpredicts than under-predict the noise levels. The FHWA emission data do also tend to be conservative and overestimate the equipment noise generation.
- Regarding the overall predicted sound level, the model assumes that all equipment operates at the same time, which is a conservative prediction process.
- The equipment sound power level inputs were based on measured data provided by TPOG, Specification 01 56 19 and data published by FHWA - Table 1. Construction Equipment Noise Emission Levels ([https://ops.fhwa.dot.gov/wz/workshops/accessible/Schexnayder\\_paper.htm](https://ops.fhwa.dot.gov/wz/workshops/accessible/Schexnayder_paper.htm)). The FHWA data typically does not reflect the newest noise control technology and provide a conservative assessment with higher input sound power levels.



## 4. Noise Control Plan

The noise control plan was developed based on the situation below:

- Excavation and Hauling operational for 24 hours/day.
- Excavation site is surrounded by variable height of Noise Barrier ranging from 20 ft to 10.75 ft.

It should be noted that if the excavation location is modified or addition locations are added, further updated noise control plans will be provided. Also, the noise control plan will be updated quarterly.

### 4.1 Construction Equipment

Construction equipment list shown in Table 2 was used for the model development. Please refer to Table 2 for the equipment specification,

Table 2. Sound Power Levels

Name (Source Height)	Lw (dbA)	Noise Levels @ 50 ft (dbA)	Utilization
Dump Trucks (Height 12 ft)	105	75	66%
Haul Route (Height 12ft, Speed 20mph)	105	75	Noise Exposure -10%***
Excavators (Height 8 ft)	109	79	80%
Ventilation Fan (Height 3ft)	112	82	100%
Ventilation Metal Grate -- Modeled as two separate point sources* (At ground Elev)	89	59	100%

- Note: Noise Levels at 50 ft were provided by TPOG, Equipment are not subjected to requirements beyond specification 01 56 19
- \*Noise Power Levels for Metal grate was calculated by using the Noise Measurement Data provided by Metro, Noise Silencer was used to reduce the noise from the intake, see Appendix
- Please refer to Appendix C for Noise Certification. \*\*\* Equipment Noise Certification for ventilation fans is attached in Appendix.
- Note: The sound Power Levels were calculated from the Noise Levels @50 ft as shown in the table below ( $L_w = L_{50} + 20 \log (50 \times 0.3048) + 8$ )
- \*\*\*The Noise Exposure from Haul route is calculated at 20 mph. The trucks are anticipated to pass the sensitive receivers every 5 minutes, creating noise exposure of 30 seconds for each receiver for 5 minute period or 90 seconds every 15 mins or 10%.

### 4.2 Site Plan and Discussions

The Baseline Model for situation is shown Figure 1, it includes all equipment that would be operational during excavation. Noise Barrier (NRC=0.85) is indicated as blue boundary. The Noise Barrier is positioned as a continuous wall; Noise barrier height is indicated on figure 1.

Noise Sensitive locations as per MOA conditions are shown in Figure 2. The residential buildings are shown in blue; hotels are shown as light green; and commercial buildings are striped. The buildings were modeled at their full height; varying floor heights were identified.

To make the model conservative, Excavator was modeled as an area source. The Truck Haul Route was added as a line source whereas use of the Dump Truck was modeled as a point source. The Utilization factors for Excavator is taken to be 80 %. The sound power level used for the excavator are based on the





field measurement of the sound levels at 50 ft (see appendix for certificate). The excavator is not to exceed 79 dBA noise levels at 50 ft during the construction operation as indicated on the certificate.

Note that *Sound Plan* includes functionality to calculate the effective noise power levels from Stationary Noise Levels and the speed of the Line Noise Source. The noise exposure from the haul route will be around 90 seconds for 15 minutes interval considering 30 seconds exposure during each 5 minutes dump cycle.

Along with the Haul Route, excavator, and dump trucks a ventilation fan was also added in the noise control plan at Canon Yard. A 20ft high noise wall is installed around the Canon Yard, also shown in green in Figure 2. An additional 14 feet high noise wall was modeled around the Ventilation Fan as shown in figure 1. The maximum operational noise value for the ventilation fans shall be 82 dBA at 50 feet per the noise certificate attached in the appendix.

Ventilation intake located at Wilshire/Beverly Dr. was also included in the noise model. The Sound Power Levels for the Ventilation grate were calculated from the noise measurement provided by Metro (see Appendix). The ventilation intake was modeled as two-point source to match the noise profile provided by the measurement results.

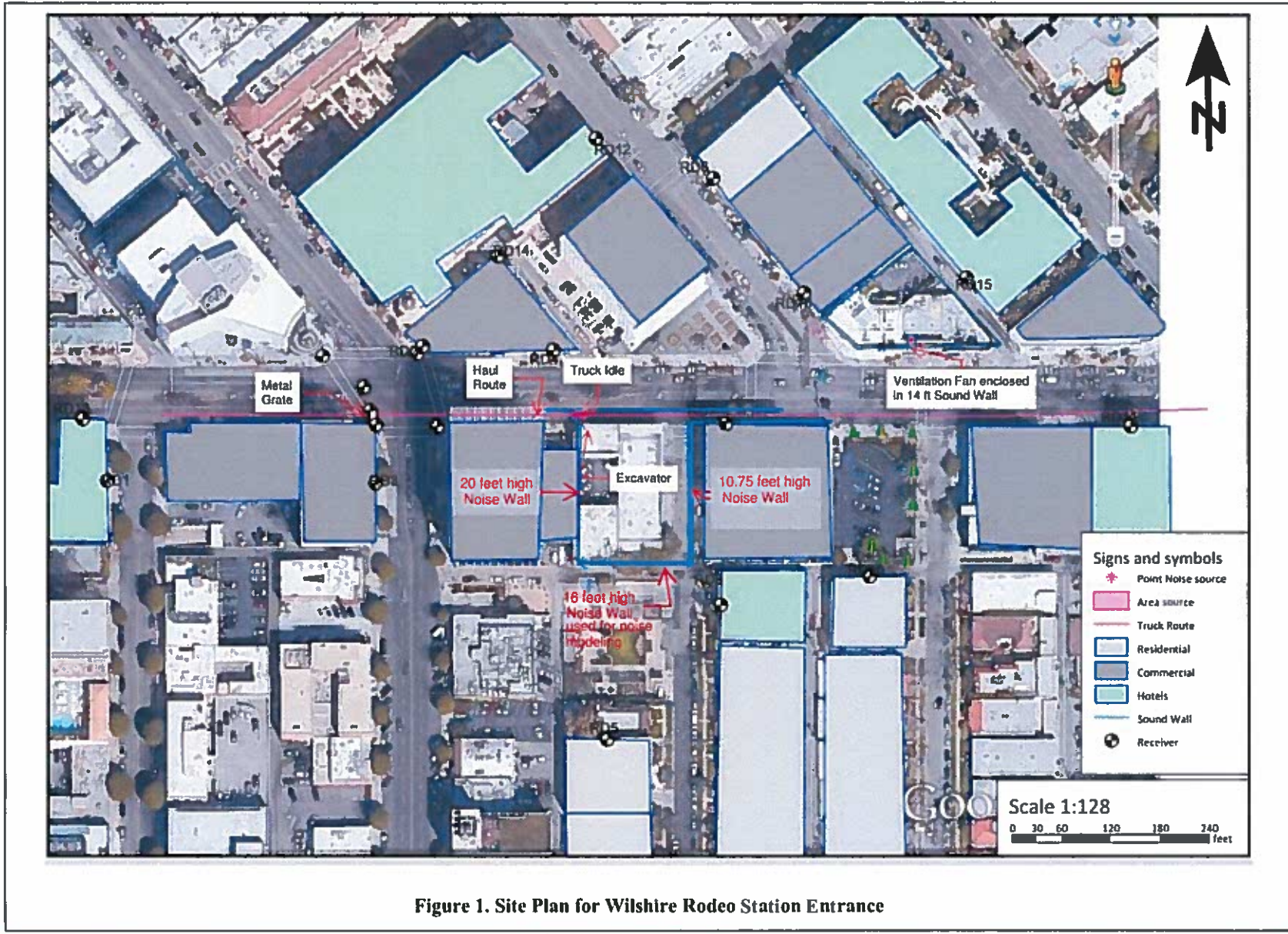



Figure 2. Sensitive Noise Locations around Wilshire Rodeo Station Excavation



#### **4.3 Results and Observations**

Noise predictions for 24 h are presented in Appendix B. Threshold limits at the receivers established by CSDA are used for comparing predicted noise levels. As Excavator noise levels were reduced as per report attached in Appendix A.

No Exceedances were predicted for the planned construction work except for Receptor RD-5 when working during weekend between 5:15 AM and 5:30 AM where the threshold is 54 dBA and the predicted noise is 55dBA.

The aforementioned exceedance shall be eliminated by switching off dump trucks for 15 minutes interval starting at 5:15 AM when working during weekends. This will reduce the predicted noise at RD-5 to 52 dBA. The updated results for RD-5 are shown in Appendix D.

Noise from a construction activity and/or construction equipment shall comply with all noise requirements identified in Article XIV of the MOA, which includes the Lmax noise limits. If the activity, the equipment in use and/or the sound enclosure for the equipment are modified or the equipment is operated at a location not identified in the noise control plan, the noise control plan shall be revised to address the changed conditions and resubmitted to the City for review and approval. The use of non-compliant equipment and/or engaging in a construction activity that exceeds the MOA identified noise limits including Lmax noise level shall not continue until the City approves a noise control plan revision and/or the implementation of noise mitigation to ensure that the equipment complies with noise limits identified in Article XIV.

## **5. Mitigation Measures**

Based on the simulations following mitigation measures will be taken:

- 1) Excavation area will be surrounded by variable height Noise Barrier as discussed in previous sections (NRC= 0.85).
- 2) If noise levels exceed during nighttime equipment utilization will be reduced to meet the threshold.
- 3) If during noise monitoring Lmax level exceeds the threshold value following actions will be taken:
  1. Contractor shall switch equipment to meet noise requirements. OR
  2. Contractor shall modify work hours to meet noise requirements. OR
  3. Contractor shall use other available noise reduction measures.
- 4) To reduce noise levels at Wilshire / Beverly intake grate, install additional silencer at each intake fan, see Appendix C for silencer product data



## **APPENDIX A - Excavator Noise Certificate**



Los Angeles County Metropolitan Transportation Authority  
Westside Purple Line Extension Project, Section 2

**FIGURE 3**

**EQUIPMENT NOISE LEVEL DATA REPORTING FORM**

**APPLICATION FOR CERTIFICATE OF EQUIPMENT NOISE COMPLIANCE**

Contractor Name: TPOGJV  
Contract Name & Number: Tutor Perini and O&G JV,

Equipment Type: Excavator  
Manufacturer & Model Number: CAT 390  
Identification Number: FHHNG00186  
Rated Power & Capacity: 406 HP  
Operating Condition During Test: Good- (Noise Reduction Measures)

**Measured Sound Levels at 20 to 50 feet:**

Measured Values and Distance:

Right Side: 78.4 dBA (SLOW), at 50 feet  
Left Side: 79 dBA (SLOW), at 50 feet

Estimated Values at 50-Foot Distance:

Right Side: \_\_\_\_\_ dBA (SLOW).  
Left Side: \_\_\_\_\_ dBA (SLOW).

Maximum Values Allowed for this Equipment: 81 (As per Specs 01 56 19) dBA (SLOW) at 50 feet.

If equipment sound level exceeds maximum value allowed, indicate action taken to achieve compliance:

\_\_\_\_\_  
\_\_\_\_\_  
\_\_\_\_\_

Name, Address & Phone No. of Acoustical Engineer: Dr. Dots Oyenuqa, 3767 Overland Avenue, Los Angeles 90034, Suite 115, +1 -510 207 1387

Authorized Signature:  Date: 6/12/20  
CONTRACTOR'S APPROVAL: \_\_\_\_\_ Date: \_\_\_\_\_  
Authorized Signature: \_\_\_\_\_ Date: \_\_\_\_\_  
ENGINEER'S CONCURRENCE: \_\_\_\_\_ Date: \_\_\_\_\_  
Authorized Signature: \_\_\_\_\_ Date: \_\_\_\_\_



## **APPENDIX B – Ventilation Fan Noise Certificate**





**EQUIPMENT NOISE LEVEL DATA REPORTING FORM**

**APPLICATION FOR CERTIFICATE OF EQUIPMENT NOISE COMPLIANCE**

Contractor Name: TPOG  
Contract Name & Number: MTA Purple line Extension 2 , C1120

Equipment Type: Ventilation Fan  
Manufacturer & Model Number: R-5300-B-SS-XP  
Identification Number: 300 HP  
Rated Power & Capacity: \_\_\_\_\_  
Operating Condition During Test: Sunny, Clear Sky

**Measured Sound Levels at 20 to 50 feet:**

Measured Values and Distance: There were obstructions blocking the right side of the ventilation fans, as a result of which the noise level for right side is lower than the left.

Right Side: 76.4 dBA (SLOW), at 50 feet  
Left Side: 82.4 dBA (SLOW), at 50 feet

Estimated Values at 50-Foot Distance:

Right Side: \_\_\_\_\_ dBA (SLOW).  
Left Side: \_\_\_\_\_ dBA (SLOW).

Maximum Values Allowed for this Equipment: 85 dBA (SLOW) at 50 feet.

Note: Equipment was operated at maximum governed rpm under full load conditions during the tests. All tests were performed under the supervision of the Acoustical Engineer.

If equipment sound level exceeds maximum value allowed, indicate action taken to achieve compliance:  
\_\_\_\_\_  
\_\_\_\_\_

Name, Address & Phone No. of Acoustical Engineer: Dr. Dots Oyenuga, 3767 Overland Avenue, Suite # 115, (510) 207 1387

Authorized Signature: \_\_\_\_\_ Date: 02/20/20  
CONTRACTOR'S APPROVAL:  
Authorized Signature: \_\_\_\_\_ Date: \_\_\_\_\_  
ENGINEER'S CONCURRENCE:  
Authorized Signature: \_\_\_\_\_ Date: \_\_\_\_\_

# JETAIR

A Division of Mining Equipment Limited

JETAIR FANS  
 P.O. BOX 2118  
 EL-BLANCO CO. 81802  
 PH (978) 259-0412  
 www.jetairfans.com

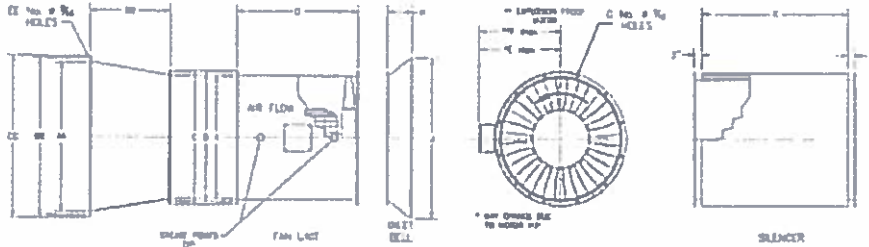

SINGLE STAGE FAN WITH ADJUSTABLE PITCH

FAN No.	PLATE No.	BASE No.
50-1000-01	80	100
42-1000-02	80	100
50-1000-03	80	100

CASE DIA	DIMENSIONS (INCHES)																		
	FAN LIFT									INLET/OUTLET CONE				INLET BELL		SILENCER	CASE DIA		
	Please set for Dia. P									AA	BB	CC	DD	EE	FF	GG		HH	
MM	NN	OO	PP	QQ	RR	SS	TT	UU	AA	BB	CC	DD	EE	FF	GG	HH			
18	2-1/2	3000	14	19.75	21.25	29	17	12	27	23.75	25.25	27	37	4	23.57	30	18		
21 1/4	3-1/2	3700	17	23.50	25.00	30	19	12	29	27.75	29.25	30	37	4.57	27.90	42	21.50		
23 1/4	3-1/2	3500	14	23.50	25.00	30	19	12	29	29.50	31.00	31	37	8	31.50	40	23.50		
23 1/4	3-1/2	3500	14	23.50	25.00	30	19	12	29	30.75	32.25	32	37	8.57	33	40	23.50		
27 1/4	3-1/2	3700	14	27.75	29.25	30	21	12	30	30.75	32.25	32	37	8	33.57	54	27.50		
29 1/4	3-1/2	3500	14	29.75	31.25	30	21	12	30	31.75	33.25	33	37	8	35.57	54	29.50		
31 1/4	3-1/2	3500	14	31.75	33.25	30	21	12	30	33.75	35.25	35	37	8	37.57	54	31.50		
31 1/4	3-1/2	3500	14	31.75	33.25	30	21	12	30	35.75	37.25	37	37	8	39.57	54	31.50		
35	3-1/2	3500	14	35.75	37.25	30	23	12	32	41.75	43.25	43	37	8	45.57	60	35.50		
35	3-1/2	3500	14	35.75	37.25	30	23	12	32	43.75	45.25	45	37	8	47.57	60	35.50		
39	3-1/2	3500	14	39.75	41.25	30	25	12	34	47.75	49.25	49	37	8	51.57	66	39.50		
42 1/4	3-1/2	3500	14	42.75	44.25	30	27	12	36	51.75	53.25	53	37	8	55.57	72	42.50		
42 1/4	3-1/2	3500	14	42.75	44.25	30	27	12	36	53.75	55.25	55	37	8	57.57	72	42.50		
47 1/4	3-1/2	3500	14	47.75	49.25	30	31	12	40	61.75	63.25	63	37	8	65.57	84	47.50		
47 1/4	3-1/2	3500	14	47.75	49.25	30	31	12	40	63.75	65.25	65	37	8	67.57	84	47.50		
49	3-1/2	3500	14	49.75	51.25	30	31	12	40	65.75	67.25	67	37	8	69.57	84	49.50		
49	3-1/2	3500	14	49.75	51.25	30	31	12	40	67.75	69.25	69	37	8	71.57	84	49.50		
54	3-1/2	3500	14	54.75	56.25	30	35	12	44	75.75	77.25	77	37	8	79.57	96	54.50		
54	3-1/2	3500	14	54.75	56.25	30	35	12	44	77.75	79.25	79	37	8	81.57	96	54.50		
59	3-1/2	3500	14	59.75	61.25	30	39	12	48	83.75	85.25	85	37	8	87.57	108	59.50		
59	3-1/2	3500	14	59.75	61.25	30	39	12	48	85.75	87.25	87	37	8	89.57	108	59.50		
63	3-1/2	3500	14	63.75	65.25	30	43	12	52	91.75	93.25	93	37	8	95.57	120	63.50		
63	3-1/2	3500	14	63.75	65.25	30	43	12	52	93.75	95.25	95	37	8	97.57	120	63.50		
67	3-1/2	3500	14	67.75	69.25	30	47	12	56	99.75	101.25	101	37	8	103.57	132	67.50		
67	3-1/2	3500	14	67.75	69.25	30	47	12	56	101.75	103.25	103	37	8	105.57	132	67.50		
72	3-1/2	3500	14	72.75	74.25	30	51	12	60	107.75	109.25	109	37	8	111.57	144	72.50		
72	3-1/2	3500	14	72.75	74.25	30	51	12	60	109.75	111.25	111	37	8	113.57	144	72.50		
76	3-1/2	3500	14	76.75	78.25	30	55	12	64	115.75	117.25	117	37	8	119.57	156	76.50		
76	3-1/2	3500	14	76.75	78.25	30	55	12	64	117.75	119.25	119	37	8	121.57	156	76.50		
81	3-1/2	3500	14	81.75	83.25	30	59	12	68	123.75	125.25	125	37	8	127.57	168	81.50		
81	3-1/2	3500	14	81.75	83.25	30	59	12	68	125.75	127.25	127	37	8	129.57	168	81.50		
84	3-1/2	3500	14	84.75	86.25	30	63	12	72	131.75	133.25	133	37	8	135.57	180	84.50		
84	3-1/2	3500	14	84.75	86.25	30	63	12	72	133.75	135.25	135	37	8	137.57	180	84.50		
89	3-1/2	3500	14	89.75	91.25	30	67	12	76	139.75	141.25	141	37	8	143.57	192	89.50		
89	3-1/2	3500	14	89.75	91.25	30	67	12	76	141.75	143.25	143	37	8	145.57	192	89.50		

## **APPENDIX C – Ventilation Metal Grate Noise Measurement**

### Noise Measurement Data

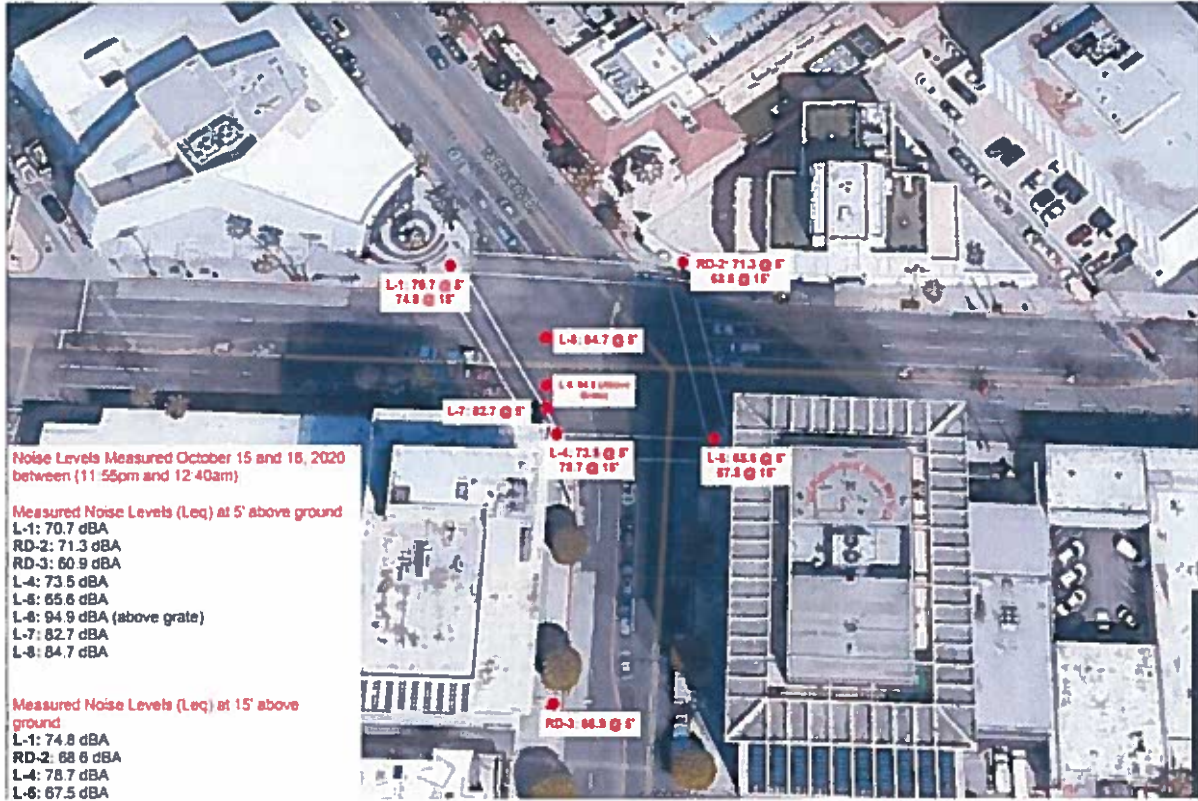

Calculated Sound Power Level



Receiver Point	Leq
L-1 (5ft)	70.7
RD-2	68
RD-2 (15 ft)	70
RD-3	61.8
L-1 (15 ft)	74.8
L-4 (5ft)	75.3
L-4 (15 ft)	77.2
L-5 (5ft)	67.3
L-5 (15 ft)	69.6
L-6 (5ft)	100
L-7 (5ft)	81.5
L-8 (5ft)	84

Ventilation Intake Silencer- Product Data

VIBROACOUSTICS®

Noise Control | Vibration Isolation | Restraint Systems

tel: 416-291-7371 1-800-565-8401 web: www.vibro-acoustics.com  
 fax: 416-291-8049 1-888-811-2264 email: info@vibro-acoustics.com

CIRCULAR DISSIPATIVE

CD

File No.: 03A-003 Date: 17 Sep 2013  
 Supersedes: 03A-002 Date: 19 Aug 2013

QTY: <b>2</b>	TAG: SA-1,SA-2		
Submitted for: <b>Approval</b>	Dwg #: <b>26170-1</b>	Rev. #: <b>0</b>	Drawn by: _____
Project: <b>Metro PLE2</b>		Customer: <b>CSDA Design Group</b>	Customer P.O. No. _____
V.A Project No. <b>1142142</b>	V.A Project Manager _____	Consultant _____	

Performance for Model CD UHV F1

Airflow	Velocity	Pressure Drop	Pressure Drop w/ System Effects*	Dynamic Insertion Loss (dB)									
				63 Hz	125 Hz	250 Hz	500 Hz	1 KHz	2 KHz	4 KHz	8 KHz		
CFM (L/s)	FPM (m/s)	in.w.g. (Pa)	in.w.g. (Pa)										
51000 (24,162)	4050 (21)	0.03 (6)	0.04 (11)	0	11	14	13	8	7	5	4		

Silencer performance data has been obtained from tests conducted in a laboratory facility NVLAP accredited for the ASTM E477-06a test standard. \* Duct configuration must be known for at least 5 duct diameters upstream and downstream of the silencer to determine pressure drop with system effects

Dimensions and Weights

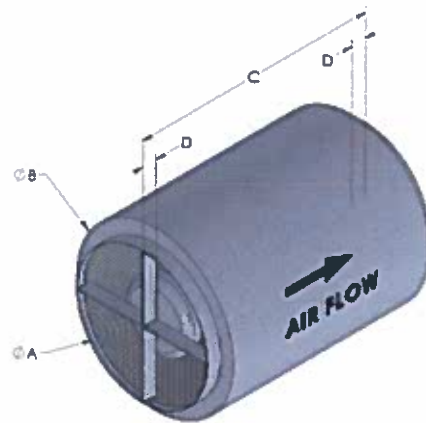

Silencer Size (in/mm)				Total Wt
A	B	C	D	(lb/kg)
48	64	84	2	1,053

Construction

Casing	19 Ga (2.75 mm) Galvanized
	Continuously Welded
Perforated Liner	22 Ga (0.45 mm) Galvanized
Media Fill	Acoustic Grade Glass Fiber
Media Protection	None
End connections	2" (51 mm) slip connection
Accessories	None

Ratings

Pressure rating	8 w.F.O. (102 Pa)	
Combustion rating (ASTM E84 or CAN/ULC S102)	Flame spread classification	< 25
	Smoke development rating	< 50

Notes

- Customer to confirm all dimensions.
- Silencer construction meets applicable requirements of SMACNA Duct Construction Standards, ASHRAE 62.1, UL181, ASTM C1071, NFPA 90A and NFPA 90B.
- Lubricants and sealants used during manufacturing may contain silicone.
- Gauges and thicknesses are based on SMACNA standard nominal and will vary within prescribed tolerances.
- Electronic document links:
  - Disipative Straight Silencers
  - Installation Instructions / Operation & Maintenance
  - NVLAP Accreditation

Calculated Sound Power Level after using Noise Silencer for the Vent intake

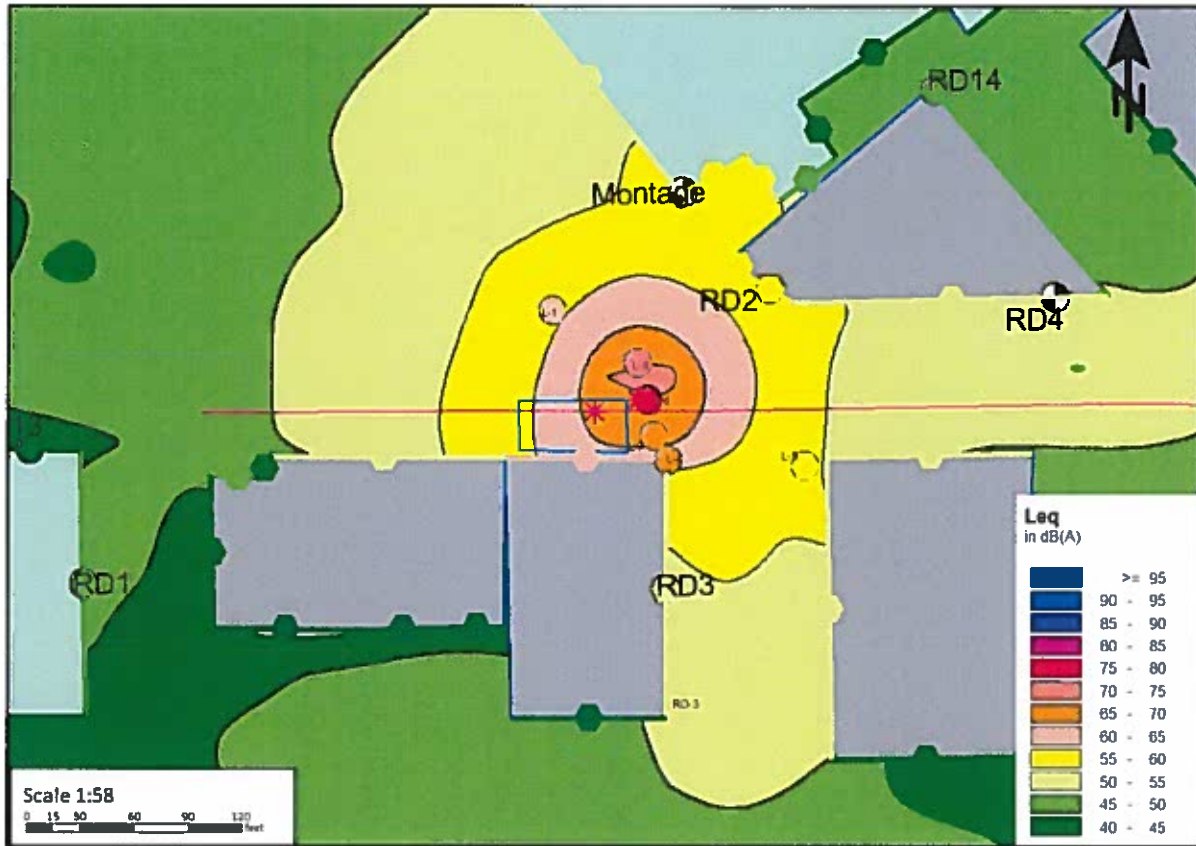

Receiver Point	Leq
L-1 (5ft)	59
RD-2	56
RD-2 (15 ft)	58
RD-3	50
L-1 (15 ft)	61
L-4 (5ft)	63.3
L-4 (15 ft)	66
L-5 (5ft)	56
L-5 (15 ft)	58
L-6 (5ft)	79
L-7 (5ft)	69
L-8 (5ft)	72.2



## **APPENDIX D - Noise Level Predictions**



Leq  
in dB(A)

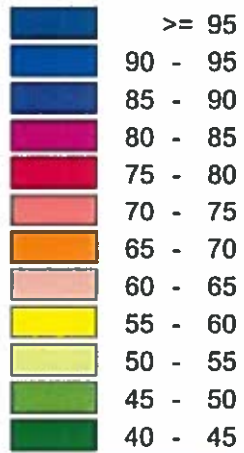

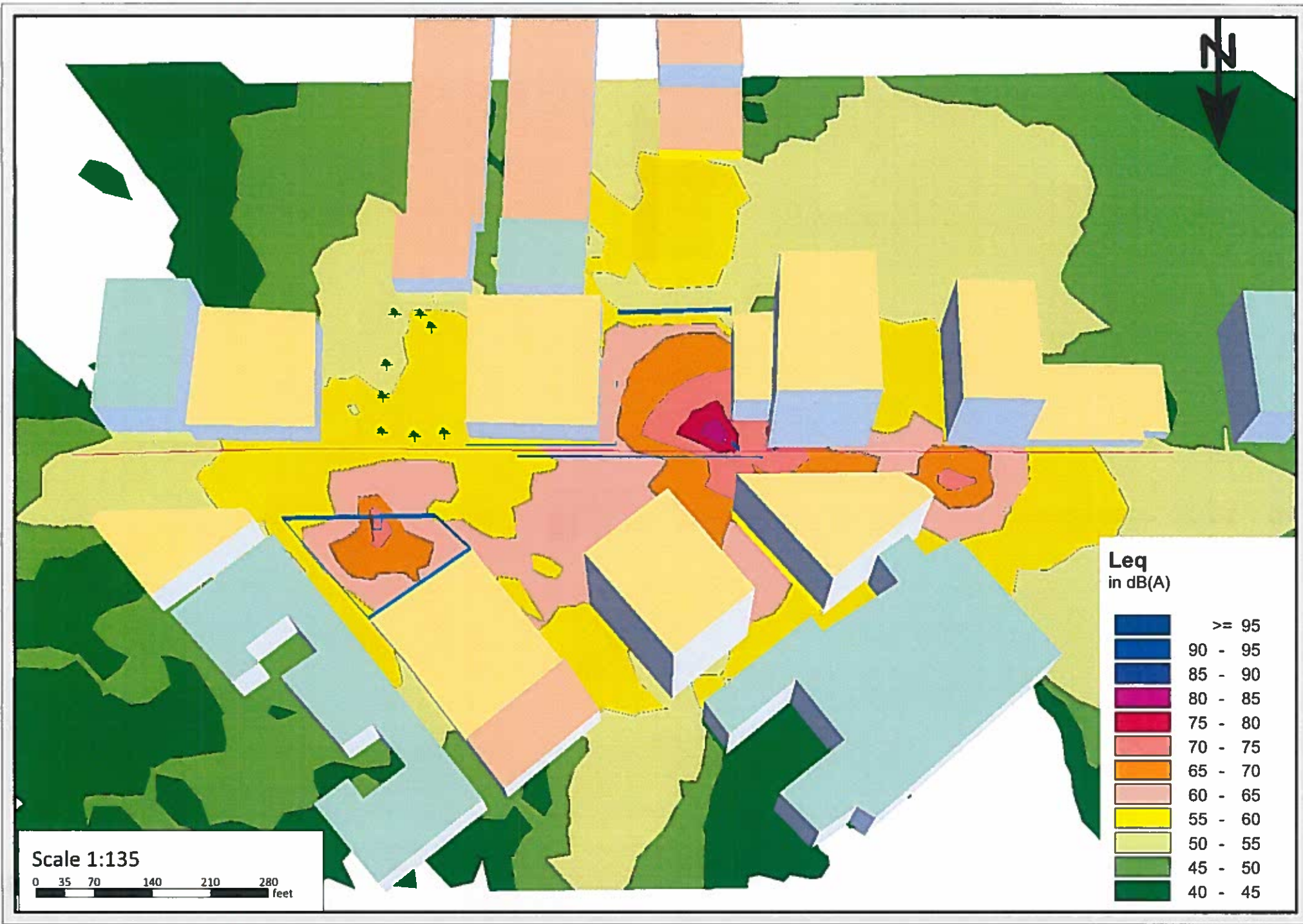

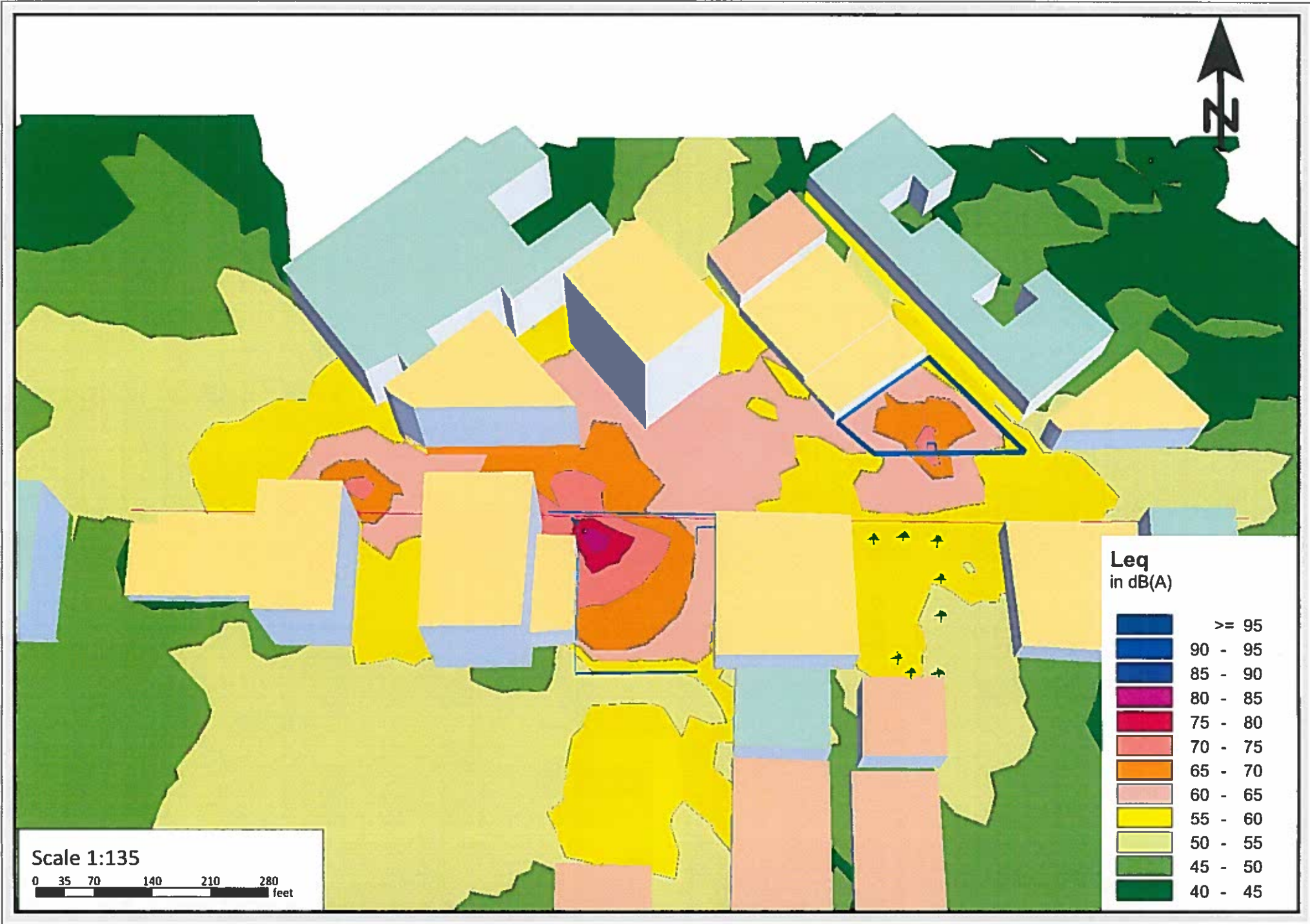

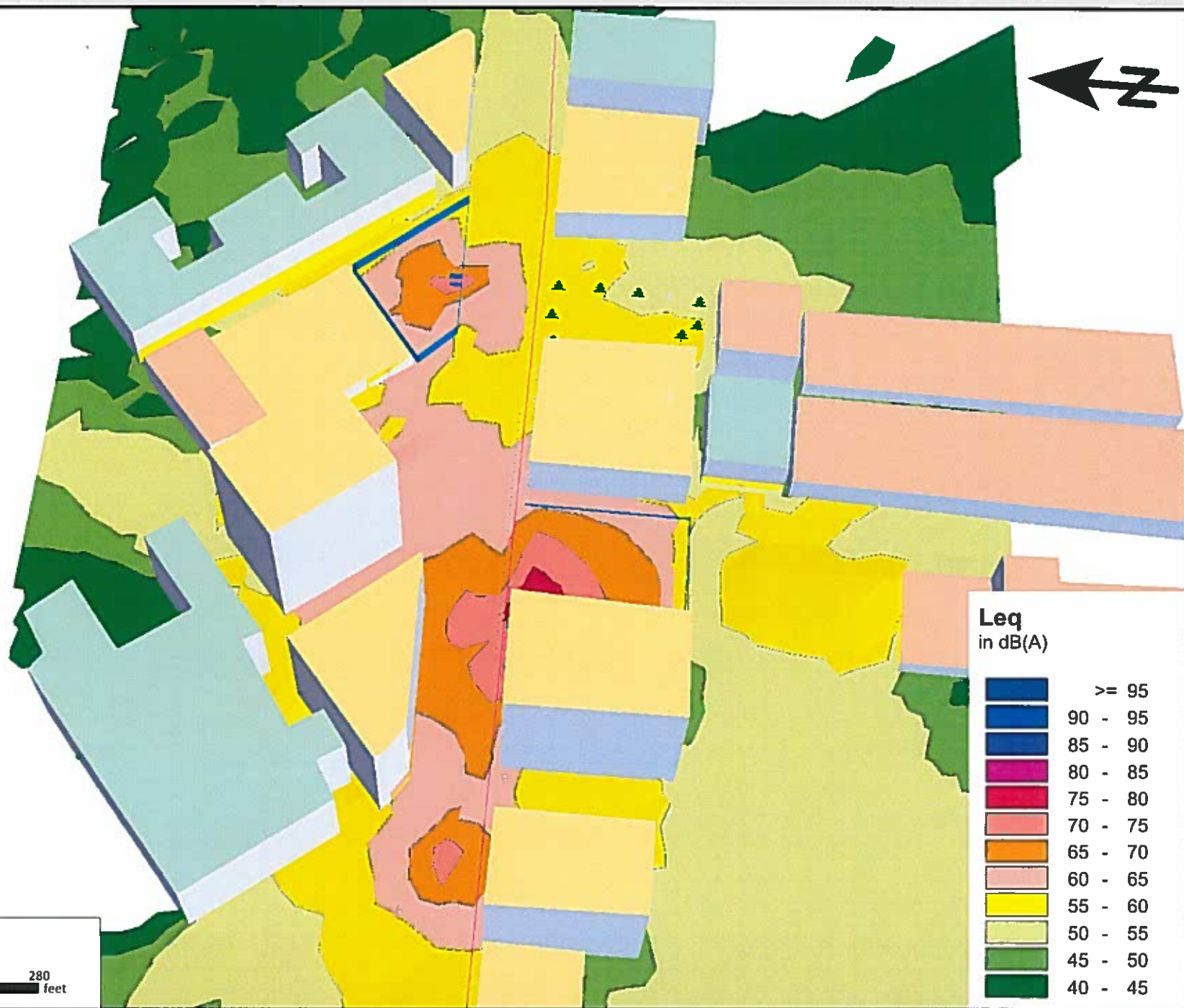

Scale 1:135

0 35 70 140 210 280 feet

## RD 1 Weekday

Time	Leq15 Threshold	Predicted	Exceedance (Yes/No)
12:00:00 AM	71	46	No
12:15:00 AM	70	46	No
12:30:00 AM	69	46	No
12:45:00 AM	69	46	No
1:00:00 AM	72	46	No
1:15:00 AM	68	46	No
1:30:00 AM	73	46	No
1:45:00 AM	70	46	No
2:00:00 AM	73	46	No
2:15:00 AM	67	46	No
2:30:00 AM	69	46	No
2:45:00 AM	68	46	No
3:00:00 AM	69	46	No
3:15:00 AM	70	46	No
3:30:00 AM	67	46	No
3:45:00 AM	67	46	No
4:00:00 AM	66	46	No
4:15:00 AM	70	46	No
4:30:00 AM	70	46	No
4:45:00 AM	71	46	No
5:00:00 AM	74	46	No
5:15:00 AM	74	46	No
5:30:00 AM	73	46	No
5:45:00 AM	72	46	No
6:00:00 AM	74	46	No
6:15:00 AM	76	46	No
6:30:00 AM	76	46	No
6:45:00 AM	76	46	No
7:00:00 AM	76	46	No
7:15:00 AM	75	46	No
7:30:00 AM	78	46	No
7:45:00 AM	76	46	No
8:00:00 AM	78	46	No
8:15:00 AM	77	46	No
8:30:00 AM	76	46	No
8:45:00 AM	76	46	No
9:00:00 AM	77	46	No
9:15:00 AM	86	46	No
9:30:00 AM	76	46	No
9:45:00 AM	76	46	No
10:00:00 AM	75	46	No
10:15:00 AM	76	46	No
10:30:00 AM	75	46	No
10:45:00 AM	74	46	No
11:00:00 AM	75	46	No
11:15:00 AM	75	46	No
11:30:00 AM	76	46	No
11:45:00 AM	75	46	No
12:00:00 PM	74	46	No
12:15:00 PM	75	46	No
12:30:00 PM	75	46	No
12:45:00 PM	75	46	No
1:00:00 PM	75	46	No
1:15:00 PM	77	46	No
1:30:00 PM	74	46	No
1:45:00 PM	83	46	No
2:00:00 PM	75	46	No
2:15:00 PM	74	46	No
2:30:00 PM	74	46	No

RD 1 Weekday			
Time	Leq15 Threshold	Predicted	Exceedance (Yes/No)
2:45:00 PM	74	46	No
3:00:00 PM	74	46	No
3:15:00 PM	75	46	No
3:30:00 PM	75	46	No
3:45:00 PM	74	46	No
4:00:00 PM	74	46	No
4:15:00 PM	75	46	No
4:30:00 PM	77	46	No
4:45:00 PM	75	46	No
5:00:00 PM	75	46	No
5:15:00 PM	81	46	No
5:30:00 PM	80	46	No
5:45:00 PM	80	46	No
6:00:00 PM	81	46	No
6:15:00 PM	74	46	No
6:30:00 PM	75	46	No
6:45:00 PM	81	46	No
7:00:00 PM	75	46	No
7:15:00 PM	77	46	No
7:30:00 PM	74	46	No
7:45:00 PM	74	46	No
8:00:00 PM	83	46	No
8:15:00 PM	75	46	No
8:30:00 PM	74	46	No
8:45:00 PM	75	46	No
9:00:00 PM	74	46	No
9:15:00 PM	75	46	No
9:30:00 PM	73	46	No
9:45:00 PM	75	46	No
10:00:00 PM	73	46	No
10:15:00 PM	73	46	No
10:30:00 PM	75	46	No
10:45:00 PM	72	46	No
11:00:00 PM	72	46	No
11:15:00 PM	73	46	No
11:30:00 PM	71	46	No
11:45:00 PM	71	46	No

RD1 Weekend			
Time	Leq15 Threshold	Predicted	Exceedance (Yes/No)
12:00:00 AM	71	46	No
12:15:00 AM	70	46	No
12:30:00 AM	71	46	No
12:45:00 AM	70	46	No
1:00:00 AM	69	46	No
1:15:00 AM	70	46	No
1:30:00 AM	69	46	No
1:45:00 AM	68	46	No
2:00:00 AM	68	46	No
2:15:00 AM	72	46	No
2:30:00 AM	68	46	No
2:45:00 AM	69	46	No
3:00:00 AM	76	46	No
3:15:00 AM	67	46	No
3:30:00 AM	76	46	No
3:45:00 AM	66	46	No
4:00:00 AM	65	46	No
4:15:00 AM	69	46	No
4:30:00 AM	67	46	No
4:45:00 AM	70	46	No
5:00:00 AM	66	46	No
5:15:00 AM	67	46	No
5:30:00 AM	66	46	No
5:45:00 AM	68	46	No
6:00:00 AM	70	46	No
6:15:00 AM	70	46	No
6:30:00 AM	70	46	No
6:45:00 AM	70	46	No
7:00:00 AM	70	46	No
7:15:00 AM	70	46	No
7:30:00 AM	71	46	No
7:45:00 AM	71	46	No
8:00:00 AM	71	46	No
8:15:00 AM	72	46	No
8:30:00 AM	71	46	No
8:45:00 AM	71	46	No
9:00:00 AM	72	46	No
9:15:00 AM	72	46	No
9:30:00 AM	72	46	No
9:45:00 AM	73	46	No
10:00:00 AM	72	46	No
10:15:00 AM	72	46	No
10:30:00 AM	74	46	No
10:45:00 AM	73	46	No
11:00:00 AM	74	46	No
11:15:00 AM	74	46	No
11:30:00 AM	73	46	No
11:45:00 AM	84	46	No
12:00:00 PM	73	46	No
12:15:00 PM	74	46	No
12:30:00 PM	73	46	No
12:45:00 PM	73	46	No
1:00:00 PM	73	46	No
1:15:00 PM	72	46	No
1:30:00 PM	74	46	No
1:45:00 PM	73	46	No
2:00:00 PM	72	46	No

RDI Weekend			
Time	Leq15 Threshold	Predicted	Exceedance (Yes/No)
2:15:00 PM	73	46	No
2:30:00 PM	73	46	No
2:45:00 PM	72	46	No
3:00:00 PM	82	46	No
3:15:00 PM	72	46	No
3:30:00 PM	72	46	No
3:45:00 PM	76	46	No
4:00:00 PM	78	46	No
4:15:00 PM	74	46	No
4:30:00 PM	73	46	No
4:45:00 PM	77	46	No
5:00:00 PM	73	46	No
5:15:00 PM	72	46	No
5:30:00 PM	72	46	No
5:45:00 PM	74	46	No
6:00:00 PM	73	46	No
6:15:00 PM	73	46	No
6:30:00 PM	76	46	No
6:45:00 PM	72	46	No
7:00:00 PM	74	46	No
7:15:00 PM	74	46	No
7:30:00 PM	74	46	No
7:45:00 PM	75	46	No
8:00:00 PM	74	46	No
8:15:00 PM	75	46	No
8:30:00 PM	76	46	No
8:45:00 PM	73	46	No
9:00:00 PM	75	46	No
9:15:00 PM	74	46	No
9:30:00 PM	75	46	No
9:45:00 PM	75	46	No
10:00:00 PM	72	46	No
10:15:00 PM	74	46	No
10:30:00 PM	73	46	No
10:45:00 PM	73	46	No
11:00:00 PM	72	46	No
11:15:00 PM	80	46	No
11:30:00 PM	75	46	No
11:45:00 PM	72	46	No



RD2 Weekdays			
Time	Leq15 Threshold	Predicted	Exceedance (Yes/No)
12:00:00 AM	74	60	No
12:15:00 AM	75	60	No
12:30:00 AM	73	60	No
12:45:00 AM	83	60	No
1:00:00 AM	73	60	No
1:15:00 AM	71	60	No
1:30:00 AM	79	60	No
1:45:00 AM	80	60	No
2:00:00 AM	71	60	No
2:15:00 AM	73	60	No
2:30:00 AM	71	60	No
2:45:00 AM	70	60	No
3:00:00 AM	76	60	No
3:15:00 AM	73	60	No
3:30:00 AM	69	60	No
3:45:00 AM	71	60	No
4:00:00 AM	71	60	No
4:15:00 AM	71	60	No
4:30:00 AM	75	60	No
4:45:00 AM	74	60	No
5:00:00 AM	75	60	No
5:15:00 AM	75	60	No
5:30:00 AM	76	60	No
5:45:00 AM	77	60	No
6:00:00 AM	77	60	No
6:15:00 AM	79	60	No
6:30:00 AM	83	60	No
6:45:00 AM	80	60	No
7:00:00 AM	83	60	No
7:15:00 AM	80	60	No
7:30:00 AM	81	60	No
7:45:00 AM	82	60	No
8:00:00 AM	82	60	No
8:15:00 AM	80	60	No
8:30:00 AM	80	60	No
8:45:00 AM	81	60	No
9:00:00 AM	80	60	No
9:15:00 AM	81	60	No
9:30:00 AM	80	60	No
9:45:00 AM	80	60	No
10:00:00 AM	82	60	No
10:15:00 AM	80	60	No
10:30:00 AM	80	60	No
10:45:00 AM	80	60	No
11:00:00 AM	80	60	No
11:15:00 AM	79	60	No
11:30:00 AM	78	60	No
11:45:00 AM	79	60	No
12:00:00 PM	84	60	No
12:15:00 PM	81	60	No
12:30:00 PM	80	60	No
12:45:00 PM	79	60	No
1:00:00 PM	81	60	No
1:15:00 PM	80	60	No
1:30:00 PM	79	60	No
1:45:00 PM	80	60	No

RD2 Weekdays			
Time	Leq15 Threshold	Predicted	Exceedance (Yes/No)
2:00:00 PM	81	60	No
2:15:00 PM	79	60	No
2:30:00 PM	80	60	No
2:45:00 PM	80	60	No
3:00:00 PM	79	60	No
3:15:00 PM	79	60	No
3:30:00 PM	80	60	No
3:45:00 PM	80	60	No
4:00:00 PM	80	60	No
4:15:00 PM	78	60	No
4:30:00 PM	77	60	No
4:45:00 PM	79	60	No
5:00:00 PM	80	60	No
5:15:00 PM	81	60	No
5:30:00 PM	80	60	No
5:45:00 PM	80	60	No
6:00:00 PM	79	60	No
6:15:00 PM	78	60	No
6:30:00 PM	79	60	No
6:45:00 PM	79	60	No
7:00:00 PM	80	60	No
7:15:00 PM	78	60	No
7:30:00 PM	78	60	No
7:45:00 PM	78	60	No
8:00:00 PM	78	60	No
8:15:00 PM	79	60	No
8:30:00 PM	77	60	No
8:45:00 PM	80	60	No
9:00:00 PM	77	60	No
9:15:00 PM	78	60	No
9:30:00 PM	78	60	No
9:45:00 PM	77	60	No
10:00:00 PM	83	60	No
10:15:00 PM	78	60	No
10:30:00 PM	80	60	No
10:45:00 PM	76	60	No
11:00:00 PM	80	60	No
11:15:00 PM	78	60	No
11:30:00 PM	74	60	No
11:45:00 PM	74	60	No

RD2 Weekends			
Time	Leq15 Threshold	Predicted	Exceedance (Yes/No)
12:00:00 AM	81	60	No
12:15:00 AM	73	60	No
12:30:00 AM	74	60	No
12:45:00 AM	72	60	No
1:00:00 AM	71	60	No
1:15:00 AM	72	60	No
1:30:00 AM	72	60	No
1:45:00 AM	71	60	No
2:00:00 AM	71	60	No
2:15:00 AM	76	60	No
2:30:00 AM	74	60	No
2:45:00 AM	80	60	No
3:00:00 AM	75	60	No
3:15:00 AM	70	60	No
3:30:00 AM	70	60	No
3:45:00 AM	69	60	No
4:00:00 AM	67	60	No
4:15:00 AM	69	60	No
4:30:00 AM	69	60	No
4:45:00 AM	72	60	No
5:00:00 AM	67	60	No
5:15:00 AM	66	60	No
5:30:00 AM	71	60	No
5:45:00 AM	72	60	No
6:00:00 AM	70	60	No
6:15:00 AM	70	60	No
6:30:00 AM	71	60	No
6:45:00 AM	73	60	No
7:00:00 AM	81	60	No
7:15:00 AM	73	60	No
7:30:00 AM	74	60	No
7:45:00 AM	74	60	No
8:00:00 AM	75	60	No
8:15:00 AM	76	60	No
8:30:00 AM	76	60	No
8:45:00 AM	75	60	No
9:00:00 AM	75	60	No
9:15:00 AM	76	60	No
9:30:00 AM	76	60	No
9:45:00 AM	77	60	No
10:00:00 AM	76	60	No
10:15:00 AM	80	60	No
10:30:00 AM	77	60	No
10:45:00 AM	76	60	No
11:00:00 AM	77	60	No
11:15:00 AM	77	60	No
11:30:00 AM	78	60	No
11:45:00 AM	80	60	No
12:00:00 PM	78	60	No
12:15:00 PM	77	60	No
12:30:00 PM	79	60	No
12:45:00 PM	79	60	No
1:00:00 PM	78	60	No
1:15:00 PM	77	60	No
1:30:00 PM	76	60	No
1:45:00 PM	77	60	No

RD2 Weekends			
Time	Leq15 Threshold	Predicted	Exceedance (Yes/No)
2:00:00 PM	77	60	No
2:15:00 PM	84	60	No
2:30:00 PM	78	60	No
2:45:00 PM	79	60	No
3:00:00 PM	85	60	No
3:15:00 PM	78	60	No
3:30:00 PM	77	60	No
3:45:00 PM	77	60	No
4:00:00 PM	81	60	No
4:15:00 PM	78	60	No
4:30:00 PM	79	60	No
4:45:00 PM	79	60	No
5:00:00 PM	79	60	No
5:15:00 PM	77	60	No
5:30:00 PM	77	60	No
5:45:00 PM	81	60	No
6:00:00 PM	77	60	No
6:15:00 PM	78	60	No
6:30:00 PM	76	60	No
6:45:00 PM	76	60	No
7:00:00 PM	78	60	No
7:15:00 PM	78	60	No
7:30:00 PM	84	60	No
7:45:00 PM	79	60	No
8:00:00 PM	80	60	No
8:15:00 PM	77	60	No
8:30:00 PM	80	60	No
8:45:00 PM	77	60	No
9:00:00 PM	78	60	No
9:15:00 PM	78	60	No
9:30:00 PM	83	60	No
9:45:00 PM	79	60	No
10:00:00 PM	77	60	No
10:15:00 PM	79	60	No
10:30:00 PM	77	60	No
10:45:00 PM	76	60	No
11:00:00 PM	76	60	No
11:15:00 PM	76	60	No
11:30:00 PM	76	60	No
11:45:00 PM	76	60	No

RD2 Elevated Receiver			
Time	Leq15 Threshold	Predicted	Exceedance (Yes/No)
12:00:00 AM	74	61	No
12:15:00 AM	74	61	No
12:30:00 AM	73	61	No
12:45:00 AM	83	61	No
1:00:00 AM	73	61	No
1:15:00 AM	71	61	No
1:30:00 AM	79	61	No
1:45:00 AM	80	61	No
2:00:00 AM	70	61	No
2:15:00 AM	72	61	No
2:30:00 AM	71	61	No
2:45:00 AM	70	61	No
3:00:00 AM	76	61	No
3:15:00 AM	72	61	No
3:30:00 AM	68	61	No
3:45:00 AM	70	61	No
4:00:00 AM	71	61	No
4:15:00 AM	71	61	No
4:30:00 AM	75	61	No
4:45:00 AM	74	61	No
5:00:00 AM	75	61	No
5:15:00 AM	75	61	No
5:30:00 AM	76	61	No
5:45:00 AM	77	61	No
6:00:00 AM	77	61	No
6:15:00 AM	79	61	No
6:30:00 AM	83	61	No
6:45:00 AM	80	61	No
7:00:00 AM	83	61	No
7:15:00 AM	80	61	No
7:30:00 AM	81	61	No
7:45:00 AM	81	61	No
8:00:00 AM	81	61	No
8:15:00 AM	80	61	No
8:30:00 AM	80	61	No
8:45:00 AM	80	61	No
9:00:00 AM	80	61	No
9:15:00 AM	80	61	No
9:30:00 AM	80	61	No
9:45:00 AM	80	61	No
10:00:00 AM	82	61	No
10:15:00 AM	79	61	No
10:30:00 AM	79	61	No
10:45:00 AM	79	61	No
11:00:00 AM	80	61	No
11:15:00 AM	79	61	No
11:30:00 AM	78	61	No
11:45:00 AM	79	61	No
12:00:00 PM	84	61	No
12:15:00 PM	81	61	No
12:30:00 PM	80	61	No
12:45:00 PM	78	61	No
1:00:00 PM	80	61	No
1:15:00 PM	80	61	No
1:30:00 PM	79	61	No
1:45:00 PM	79	61	No

RD2 Elevated Receiver			
Time	Leq15 Threshold	Predicted	Exceedance (Yes/No)
2:00:00 PM	81	61	No
2:15:00 PM	79	61	No
2:30:00 PM	80	61	No
2:45:00 PM	80	61	No
3:00:00 PM	79	61	No
3:15:00 PM	79	61	No
3:30:00 PM	79	61	No
3:45:00 PM	79	61	No
4:00:00 PM	80	61	No
4:15:00 PM	78	61	No
4:30:00 PM	77	61	No
4:45:00 PM	79	61	No
5:00:00 PM	80	61	No
5:15:00 PM	81	61	No
5:30:00 PM	80	61	No
5:45:00 PM	79	61	No
6:00:00 PM	79	61	No
6:15:00 PM	78	61	No
6:30:00 PM	79	61	No
6:45:00 PM	79	61	No
7:00:00 PM	79	61	No
7:15:00 PM	78	61	No
7:30:00 PM	78	61	No
7:45:00 PM	78	61	No
8:00:00 PM	78	61	No
8:15:00 PM	79	61	No
8:30:00 PM	77	61	No
8:45:00 PM	79	61	No
9:00:00 PM	77	61	No
9:15:00 PM	78	61	No
9:30:00 PM	77	61	No
9:45:00 PM	77	61	No
10:00:00 PM	82	61	No
10:15:00 PM	78	61	No
10:30:00 PM	80	61	No
10:45:00 PM	75	61	No
11:00:00 PM	80	61	No
11:15:00 PM	77	61	No
11:30:00 PM	74	61	No
11:45:00 PM	74	61	No

RD3 Weekdays			
Time	Leq15 Threshold	Predicted	Exceedance (Yes/No)
12:00:00 AM	75	56	No
12:15:00 AM	72	56	No
12:30:00 AM	73	56	No
12:45:00 AM	70	56	No
1:00:00 AM	72	56	No
1:15:00 AM	70	56	No
1:30:00 AM	75	56	No
1:45:00 AM	70	56	No
2:00:00 AM	73	56	No
2:15:00 AM	70	56	No
2:30:00 AM	76	56	No
2:45:00 AM	79	56	No
3:00:00 AM	77	56	No
3:15:00 AM	67	56	No
3:30:00 AM	72	56	No
3:45:00 AM	66	56	No
4:00:00 AM	66	56	No
4:15:00 AM	67	56	No
4:30:00 AM	69	56	No
4:45:00 AM	72	56	No
5:00:00 AM	74	56	No
5:15:00 AM	75	56	No
5:30:00 AM	77	56	No
5:45:00 AM	77	56	No
6:00:00 AM	78	56	No
6:15:00 AM	79	56	No
6:30:00 AM	79	56	No
6:45:00 AM	78	56	No
7:00:00 AM	79	56	No
7:15:00 AM	79	56	No
7:30:00 AM	79	56	No
7:45:00 AM	78	56	No
8:00:00 AM	78	56	No
8:15:00 AM	79	56	No
8:30:00 AM	78	56	No
8:45:00 AM	77	56	No
9:00:00 AM	80	56	No
9:15:00 AM	80	56	No
9:30:00 AM	78	56	No
9:45:00 AM	77	56	No
10:00:00 AM	78	56	No
10:15:00 AM	77	56	No
10:30:00 AM	77	56	No
10:45:00 AM	77	56	No
11:00:00 AM	78	56	No
11:15:00 AM	77	56	No
11:30:00 AM	85	56	No
11:45:00 AM	77	56	No
12:00:00 PM	78	56	No
12:15:00 PM	78	56	No
12:30:00 PM	78	56	No
12:45:00 PM	78	56	No
1:00:00 PM	78	56	No
1:15:00 PM	77	56	No
1:30:00 PM	79	56	No
1:45:00 PM	79	56	No
2:00:00 PM	78	56	No

RD3 Weekdays			
Time	Leq15 Threshold	Predicted	Exceedance (Yes/No)
2:15:00 PM	78	56	No
2:30:00 PM	78	56	No
2:45:00 PM	79	56	No
3:00:00 PM	78	56	No
3:15:00 PM	78	56	No
3:30:00 PM	80	56	No
3:45:00 PM	78	56	No
4:00:00 PM	78	56	No
4:15:00 PM	79	56	No
4:30:00 PM	79	56	No
4:45:00 PM	79	56	No
5:00:00 PM	80	56	No
5:15:00 PM	80	56	No
5:30:00 PM	81	56	No
5:45:00 PM	79	56	No
6:00:00 PM	81	56	No
6:15:00 PM	79	56	No
6:30:00 PM	78	56	No
6:45:00 PM	82	56	No
7:00:00 PM	78	56	No
7:15:00 PM	80	56	No
7:30:00 PM	80	56	No
7:45:00 PM	79	56	No
8:00:00 PM	82	56	No
8:15:00 PM	80	56	No
8:30:00 PM	79	56	No
8:45:00 PM	78	56	No
9:00:00 PM	81	56	No
9:15:00 PM	76	56	No
9:30:00 PM	78	56	No
9:45:00 PM	77	56	No
10:00:00 PM	76	56	No
10:15:00 PM	78	56	No
10:30:00 PM	79	56	No
10:45:00 PM	75	56	No
11:00:00 PM	76	56	No
11:15:00 PM	75	56	No
11:30:00 PM	74	56	No
11:45:00 PM	75	56	No



RD3 Weekend			
Time	Leq15 Threshold	Predicted	Exceedance (Yes/No)
12:00:00 AM	75	56	No
12:15:00 AM	74	56	No
12:30:00 AM	74	56	No
12:45:00 AM	72	56	No
1:00:00 AM	71	56	No
1:15:00 AM	67	56	No
1:30:00 AM	67	56	No
1:45:00 AM	67	56	No
2:00:00 AM	72	56	No
2:15:00 AM	70	56	No
2:30:00 AM	71	56	No
2:45:00 AM	75	56	No
3:00:00 AM	72	56	No
3:15:00 AM	61	56	No
3:30:00 AM	66	56	No
3:45:00 AM	64	56	No
4:00:00 AM	64	56	No
4:15:00 AM	60	56	No
4:30:00 AM	60	56	No
4:45:00 AM	63	56	No
5:00:00 AM	65	56	No
5:15:00 AM	65	56	No
5:30:00 AM	69	56	No
5:45:00 AM	69	56	No
6:00:00 AM	70	56	No
6:15:00 AM	71	56	No
6:30:00 AM	72	56	No
6:45:00 AM	71	56	No
7:00:00 AM	72	56	No
7:15:00 AM	71	56	No
7:30:00 AM	72	56	No
7:45:00 AM	70	56	No
8:00:00 AM	72	56	No
8:15:00 AM	72	56	No
8:30:00 AM	73	56	No
8:45:00 AM	73	56	No
9:00:00 AM	72	56	No
9:15:00 AM	72	56	No
9:30:00 AM	73	56	No
9:45:00 AM	73	56	No
10:00:00 AM	72	56	No
10:15:00 AM	74	56	No
10:30:00 AM	76	56	No
10:45:00 AM	73	56	No
11:00:00 AM	72	56	No
11:15:00 AM	78	56	No
11:30:00 AM	77	56	No
11:45:00 AM	78	56	No
12:00:00 PM	78	56	No
12:15:00 PM	77	56	No
12:30:00 PM	80	56	No
12:45:00 PM	78	56	No
1:00:00 PM	80	56	No
1:15:00 PM	76	56	No
1:30:00 PM	76	56	No
1:45:00 PM	76	56	No
2:00:00 PM	76	56	No

<b>RD3 Weekend</b>			
<b>Time</b>	<b>Lq15 Threshold</b>	<b>Predicted</b>	<b>Exceedance (Yes/No)</b>
2:15:00 PM	77	56	No
2:30:00 PM	78	56	No
2:45:00 PM	78	56	No
3:00:00 PM	78	56	No
3:15:00 PM	79	56	No
3:30:00 PM	77	56	No
3:45:00 PM	79	56	No
4:00:00 PM	81	56	No
4:15:00 PM	78	56	No
4:30:00 PM	78	56	No
4:45:00 PM	80	56	No
5:00:00 PM	81	56	No
5:15:00 PM	81	56	No
5:30:00 PM	79	56	No
5:45:00 PM	80	56	No
6:00:00 PM	79	56	No
6:15:00 PM	78	56	No
6:30:00 PM	79	56	No
6:45:00 PM	77	56	No
7:00:00 PM	78	56	No
7:15:00 PM	80	56	No
7:30:00 PM	79	56	No
7:45:00 PM	81	56	No
8:00:00 PM	78	56	No
8:15:00 PM	77	56	No
8:30:00 PM	83	56	No
8:45:00 PM	77	56	No
9:00:00 PM	77	56	No
9:15:00 PM	77	56	No
9:30:00 PM	80	56	No
9:45:00 PM	81	56	No
10:00:00 PM	77	56	No
10:15:00 PM	78	56	No
10:30:00 PM	76	56	No
10:45:00 PM	77	56	No
11:00:00 PM	78	56	No
11:15:00 PM	76	56	No
11:30:00 PM	76	56	No
11:45:00 PM	77	56	No

RD4 Weekdays			
Time	Leq15 Threshold	Predicted	Exceedance (Yes/No)
12:00:00 AM	79	66	No
12:15:00 AM	78	66	No
12:30:00 AM	75	66	No
12:45:00 AM	87	66	No
1:00:00 AM	75	66	No
1:15:00 AM	73	66	No
1:30:00 AM	85	66	No
1:45:00 AM	83	66	No
2:00:00 AM	73	66	No
2:15:00 AM	74	66	No
2:30:00 AM	74	66	No
2:45:00 AM	74	66	No
3:00:00 AM	78	66	No
3:15:00 AM	75	66	No
3:30:00 AM	72	66	No
3:45:00 AM	72	66	No
4:00:00 AM	73	66	No
4:15:00 AM	74	66	No
4:30:00 AM	76	66	No
4:45:00 AM	78	66	No
5:00:00 AM	77	66	No
5:15:00 AM	80	66	No
5:30:00 AM	80	66	No
5:45:00 AM	81	66	No
6:00:00 AM	81	66	No
6:15:00 AM	81	66	No
6:30:00 AM	82	66	No
6:45:00 AM	83	66	No
7:00:00 AM	82	66	No
7:15:00 AM	83	66	No
7:30:00 AM	84	66	No
7:45:00 AM	84	66	No
8:00:00 AM	83	66	No
8:15:00 AM	83	66	No
8:30:00 AM	83	66	No
8:45:00 AM	84	66	No
9:00:00 AM	83	66	No
9:15:00 AM	84	66	No
9:30:00 AM	83	66	No
9:45:00 AM	82	66	No
10:00:00 AM	86	66	No
10:15:00 AM	83	66	No
10:30:00 AM	82	66	No
10:45:00 AM	83	66	No
11:00:00 AM	81	66	No
11:15:00 AM	81	66	No
11:30:00 AM	82	66	No
11:45:00 AM	82	66	No
12:00:00 PM	85	66	No
12:15:00 PM	82	66	No
12:30:00 PM	81	66	No
12:45:00 PM	81	66	No
1:00:00 PM	83	66	No
1:15:00 PM	83	66	No
1:30:00 PM	82	66	No
1:45:00 PM	82	66	No
2:00:00 PM	83	66	No

RD4 Weekdays			
Time	Leq15 Threshold	Predicted	Exceedance (Yes/No)
2:15:00 PM	81	66	No
2:30:00 PM	83	66	No
2:45:00 PM	84	66	No
3:00:00 PM	82	66	No
3:15:00 PM	81	66	No
3:30:00 PM	83	66	No
3:45:00 PM	82	66	No
4:00:00 PM	83	66	No
4:15:00 PM	81	66	No
4:30:00 PM	81	66	No
4:45:00 PM	81	66	No
5:00:00 PM	82	66	No
5:15:00 PM	82	66	No
5:30:00 PM	81	66	No
5:45:00 PM	82	66	No
6:00:00 PM	83	66	No
6:15:00 PM	79	66	No
6:30:00 PM	80	66	No
6:45:00 PM	79	66	No
7:00:00 PM	81	66	No
7:15:00 PM	81	66	No
7:30:00 PM	80	66	No
7:45:00 PM	80	66	No
8:00:00 PM	80	66	No
8:15:00 PM	80	66	No
8:30:00 PM	80	66	No
8:45:00 PM	79	66	No
9:00:00 PM	79	66	No
9:15:00 PM	80	66	No
9:30:00 PM	82	66	No
9:45:00 PM	78	66	No
10:00:00 PM	88	66	No
10:15:00 PM	79	66	No
10:30:00 PM	84	66	No
10:45:00 PM	78	66	No
11:00:00 PM	78	66	No
11:15:00 PM	78	66	No
11:30:00 PM	77	66	No
11:45:00 PM	77	66	No

RD4 Weekends			
Time	Leq15 Threshold	Predicted	Exceedance (Yes/No)
12:00:00 AM	76	66	No
12:15:00 AM	77	66	No
12:30:00 AM	76	66	No
12:45:00 AM	75	66	No
1:00:00 AM	74	66	No
1:15:00 AM	74	66	No
1:30:00 AM	75	66	No
1:45:00 AM	73	66	No
2:00:00 AM	73	66	No
2:15:00 AM	76	66	No
2:30:00 AM	73	66	No
2:45:00 AM	74	66	No
3:00:00 AM	75	66	No
3:15:00 AM	75	66	No
3:30:00 AM	74	66	No
3:45:00 AM	71	66	No
4:00:00 AM	70	66	No
4:15:00 AM	70	66	No
4:30:00 AM	71	66	No
4:45:00 AM	74	66	No
5:00:00 AM	69	66	No
5:15:00 AM	69	66	No
5:30:00 AM	72	66	No
5:45:00 AM	72	66	No
6:00:00 AM	71	66	No
6:15:00 AM	73	66	No
6:30:00 AM	74	66	No
6:45:00 AM	75	66	No
7:00:00 AM	76	66	No
7:15:00 AM	76	66	No
7:30:00 AM	76	66	No
7:45:00 AM	76	66	No
8:00:00 AM	77	66	No
8:15:00 AM	77	66	No
8:30:00 AM	77	66	No
8:45:00 AM	77	66	No
9:00:00 AM	78	66	No
9:15:00 AM	77	66	No
9:30:00 AM	77	66	No
9:45:00 AM	79	66	No
10:00:00 AM	78	66	No
10:15:00 AM	78	66	No
10:30:00 AM	78	66	No
10:45:00 AM	78	66	No
11:00:00 AM	78	66	No
11:15:00 AM	78	66	No
11:30:00 AM	78	66	No
11:45:00 AM	83	66	No
12:00:00 PM	78	66	No
12:15:00 PM	78	66	No
12:30:00 PM	79	66	No
12:45:00 PM	79	66	No
1:00:00 PM	79	66	No
1:15:00 PM	78	66	No
1:30:00 PM	78	66	No
1:45:00 PM	78	66	No
2:00:00 PM	78	66	No

RD4 Weekends			
Time	Leq15 Threshold	Predicted	Exceedance (Yes/No)
2:15:00 PM	79	66	No
2:30:00 PM	78	66	No
2:45:00 PM	79	66	No
3:00:00 PM	81	66	No
3:15:00 PM	78	66	No
3:30:00 PM	78	66	No
3:45:00 PM	77	66	No
4:00:00 PM	83	66	No
4:15:00 PM	77	66	No
4:30:00 PM	79	66	No
4:45:00 PM	81	66	No
5:00:00 PM	78	66	No
5:15:00 PM	77	66	No
5:30:00 PM	78	66	No
5:45:00 PM	79	66	No
6:00:00 PM	77	66	No
6:15:00 PM	78	66	No
6:30:00 PM	77	66	No
6:45:00 PM	78	66	No
7:00:00 PM	79	66	No
7:15:00 PM	80	66	No
7:30:00 PM	80	66	No
7:45:00 PM	79	66	No
8:00:00 PM	79	66	No
8:15:00 PM	79	66	No
8:30:00 PM	79	66	No
8:45:00 PM	79	66	No
9:00:00 PM	79	66	No
9:15:00 PM	79	66	No
9:30:00 PM	78	66	No
9:45:00 PM	79	66	No
10:00:00 PM	78	66	No
10:15:00 PM	78	66	No
10:30:00 PM	78	66	No
10:45:00 PM	78	66	No
11:00:00 PM	77	66	No
11:15:00 PM	78	66	No
11:30:00 PM	78	66	No
11:45:00 PM	80	66	No

RD5 Weekdays			
Time	Leq15 Threshold	Predicted	Exceedance (Yes/No)
12:00:00 AM	61	55	No
12:15:00 AM	64	55	No
12:30:00 AM	60	55	No
12:45:00 AM	62	55	No
1:00:00 AM	60	55	No
1:15:00 AM	58	55	No
1:30:00 AM	58	55	No
1:45:00 AM	60	55	No
2:00:00 AM	58	55	No
2:15:00 AM	58	55	No
2:30:00 AM	59	55	No
2:45:00 AM	59	55	No
3:00:00 AM	57	55	No
3:15:00 AM	55	55	No
3:30:00 AM	55	55	No
3:45:00 AM	55	55	No
4:00:00 AM	55	55	No
4:15:00 AM	55	55	No
4:30:00 AM	56	55	No
4:45:00 AM	56	55	No
5:00:00 AM	56	55	No
5:15:00 AM	60	55	No
5:30:00 AM	59	55	No
5:45:00 AM	62	55	No
6:00:00 AM	60	55	No
6:15:00 AM	60	55	No
6:30:00 AM	63	55	No
6:45:00 AM	64	55	No
7:00:00 AM	62	55	No
7:15:00 AM	63	55	No
7:30:00 AM	63	55	No
7:45:00 AM	63	55	No
8:00:00 AM	66	55	No
8:15:00 AM	65	55	No
8:30:00 AM	69	55	No
8:45:00 AM	66	55	No
9:00:00 AM	69	55	No
9:15:00 AM	73	55	No
9:30:00 AM	67	55	No
9:45:00 AM	66	55	No
10:00:00 AM	68	55	No
10:15:00 AM	68	55	No
10:30:00 AM	66	55	No
10:45:00 AM	68	55	No
11:00:00 AM	66	55	No
11:15:00 AM	70	55	No
11:30:00 AM	68	55	No
11:45:00 AM	66	55	No
12:00:00 PM	66	55	No
12:15:00 PM	66	55	No
12:30:00 PM	68	55	No
12:45:00 PM	66	55	No
1:00:00 PM	66	55	No
1:15:00 PM	68	55	No
1:30:00 PM	68	55	No
1:45:00 PM	73	55	No
2:00:00 PM	67	55	No

RDS Weekdays			
Time	Leq15 Threshold	Predicted	Exceedance (Yes/No)
2:15:00 PM	67	55	No
2:30:00 PM	66	55	No
2:45:00 PM	67	55	No
3:00:00 PM	67	55	No
3:15:00 PM	66	55	No
3:30:00 PM	68	55	No
3:45:00 PM	68	55	No
4:00:00 PM	73	55	No
4:15:00 PM	72	55	No
4:30:00 PM	74	55	No
4:45:00 PM	74	55	No
5:00:00 PM	77	55	No
5:15:00 PM	70	55	No
5:30:00 PM	71	55	No
5:45:00 PM	67	55	No
6:00:00 PM	68	55	No
6:15:00 PM	68	55	No
6:30:00 PM	82	55	No
6:45:00 PM	72	55	No
7:00:00 PM	65	55	No
7:15:00 PM	65	55	No
7:30:00 PM	67	55	No
7:45:00 PM	65	55	No
8:00:00 PM	72	55	No
8:15:00 PM	67	55	No
8:30:00 PM	67	55	No
8:45:00 PM	66	55	No
9:00:00 PM	64	55	No
9:15:00 PM	64	55	No
9:30:00 PM	63	55	No
9:45:00 PM	64	55	No
10:00:00 PM	63	55	No
10:15:00 PM	64	55	No
10:30:00 PM	65	55	No
10:45:00 PM	62	55	No
11:00:00 PM	62	55	No
11:15:00 PM	62	55	No
11:30:00 PM	62	55	No
11:45:00 PM	63	55	No



RD5 Weekends			
Time	Leq15 Threshold	Predicted	Exceedance (Yes/No)
12:00:00 AM	62	55	No
12:15:00 AM	68	55	No
12:30:00 AM	63	55	No
12:45:00 AM	60	55	No
1:00:00 AM	60	55	No
1:15:00 AM	60	55	No
1:30:00 AM	60	55	No
1:45:00 AM	59	55	No
2:00:00 AM	59	55	No
2:15:00 AM	62	55	No
2:30:00 AM	59	55	No
2:45:00 AM	63	55	No
3:00:00 AM	60	55	No
3:15:00 AM	62	55	No
3:30:00 AM	59	55	No
3:45:00 AM	59	55	No
4:00:00 AM	58	55	No
4:15:00 AM	56	55	No
4:30:00 AM	57	55	No
4:45:00 AM	58	55	No
5:00:00 AM	57	55	No
5:15:00 AM	54	52* (see footnote)	No
5:30:00 AM	56	55	No
5:45:00 AM	57	55	No
6:00:00 AM	55	55	No
6:15:00 AM	57	55	No
6:30:00 AM	59	55	No
6:45:00 AM	61	55	No
7:00:00 AM	61	55	No
7:15:00 AM	61	55	No
7:30:00 AM	61	55	No
7:45:00 AM	62	55	No
8:00:00 AM	63	55	No
8:15:00 AM	64	55	No
8:30:00 AM	63	55	No
8:45:00 AM	62	55	No
9:00:00 AM	62	55	No
9:15:00 AM	62	55	No
9:30:00 AM	62	55	No
9:45:00 AM	64	55	No
10:00:00 AM	65	55	No
10:15:00 AM	64	55	No
10:30:00 AM	64	55	No
10:45:00 AM	64	55	No
11:00:00 AM	64	55	No
11:15:00 AM	64	55	No
11:30:00 AM	64	55	No
11:45:00 AM	69	55	No
12:00:00 PM	63	55	No
12:15:00 PM	66	55	No
12:30:00 PM	65	55	No
12:45:00 PM	66	55	No
1:00:00 PM	64	55	No
1:15:00 PM	64	55	No
1:30:00 PM	65	55	No
1:45:00 PM	64	55	No
2:00:00 PM	65	55	No

\* Predicted Noise per proposed modified equipment operation shown on page 9 of the report.

RDS Weekends			
Time	Leq15 Threshold	Predicted	Exceedance (Yes/No)
2:15:00 PM	64	55	No
2:30:00 PM	64	55	No
2:45:00 PM	65	55	No
3:00:00 PM	72	55	No
3:15:00 PM	64	55	No
3:30:00 PM	66	55	No
3:45:00 PM	64	55	No
4:00:00 PM	72	55	No
4:15:00 PM	64	55	No
4:30:00 PM	68	55	No
4:45:00 PM	70	55	No
5:00:00 PM	65	55	No
5:15:00 PM	65	55	No
5:30:00 PM	65	55	No
5:45:00 PM	65	55	No
6:00:00 PM	64	55	No
6:15:00 PM	64	55	No
6:30:00 PM	65	55	No
6:45:00 PM	65	55	No
7:00:00 PM	67	55	No
7:15:00 PM	65	55	No
7:30:00 PM	67	55	No
7:45:00 PM	65	55	No
8:00:00 PM	66	55	No
8:15:00 PM	65	55	No
8:30:00 PM	66	55	No
8:45:00 PM	64	55	No
9:00:00 PM	65	55	No
9:15:00 PM	65	55	No
9:30:00 PM	65	55	No
9:45:00 PM	64	55	No
10:00:00 PM	64	55	No
10:15:00 PM	65	55	No
10:30:00 PM	64	55	No
10:45:00 PM	63	55	No
11:00:00 PM	62	55	No
11:15:00 PM	63	55	No
11:30:00 PM	62	55	No
11:45:00 PM	64	55	No

RD6 Weekdays			
Time	Leq15 Threshold	Predicted	Exceedance (Yes/No)
12:00:00 AM	71	54	No
12:15:00 AM	72	54	No
12:30:00 AM	69	54	No
12:45:00 AM	71	54	No
1:00:00 AM	69	54	No
1:15:00 AM	66	54	No
1:30:00 AM	66	54	No
1:45:00 AM	66	54	No
2:00:00 AM	72	54	No
2:15:00 AM	69	54	No
2:30:00 AM	71	54	No
2:45:00 AM	62	54	No
3:00:00 AM	71	54	No
3:15:00 AM	64	54	No
3:30:00 AM	62	54	No
3:45:00 AM	70	54	No
4:00:00 AM	64	54	No
4:15:00 AM	68	54	No
4:30:00 AM	67	54	No
4:45:00 AM	68	54	No
5:00:00 AM	71	54	No
5:15:00 AM	72	54	No
5:30:00 AM	73	54	No
5:45:00 AM	71	54	No
6:00:00 AM	74	54	No
6:15:00 AM	76	54	No
6:30:00 AM	78	54	No
6:45:00 AM	75	54	No
7:00:00 AM	76	54	No
7:15:00 AM	81	54	No
7:30:00 AM	76	54	No
7:45:00 AM	76	54	No
8:00:00 AM	77	54	No
8:15:00 AM	75	54	No
8:30:00 AM	75	54	No
8:45:00 AM	80	54	No
9:00:00 AM	76	54	No
9:15:00 AM	79	54	No
9:30:00 AM	76	54	No
9:45:00 AM	75	54	No
10:00:00 AM	77	54	No
10:15:00 AM	75	54	No
10:30:00 AM	75	54	No
10:45:00 AM	75	54	No
11:00:00 AM	77	54	No
11:15:00 AM	76	54	No
11:30:00 AM	75	54	No
11:45:00 AM	76	54	No
12:00:00 PM	76	54	No
12:15:00 PM	76	54	No
12:30:00 PM	76	54	No
12:45:00 PM	77	54	No
1:00:00 PM	76	54	No
1:15:00 PM	76	54	No
1:30:00 PM	74	54	No
1:45:00 PM	77	54	No
2:00:00 PM	74	54	No

RD6 Weekdays			
Time	Leq15 Threshold	Predicted	Exceedance (Yes/No)
2:15:00 PM	75	54	No
2:30:00 PM	74	54	No
2:45:00 PM	75	54	No
3:00:00 PM	78	54	No
3:15:00 PM	75	54	No
3:30:00 PM	75	54	No
3:45:00 PM	75	54	No
4:00:00 PM	77	54	No
4:15:00 PM	76	54	No
4:30:00 PM	74	54	No
4:45:00 PM	76	54	No
5:00:00 PM	74	54	No
5:15:00 PM	76	54	No
5:30:00 PM	76	54	No
5:45:00 PM	77	54	No
6:00:00 PM	78	54	No
6:15:00 PM	76	54	No
6:30:00 PM	83	54	No
6:45:00 PM	78	54	No
7:00:00 PM	75	54	No
7:15:00 PM	75	54	No
7:30:00 PM	76	54	No
7:45:00 PM	77	54	No
8:00:00 PM	85	54	No
8:15:00 PM	75	54	No
8:30:00 PM	76	54	No
8:45:00 PM	76	54	No
9:00:00 PM	75	54	No
9:15:00 PM	76	54	No
9:30:00 PM	75	54	No
9:45:00 PM	80	54	No
10:00:00 PM	74	54	No
10:15:00 PM	75	54	No
10:30:00 PM	76	54	No
10:45:00 PM	74	54	No
11:00:00 PM	71	54	No
11:15:00 PM	73	54	No
11:30:00 PM	70	54	No
11:45:00 PM	76	54	No

RD6 Weekends			
Time	Leq15 Threshold	Predicted	Exceedance (Yes/No)
12:00:00 AM	70	54	No
12:15:00 AM	73	54	No
12:30:00 AM	74	54	No
12:45:00 AM	71	54	No
1:00:00 AM	68	54	No
1:15:00 AM	69	54	No
1:30:00 AM	77	54	No
1:45:00 AM	67	54	No
2:00:00 AM	74	54	No
2:15:00 AM	80	54	No
2:30:00 AM	72	54	No
2:45:00 AM	73	54	No
3:00:00 AM	78	54	No
3:15:00 AM	78	54	No
3:30:00 AM	73	54	No
3:45:00 AM	69	54	No
4:00:00 AM	75	54	No
4:15:00 AM	72	54	No
4:30:00 AM	72	54	No
4:45:00 AM	72	54	No
5:00:00 AM	62	54	No
5:15:00 AM	64	54	No
5:30:00 AM	66	54	No
5:45:00 AM	68	54	No
6:00:00 AM	64	54	No
6:15:00 AM	74	54	No
6:30:00 AM	68	54	No
6:45:00 AM	69	54	No
7:00:00 AM	69	54	No
7:15:00 AM	69	54	No
7:30:00 AM	71	54	No
7:45:00 AM	69	54	No
8:00:00 AM	73	54	No
8:15:00 AM	70	54	No
8:30:00 AM	73	54	No
8:45:00 AM	71	54	No
9:00:00 AM	71	54	No
9:15:00 AM	71	54	No
9:30:00 AM	72	54	No
9:45:00 AM	73	54	No
10:00:00 AM	73	54	No
10:15:00 AM	75	54	No
10:30:00 AM	74	54	No
10:45:00 AM	75	54	No
11:00:00 AM	71	54	No
11:15:00 AM	71	54	No
11:30:00 AM	72	54	No
11:45:00 AM	74	54	No
12:00:00 PM	74	54	No
12:15:00 PM	72	54	No
12:30:00 PM	73	54	No
12:45:00 PM	75	54	No
1:00:00 PM	74	54	No
1:15:00 PM	74	54	No
1:30:00 PM	74	54	No
1:45:00 PM	75	54	No
2:00:00 PM	75	54	No

RD6 Weekends			
Time	Leq15 Threshold	Predicted	Exceedance (Yes/No)
2:15:00 PM	74	54	No
2:30:00 PM	73	54	No
2:45:00 PM	72	54	No
3:00:00 PM	75	54	No
3:15:00 PM	74	54	No
3:30:00 PM	73	54	No
3:45:00 PM	72	54	No
4:00:00 PM	75	54	No
4:15:00 PM	76	54	No
4:30:00 PM	73	54	No
4:45:00 PM	74	54	No
5:00:00 PM	73	54	No
5:15:00 PM	74	54	No
5:30:00 PM	74	54	No
5:45:00 PM	73	54	No
6:00:00 PM	72	54	No
6:15:00 PM	73	54	No
6:30:00 PM	72	54	No
6:45:00 PM	75	54	No
7:00:00 PM	74	54	No
7:15:00 PM	74	54	No
7:30:00 PM	75	54	No
7:45:00 PM	74	54	No
8:00:00 PM	74	54	No
8:15:00 PM	75	54	No
8:30:00 PM	75	54	No
8:45:00 PM	76	54	No
9:00:00 PM	76	54	No
9:15:00 PM	76	54	No
9:30:00 PM	75	54	No
9:45:00 PM	75	54	No
10:00:00 PM	77	54	No
10:15:00 PM	76	54	No
10:30:00 PM	73	54	No
10:45:00 PM	75	54	No
11:00:00 PM	73	54	No
11:15:00 PM	75	54	No
11:30:00 PM	72	54	No
11:45:00 PM	73	54	No

RD7 Weekdays			
Time	Leq15 Threshold	Predicted	Exceedance (Yes/No)
12:00:00 AM	76	57	No
12:15:00 AM	80	57	No
12:30:00 AM	75	57	No
12:45:00 AM	75	57	No
1:00:00 AM	76	57	No
1:15:00 AM	73	57	No
1:30:00 AM	71	57	No
1:45:00 AM	79	57	No
2:00:00 AM	73	57	No
2:15:00 AM	73	57	No
2:30:00 AM	72	57	No
2:45:00 AM	69	57	No
3:00:00 AM	73	57	No
3:15:00 AM	69	57	No
3:30:00 AM	68	57	No
3:45:00 AM	73	57	No
4:00:00 AM	70	57	No
4:15:00 AM	72	57	No
4:30:00 AM	73	57	No
4:45:00 AM	74	57	No
5:00:00 AM	75	57	No
5:15:00 AM	75	57	No
5:30:00 AM	77	57	No
5:45:00 AM	77	57	No
6:00:00 AM	79	57	No
6:15:00 AM	79	57	No
6:30:00 AM	82	57	No
6:45:00 AM	83	57	No
7:00:00 AM	81	57	No
7:15:00 AM	83	57	No
7:30:00 AM	82	57	No
7:45:00 AM	82	57	No
8:00:00 AM	83	57	No
8:15:00 AM	83	57	No
8:30:00 AM	81	57	No
8:45:00 AM	81	57	No
9:00:00 AM	82	57	No
9:15:00 AM	92	57	No
9:30:00 AM	81	57	No
9:45:00 AM	81	57	No
10:00:00 AM	82	57	No
10:15:00 AM	82	57	No
10:30:00 AM	81	57	No
10:45:00 AM	81	57	No
11:00:00 AM	81	57	No
11:15:00 AM	81	57	No
11:30:00 AM	80	57	No
11:45:00 AM	81	57	No
12:00:00 PM	80	57	No
12:15:00 PM	82	57	No
12:30:00 PM	85	57	No
12:45:00 PM	80	57	No
1:00:00 PM	80	57	No
1:15:00 PM	81	57	No
1:30:00 PM	82	57	No
1:45:00 PM	89	57	No
2:00:00 PM	80	57	No

RD7 Weekdays			
Time	Leq15 Threshold	Predicted	Exceedance (Yes/No)
2:15:00 PM	80	57	No
2:30:00 PM	80	57	No
2:45:00 PM	81	57	No
3:00:00 PM	82	57	No
3:15:00 PM	81	57	No
3:30:00 PM	81	57	No
3:45:00 PM	81	57	No
4:00:00 PM	81	57	No
4:15:00 PM	81	57	No
4:30:00 PM	81	57	No
4:45:00 PM	82	57	No
5:00:00 PM	80	57	No
5:15:00 PM	85	57	No
5:30:00 PM	85	57	No
5:45:00 PM	86	57	No
6:00:00 PM	84	57	No
6:15:00 PM	81	57	No
6:30:00 PM	90	57	No
6:45:00 PM	88	57	No
7:00:00 PM	80	57	No
7:15:00 PM	81	57	No
7:30:00 PM	82	57	No
7:45:00 PM	81	57	No
8:00:00 PM	89	57	No
8:15:00 PM	80	57	No
8:30:00 PM	80	57	No
8:45:00 PM	80	57	No
9:00:00 PM	80	57	No
9:15:00 PM	80	57	No
9:30:00 PM	80	57	No
9:45:00 PM	81	57	No
10:00:00 PM	78	57	No
10:15:00 PM	79	57	No
10:30:00 PM	81	57	No
10:45:00 PM	77	57	No
11:00:00 PM	78	57	No
11:15:00 PM	79	57	No
11:30:00 PM	76	57	No
11:45:00 PM	78	57	No



RD7 Weekends			
Time	Leq15 Threshold	Predicted	Exceedance (Yes/No)
12:00:00 AM	76	57	No
12:15:00 AM	82	57	No
12:30:00 AM	77	57	No
12:45:00 AM	75	57	No
1:00:00 AM	75	57	No
1:15:00 AM	75	57	No
1:30:00 AM	74	57	No
1:45:00 AM	73	57	No
2:00:00 AM	73	57	No
2:15:00 AM	80	57	No
2:30:00 AM	72	57	No
2:45:00 AM	73	57	No
3:00:00 AM	75	57	No
3:15:00 AM	77	57	No
3:30:00 AM	75	57	No
3:45:00 AM	71	57	No
4:00:00 AM	72	57	No
4:15:00 AM	69	57	No
4:30:00 AM	71	57	No
4:45:00 AM	72	57	No
5:00:00 AM	69	57	No
5:15:00 AM	68	57	No
5:30:00 AM	71	57	No
5:45:00 AM	71	57	No
6:00:00 AM	70	57	No
6:15:00 AM	73	57	No
6:30:00 AM	74	57	No
6:45:00 AM	74	57	No
7:00:00 AM	75	57	No
7:15:00 AM	75	57	No
7:30:00 AM	76	57	No
7:45:00 AM	76	57	No
8:00:00 AM	77	57	No
8:15:00 AM	77	57	No
8:30:00 AM	77	57	No
8:45:00 AM	77	57	No
9:00:00 AM	78	57	No
9:15:00 AM	77	57	No
9:30:00 AM	77	57	No
9:45:00 AM	79	57	No
10:00:00 AM	77	57	No
10:15:00 AM	78	57	No
10:30:00 AM	78	57	No
10:45:00 AM	78	57	No
11:00:00 AM	78	57	No
11:15:00 AM	78	57	No
11:30:00 AM	78	57	No
11:45:00 AM	85	57	No
12:00:00 PM	78	57	No
12:15:00 PM	78	57	No
12:30:00 PM	80	57	No
12:45:00 PM	79	57	No
1:00:00 PM	79	57	No
1:15:00 PM	79	57	No
1:30:00 PM	79	57	No
1:45:00 PM	79	57	No
2:00:00 PM	79	57	No

RD7 Weekends			
Time	Leq15 Threshold	Predicted	Exceedance (Yes/No)
2:15:00 PM	78	57	No
2:30:00 PM	79	57	No
2:45:00 PM	78	57	No
3:00:00 PM	88	57	No
3:15:00 PM	78	57	No
3:30:00 PM	78	57	No
3:45:00 PM	78	57	No
4:00:00 PM	82	57	No
4:15:00 PM	78	57	No
4:30:00 PM	79	57	No
4:45:00 PM	82	57	No
5:00:00 PM	79	57	No
5:15:00 PM	78	57	No
5:30:00 PM	78	57	No
5:45:00 PM	79	57	No
6:00:00 PM	78	57	No
6:15:00 PM	78	57	No
6:30:00 PM	78	57	No
6:45:00 PM	77	57	No
7:00:00 PM	80	57	No
7:15:00 PM	80	57	No
7:30:00 PM	79	57	No
7:45:00 PM	80	57	No
8:00:00 PM	80	57	No
8:15:00 PM	80	57	No
8:30:00 PM	82	57	No
8:45:00 PM	79	57	No
9:00:00 PM	80	57	No
9:15:00 PM	79	57	No
9:30:00 PM	78	57	No
9:45:00 PM	80	57	No
10:00:00 PM	78	57	No
10:15:00 PM	79	57	No
10:30:00 PM	79	57	No
10:45:00 PM	79	57	No
11:00:00 PM	77	57	No
11:15:00 PM	77	57	No
11:30:00 PM	77	57	No
11:45:00 PM	82	57	No

RD8 Weekdays			
Time	Leq15 Threshold	Predicted	Exceedance (Yes/No)
12:00:00 AM	66	55	No
12:15:00 AM	70	55	No
12:30:00 AM	65	55	No
12:45:00 AM	65	55	No
1:00:00 AM	65	55	No
1:15:00 AM	62	55	No
1:30:00 AM	62	55	No
1:45:00 AM	64	55	No
2:00:00 AM	61	55	No
2:15:00 AM	62	55	No
2:30:00 AM	62	55	No
2:45:00 AM	61	55	No
3:00:00 AM	61	55	No
3:15:00 AM	60	55	No
3:30:00 AM	59	55	No
3:45:00 AM	62	55	No
4:00:00 AM	61	55	No
4:15:00 AM	62	55	No
4:30:00 AM	65	55	No
4:45:00 AM	64	55	No
5:00:00 AM	66	55	No
5:15:00 AM	66	55	No
5:30:00 AM	67	55	No
5:45:00 AM	67	55	No
6:00:00 AM	68	55	No
6:15:00 AM	69	55	No
6:30:00 AM	72	55	No
6:45:00 AM	73	55	No
7:00:00 AM	70	55	No
7:15:00 AM	80	55	No
7:30:00 AM	71	55	No
7:45:00 AM	72	55	No
8:00:00 AM	73	55	No
8:15:00 AM	73	55	No
8:30:00 AM	72	55	No
8:45:00 AM	72	55	No
9:00:00 AM	73	55	No
9:15:00 AM	79	55	No
9:30:00 AM	73	55	No
9:45:00 AM	71	55	No
10:00:00 AM	73	55	No
10:15:00 AM	74	55	No
10:30:00 AM	72	55	No
10:45:00 AM	71	55	No
11:00:00 AM	72	55	No
11:15:00 AM	73	55	No
11:30:00 AM	75	55	No
11:45:00 AM	72	55	No
12:00:00 PM	72	55	No
12:15:00 PM	73	55	No
12:30:00 PM	73	55	No
12:45:00 PM	73	55	No
1:00:00 PM	72	55	No
1:15:00 PM	72	55	No
1:30:00 PM	75	55	No
1:45:00 PM	78	55	No
2:00:00 PM	71	55	No

RD8 Weekdays			
Time	Leq15 Threshold	Predicted	Exceedance (Yes/No)
2:15:00 PM	71	55	No
2:30:00 PM	71	55	No
2:45:00 PM	71	55	No
3:00:00 PM	72	55	No
3:15:00 PM	73	55	No
3:30:00 PM	72	55	No
3:45:00 PM	71	55	No
4:00:00 PM	72	55	No
4:15:00 PM	71	55	No
4:30:00 PM	71	55	No
4:45:00 PM	72	55	No
5:00:00 PM	73	55	No
5:15:00 PM	74	55	No
5:30:00 PM	77	55	No
5:45:00 PM	74	55	No
6:00:00 PM	74	55	No
6:15:00 PM	71	55	No
6:30:00 PM	88	55	No
6:45:00 PM	78	55	No
7:00:00 PM	71	55	No
7:15:00 PM	71	55	No
7:30:00 PM	73	55	No
7:45:00 PM	71	55	No
8:00:00 PM	78	55	No
8:15:00 PM	70	55	No
8:30:00 PM	69	55	No
8:45:00 PM	70	55	No
9:00:00 PM	69	55	No
9:15:00 PM	69	55	No
9:30:00 PM	69	55	No
9:45:00 PM	70	55	No
10:00:00 PM	68	55	No
10:15:00 PM	68	55	No
10:30:00 PM	70	55	No
10:45:00 PM	67	55	No
11:00:00 PM	67	55	No
11:15:00 PM	69	55	No
11:30:00 PM	67	55	No
11:45:00 PM	69	55	No

RD8 Elevated Receiver			
Time	Leq15 Threshold	Predicted	Exceedance (Yes/No)
12:00:00 AM	66	59	No
12:15:00 AM	70	59	No
12:30:00 AM	66	59	No
12:45:00 AM	65	59	No
1:00:00 AM	65	59	No
1:15:00 AM	62	59	No
1:30:00 AM	62	59	No
1:45:00 AM	64	59	No
2:00:00 AM	62	59	No
2:15:00 AM	62	59	No
2:30:00 AM	62	59	No
2:45:00 AM	61	59	No
3:00:00 AM	61	59	No
3:15:00 AM	60	59	No
3:30:00 AM	59	59	No
3:45:00 AM	62	59	No
4:00:00 AM	62	59	No
4:15:00 AM	62	59	No
4:30:00 AM	65	59	No
4:45:00 AM	64	59	No
5:00:00 AM	66	59	No
5:15:00 AM	66	59	No
5:30:00 AM	67	59	No
5:45:00 AM	67	59	No
6:00:00 AM	68	59	No
6:15:00 AM	69	59	No
6:30:00 AM	72	59	No
6:45:00 AM	73	59	No
7:00:00 AM	71	59	No
7:15:00 AM	80	59	No
7:30:00 AM	71	59	No
7:45:00 AM	72	59	No
8:00:00 AM	73	59	No
8:15:00 AM	73	59	No
8:30:00 AM	72	59	No
8:45:00 AM	72	59	No
9:00:00 AM	73	59	No
9:15:00 AM	79	59	No
9:30:00 AM	73	59	No
9:45:00 AM	72	59	No
10:00:00 AM	73	59	No
10:15:00 AM	75	59	No
10:30:00 AM	72	59	No
10:45:00 AM	72	59	No
11:00:00 AM	73	59	No
11:15:00 AM	73	59	No
11:30:00 AM	75	59	No
11:45:00 AM	72	59	No
12:00:00 PM	72	59	No
12:15:00 PM	73	59	No
12:30:00 PM	73	59	No
12:45:00 PM	73	59	No
1:00:00 PM	72	59	No
1:15:00 PM	72	59	No
1:30:00 PM	75	59	No
1:45:00 PM	78	59	No
2:00:00 PM	71	59	No

<b>RD8 Elevated Receiver</b>			
<b>Time</b>	<b>Leq15 Threshold</b>	<b>Predicted</b>	<b>Exceedance (Yes/No)</b>
2:15:00 PM	72	59	No
2:30:00 PM	71	59	No
2:45:00 PM	71	59	No
3:00:00 PM	72	59	No
3:15:00 PM	74	59	No
3:30:00 PM	72	59	No
3:45:00 PM	72	59	No
4:00:00 PM	72	59	No
4:15:00 PM	71	59	No
4:30:00 PM	72	59	No
4:45:00 PM	72	59	No
5:00:00 PM	73	59	No
5:15:00 PM	74	59	No
5:30:00 PM	77	59	No
5:45:00 PM	74	59	No
6:00:00 PM	74	59	No
6:15:00 PM	71	59	No
6:30:00 PM	88	59	No
6:45:00 PM	78	59	No
7:00:00 PM	71	59	No
7:15:00 PM	72	59	No
7:30:00 PM	73	59	No
7:45:00 PM	71	59	No
8:00:00 PM	78	59	No
8:15:00 PM	70	59	No
8:30:00 PM	70	59	No
8:45:00 PM	71	59	No
9:00:00 PM	70	59	No
9:15:00 PM	69	59	No
9:30:00 PM	69	59	No
9:45:00 PM	70	59	No
10:00:00 PM	68	59	No
10:15:00 PM	69	59	No
10:30:00 PM	70	59	No
10:45:00 PM	67	59	No
11:00:00 PM	67	59	No
11:15:00 PM	69	59	No
11:30:00 PM	67	59	No
11:45:00 PM	70	59	No

RD8 Weekends			
Time	Leq15 Threshold	Predicted	Exceedance (Yes/No)
12:00:00 AM	66	55	No
12:15:00 AM	72	55	No
12:30:00 AM	67	55	No
12:45:00 AM	65	55	No
1:00:00 AM	64	55	No
1:15:00 AM	64	55	No
1:30:00 AM	65	55	No
1:45:00 AM	63	55	No
2:00:00 AM	63	55	No
2:15:00 AM	67	55	No
2:30:00 AM	63	55	No
2:45:00 AM	67	55	No
3:00:00 AM	65	55	No
3:15:00 AM	66	55	No
3:30:00 AM	64	55	No
3:45:00 AM	63	55	No
4:00:00 AM	62	55	No
4:15:00 AM	61	55	No
4:30:00 AM	61	55	No
4:45:00 AM	63	55	No
5:00:00 AM	61	55	No
5:15:00 AM	58	55	No
5:30:00 AM	61	55	No
5:45:00 AM	61	55	No
6:00:00 AM	60	55	No
6:15:00 AM	62	55	No
6:30:00 AM	64	55	No
6:45:00 AM	66	55	No
7:00:00 AM	65	55	No
7:15:00 AM	65	55	No
7:30:00 AM	65	55	No
7:45:00 AM	66	55	No
8:00:00 AM	68	55	No
8:15:00 AM	68	55	No
8:30:00 AM	68	55	No
8:45:00 AM	67	55	No
9:00:00 AM	67	55	No
9:15:00 AM	66	55	No
9:30:00 AM	67	55	No
9:45:00 AM	68	55	No
10:00:00 AM	69	55	No
10:15:00 AM	68	55	No
10:30:00 AM	69	55	No
10:45:00 AM	68	55	No
11:00:00 AM	68	55	No
11:15:00 AM	68	55	No
11:30:00 AM	68	55	No
11:45:00 AM	73	55	No
12:00:00 PM	68	55	No
12:15:00 PM	70	55	No
12:30:00 PM	69	55	No
12:45:00 PM	70	55	No
1:00:00 PM	69	55	No
1:15:00 PM	69	55	No
1:30:00 PM	69	55	No
1:45:00 PM	68	55	No
2:00:00 PM	70	55	No

RD8 Weekends			
Time	Leq15 Threshold	Predicted	Exceedance (Yes/No)
2:15:00 PM	69	55	No
2:30:00 PM	68	55	No
2:45:00 PM	69	55	No
3:00:00 PM	76	55	No
3:15:00 PM	69	55	No
3:30:00 PM	68	55	No
3:45:00 PM	68	55	No
4:00:00 PM	76	55	No
4:15:00 PM	68	55	No
4:30:00 PM	69	55	No
4:45:00 PM	75	55	No
5:00:00 PM	69	55	No
5:15:00 PM	68	55	No
5:30:00 PM	69	55	No
5:45:00 PM	69	55	No
6:00:00 PM	68	55	No
6:15:00 PM	69	55	No
6:30:00 PM	69	55	No
6:45:00 PM	68	55	No
7:00:00 PM	71	55	No
7:15:00 PM	70	55	No
7:30:00 PM	70	55	No
7:45:00 PM	70	55	No
8:00:00 PM	73	55	No
8:15:00 PM	70	55	No
8:30:00 PM	71	55	No
8:45:00 PM	69	55	No
9:00:00 PM	69	55	No
9:15:00 PM	69	55	No
9:30:00 PM	68	55	No
9:45:00 PM	69	55	No
10:00:00 PM	68	55	No
10:15:00 PM	69	55	No
10:30:00 PM	68	55	No
10:45:00 PM	68	55	No
11:00:00 PM	67	55	No
11:15:00 PM	67	55	No
11:30:00 PM	67	55	No
11:45:00 PM	68	55	No



<b>RD8 Weekends Elevated Receivers</b>			
<b>Time</b>	<b>Leq15 Threshold</b>	<b>Predicted</b>	<b>Exceedance (Yes/No)</b>
12:00:00 AM	67	59	No
12:15:00 AM	73	59	No
12:30:00 AM	67	59	No
12:45:00 AM	65	59	No
1:00:00 AM	65	59	No
1:15:00 AM	65	59	No
1:30:00 AM	65	59	No
1:45:00 AM	63	59	No
2:00:00 AM	64	59	No
2:15:00 AM	67	59	No
2:30:00 AM	64	59	No
2:45:00 AM	68	59	No
3:00:00 AM	65	59	No
3:15:00 AM	66	59	No
3:30:00 AM	64	59	No
3:45:00 AM	63	59	No
4:00:00 AM	62	59	No
4:15:00 AM	61	59	No
4:30:00 AM	62	59	No
4:45:00 AM	63	59	No
5:00:00 AM	61	59	No
5:15:00 AM	59	59	No
5:30:00 AM	61	59	No
5:45:00 AM	62	59	No
6:00:00 AM	60	59	No
6:15:00 AM	62	59	No
6:30:00 AM	64	59	No
6:45:00 AM	66	59	No
7:00:00 AM	66	59	No
7:15:00 AM	65	59	No
7:30:00 AM	66	59	No
7:45:00 AM	66	59	No
8:00:00 AM	68	59	No
8:15:00 AM	68	59	No
8:30:00 AM	68	59	No
8:45:00 AM	67	59	No
9:00:00 AM	67	59	No
9:15:00 AM	67	59	No
9:30:00 AM	67	59	No
9:45:00 AM	69	59	No
10:00:00 AM	69	59	No
10:15:00 AM	69	59	No
10:30:00 AM	69	59	No
10:45:00 AM	69	59	No
11:00:00 AM	68	59	No
11:15:00 AM	68	59	No
11:30:00 AM	68	59	No
11:45:00 AM	73	59	No
12:00:00 PM	68	59	No
12:15:00 PM	70	59	No
12:30:00 PM	70	59	No
12:45:00 PM	70	59	No
1:00:00 PM	69	59	No
1:15:00 PM	69	59	No
1:30:00 PM	70	59	No
1:45:00 PM	68	59	No
2:00:00 PM	70	59	No

RD8 Weekends Elevated Receivers			
Time	Leq15 Threshold	Predicted	Exceedance (Yes/No)
2:15:00 PM	68.8	59	No
2:30:00 PM	68.6	59	No
2:45:00 PM	69.2	59	No
3:00:00 PM	76.4	59	No
3:15:00 PM	68.9	59	No
3:30:00 PM	68	59	No
3:45:00 PM	68.3	59	No
4:00:00 PM	76.4	59	No
4:15:00 PM	68.3	59	No
4:30:00 PM	69.1	59	No
4:45:00 PM	75	59	No
5:00:00 PM	69.3	59	No
5:15:00 PM	68.1	59	No
5:30:00 PM	69.1	59	No
5:45:00 PM	69.1	59	No
6:00:00 PM	68.4	59	No
6:15:00 PM	68.8	59	No
6:30:00 PM	69	59	No
6:45:00 PM	68.2	59	No
7:00:00 PM	71	59	No
7:15:00 PM	70	59	No
7:30:00 PM	70.4	59	No
7:45:00 PM	70.1	59	No
8:00:00 PM	73	59	No
8:15:00 PM	69.8	59	No
8:30:00 PM	71.4	59	No
8:45:00 PM	69.2	59	No
9:00:00 PM	69.6	59	No
9:15:00 PM	69.6	59	No
9:30:00 PM	68.6	59	No
9:45:00 PM	69.2	59	No
10:00:00 PM	68.4	59	No
10:15:00 PM	69.5	59	No
10:30:00 PM	68.6	59	No
10:45:00 PM	68.6	59	No
11:00:00 PM	67.1	59	No
11:15:00 PM	67.5	59	No
11:30:00 PM	67.1	59	No
11:45:00 PM	68.6	59	No

RD10 Weekdays			
Time	Leq15 Threshold	Predicted	Exceedance (Yes/No)
12:00:00 AM	69	53	No
12:15:00 AM	68	53	No
12:30:00 AM	65	53	No
12:45:00 AM	65	53	No
1:00:00 AM	64	53	No
1:15:00 AM	67	53	No
1:30:00 AM	59	53	No
1:45:00 AM	63	53	No
2:00:00 AM	61	53	No
2:15:00 AM	60	53	No
2:30:00 AM	60	53	No
2:45:00 AM	58	53	No
3:00:00 AM	60	53	No
3:15:00 AM	57	53	No
3:30:00 AM	59	53	No
3:45:00 AM	61	53	No
4:00:00 AM	60	53	No
4:15:00 AM	61	53	No
4:30:00 AM	62	53	No
4:45:00 AM	63	53	No
5:00:00 AM	63	53	No
5:15:00 AM	63	53	No
5:30:00 AM	64	53	No
5:45:00 AM	66	53	No
6:00:00 AM	66	53	No
6:15:00 AM	67	53	No
6:30:00 AM	69	53	No
6:45:00 AM	71	53	No
7:00:00 AM	70	53	No
7:15:00 AM	72	53	No
7:30:00 AM	73	53	No
7:45:00 AM	71	53	No
8:00:00 AM	72	53	No
8:15:00 AM	73	53	No
8:30:00 AM	71	53	No
8:45:00 AM	71	53	No
9:00:00 AM	71	53	No
9:15:00 AM	78	53	No
9:30:00 AM	72	53	No
9:45:00 AM	73	53	No
10:00:00 AM	73	53	No
10:15:00 AM	73	53	No
10:30:00 AM	74	53	No
10:45:00 AM	74	53	No
11:00:00 AM	74	53	No
11:15:00 AM	73	53	No
11:30:00 AM	75	53	No
11:45:00 AM	72	53	No
12:00:00 PM	72	53	No
12:15:00 PM	72	53	No
12:30:00 PM	85	53	No
12:45:00 PM	73	53	No
1:00:00 PM	73	53	No
1:15:00 PM	72	53	No
1:30:00 PM	72	53	No
1:45:00 PM	75	53	No
2:00:00 PM	72	53	No

RD10 Weekdays			
Time	Leq15 Threshold	Predicted	Exceedance (Yes/No)
2:15:00 PM	74	53	No
2:30:00 PM	74	53	No
2:45:00 PM	74	53	No
3:00:00 PM	73	53	No
3:15:00 PM	71	53	No
3:30:00 PM	74	53	No
3:45:00 PM	72	53	No
4:00:00 PM	72	53	No
4:15:00 PM	72	53	No
4:30:00 PM	74	53	No
4:45:00 PM	72	53	No
5:00:00 PM	72	53	No
5:15:00 PM	74	53	No
5:30:00 PM	75	53	No
5:45:00 PM	74	53	No
6:00:00 PM	75	53	No
6:15:00 PM	71	53	No
6:30:00 PM	86	53	No
6:45:00 PM	76	53	No
7:00:00 PM	73	53	No
7:15:00 PM	72	53	No
7:30:00 PM	71	53	No
7:45:00 PM	71	53	No
8:00:00 PM	74	53	No
8:15:00 PM	69	53	No
8:30:00 PM	69	53	No
8:45:00 PM	68	53	No
9:00:00 PM	70	53	No
9:15:00 PM	69	53	No
9:30:00 PM	70	53	No
9:45:00 PM	69	53	No
10:00:00 PM	68	53	No
10:15:00 PM	68	53	No
10:30:00 PM	70	53	No
10:45:00 PM	69	53	No
11:00:00 PM	67	53	No
11:15:00 PM	69	53	No
11:30:00 PM	66	53	No
11:45:00 PM	65	53	No

RD10 Weekends			
Time	Leq15 Threshold	Predicted	Exceedance (Yes/No)
12:00:00 AM	65	53	No
12:15:00 AM	65	53	No
12:30:00 AM	65	53	No
12:45:00 AM	64	53	No
1:00:00 AM	63	53	No
1:15:00 AM	66	53	No
1:30:00 AM	64	53	No
1:45:00 AM	63	53	No
2:00:00 AM	64	53	No
2:15:00 AM	76	53	No
2:30:00 AM	62	53	No
2:45:00 AM	64	53	No
3:00:00 AM	66	53	No
3:15:00 AM	64	53	No
3:30:00 AM	66	53	No
3:45:00 AM	62	53	No
4:00:00 AM	63	53	No
4:15:00 AM	61	53	No
4:30:00 AM	61	53	No
4:45:00 AM	63	53	No
5:00:00 AM	57	53	No
5:15:00 AM	57	53	No
5:30:00 AM	58	53	No
5:45:00 AM	58	53	No
6:00:00 AM	58	53	No
6:15:00 AM	60	53	No
6:30:00 AM	62	53	No
6:45:00 AM	62	53	No
7:00:00 AM	63	53	No
7:15:00 AM	63	53	No
7:30:00 AM	63	53	No
7:45:00 AM	64	53	No
8:00:00 AM	67	53	No
8:15:00 AM	68	53	No
8:30:00 AM	68	53	No
8:45:00 AM	66	53	No
9:00:00 AM	68	53	No
9:15:00 AM	65	53	No
9:30:00 AM	66	53	No
9:45:00 AM	67	53	No
10:00:00 AM	67	53	No
10:15:00 AM	67	53	No
10:30:00 AM	67	53	No
10:45:00 AM	67	53	No
11:00:00 AM	69	53	No
11:15:00 AM	67	53	No
11:30:00 AM	68	53	No
11:45:00 AM	70	53	No
12:00:00 PM	68	53	No
12:15:00 PM	68	53	No
12:30:00 PM	70	53	No
12:45:00 PM	70	53	No
1:00:00 PM	71	53	No
1:15:00 PM	70	53	No
1:30:00 PM	68	53	No
1:45:00 PM	69	53	No
2:00:00 PM	69	53	No

<b>RD10 Weekends</b>			
<b>Time</b>	<b>Leq15 Threshold</b>	<b>Predicted</b>	<b>Exceedance (Yes/No)</b>
2:15:00 PM	69	53	No
2:30:00 PM	68	53	No
2:45:00 PM	70	53	No
3:00:00 PM	69	53	No
3:15:00 PM	68	53	No
3:30:00 PM	69	53	No
3:45:00 PM	68	53	No
4:00:00 PM	69	53	No
4:15:00 PM	68	53	No
4:30:00 PM	69	53	No
4:45:00 PM	75	53	No
5:00:00 PM	68	53	No
5:15:00 PM	69	53	No
5:30:00 PM	68	53	No
5:45:00 PM	68	53	No
6:00:00 PM	67	53	No
6:15:00 PM	68	53	No
6:30:00 PM	67	53	No
6:45:00 PM	67	53	No
7:00:00 PM	69	53	No
7:15:00 PM	69	53	No
7:30:00 PM	71	53	No
7:45:00 PM	69	53	No
8:00:00 PM	69	53	No
8:15:00 PM	68	53	No
8:30:00 PM	68	53	No
8:45:00 PM	75	53	No
9:00:00 PM	69	53	No
9:15:00 PM	68	53	No
9:30:00 PM	68	53	No
9:45:00 PM	71	53	No
10:00:00 PM	68	53	No
10:15:00 PM	70	53	No
10:30:00 PM	68	53	No
10:45:00 PM	68	53	No
11:00:00 PM	66	53	No
11:15:00 PM	66	53	No
11:30:00 PM	66	53	No
11:45:00 PM	67	53	No

RD11 Weekdays			
Time	Leq15 Threshold	Predicted	Exceedance (Yes/No)
12:00:00 AM	77	52	No
12:15:00 AM	78	52	No
12:30:00 AM	75	52	No
12:45:00 AM	74	52	No
1:00:00 AM	76	52	No
1:15:00 AM	74	52	No
1:30:00 AM	73	52	No
1:45:00 AM	77	52	No
2:00:00 AM	73	52	No
2:15:00 AM	73	52	No
2:30:00 AM	74	52	No
2:45:00 AM	72	52	No
3:00:00 AM	72	52	No
3:15:00 AM	71	52	No
3:30:00 AM	69	52	No
3:45:00 AM	75	52	No
4:00:00 AM	70	52	No
4:15:00 AM	72	52	No
4:30:00 AM	74	52	No
4:45:00 AM	75	52	No
5:00:00 AM	75	52	No
5:15:00 AM	77	52	No
5:30:00 AM	77	52	No
5:45:00 AM	78	52	No
6:00:00 AM	79	52	No
6:15:00 AM	79	52	No
6:30:00 AM	80	52	No
6:45:00 AM	81	52	No
7:00:00 AM	82	52	No
7:15:00 AM	82	52	No
7:30:00 AM	82	52	No
7:45:00 AM	82	52	No
8:00:00 AM	82	52	No
8:15:00 AM	82	52	No
8:30:00 AM	81	52	No
8:45:00 AM	81	52	No
9:00:00 AM	81	52	No
9:15:00 AM	91	52	No
9:30:00 AM	81	52	No
9:45:00 AM	81	52	No
10:00:00 AM	81	52	No
10:15:00 AM	81	52	No
10:30:00 AM	80	52	No
10:45:00 AM	80	52	No
11:00:00 AM	81	52	No
11:15:00 AM	80	52	No
11:30:00 AM	80	52	No
11:45:00 AM	81	52	No
12:00:00 PM	79	52	No
12:15:00 PM	81	52	No
12:30:00 PM	81	52	No
12:45:00 PM	81	52	No
1:00:00 PM	80	52	No
1:15:00 PM	81	52	No
1:30:00 PM	86	52	No
1:45:00 PM	87	52	No
2:00:00 PM	81	52	No

RD11 Weekdays			
Time	Leq15 Threshold	Predicted	Exceedance (Yes/No)
2:15:00 PM	80	52	No
2:30:00 PM	79	52	No
2:45:00 PM	81	52	No
3:00:00 PM	81	52	No
3:15:00 PM	81	52	No
3:30:00 PM	80	52	No
3:45:00 PM	81	52	No
4:00:00 PM	81	52	No
4:15:00 PM	81	52	No
4:30:00 PM	81	52	No
4:45:00 PM	82	52	No
5:00:00 PM	80	52	No
5:15:00 PM	87	52	No
5:30:00 PM	85	52	No
5:45:00 PM	84	52	No
6:00:00 PM	87	52	No
6:15:00 PM	80	52	No
6:30:00 PM	91	52	No
6:45:00 PM	89	52	No
7:00:00 PM	84	52	No
7:15:00 PM	81	52	No
7:30:00 PM	81	52	No
7:45:00 PM	80	52	No
8:00:00 PM	83	52	No
8:15:00 PM	80	52	No
8:30:00 PM	80	52	No
8:45:00 PM	80	52	No
9:00:00 PM	81	52	No
9:15:00 PM	80	52	No
9:30:00 PM	79	52	No
9:45:00 PM	79	52	No
10:00:00 PM	78	52	No
10:15:00 PM	78	52	No
10:30:00 PM	81	52	No
10:45:00 PM	78	52	No
11:00:00 PM	78	52	No
11:15:00 PM	79	52	No
11:30:00 PM	77	52	No
11:45:00 PM	78	52	No



RD11 Elevated Receivers			
Time	Leq15 Threshold	Predicted	Exceedance (Yes/No)
12:00:00 AM	75	52	No
12:15:00 AM	76	52	No
12:30:00 AM	73	52	No
12:45:00 AM	72	52	No
1:00:00 AM	74	52	No
1:15:00 AM	72	52	No
1:30:00 AM	71	52	No
1:45:00 AM	75	52	No
2:00:00 AM	71	52	No
2:15:00 AM	71	52	No
2:30:00 AM	72	52	No
2:45:00 AM	70	52	No
3:00:00 AM	70	52	No
3:15:00 AM	69	52	No
3:30:00 AM	67	52	No
3:45:00 AM	73	52	No
4:00:00 AM	68	52	No
4:15:00 AM	70	52	No
4:30:00 AM	72	52	No
4:45:00 AM	73	52	No
5:00:00 AM	73	52	No
5:15:00 AM	75	52	No
5:30:00 AM	75	52	No
5:45:00 AM	76	52	No
6:00:00 AM	77	52	No
6:15:00 AM	77	52	No
6:30:00 AM	78	52	No
6:45:00 AM	79	52	No
7:00:00 AM	80	52	No
7:15:00 AM	80	52	No
7:30:00 AM	80	52	No
7:45:00 AM	80	52	No
8:00:00 AM	80	52	No
8:15:00 AM	80	52	No
8:30:00 AM	79	52	No
8:45:00 AM	79	52	No
9:00:00 AM	79	52	No
9:15:00 AM	89	52	No
9:30:00 AM	79	52	No
9:45:00 AM	79	52	No
10:00:00 AM	79	52	No
10:15:00 AM	79	52	No
10:30:00 AM	78	52	No
10:45:00 AM	78	52	No
11:00:00 AM	79	52	No
11:15:00 AM	78	52	No
11:30:00 AM	78	52	No
11:45:00 AM	79	52	No
12:00:00 PM	77	52	No
12:15:00 PM	79	52	No
12:30:00 PM	79	52	No
12:45:00 PM	79	52	No
1:00:00 PM	78	52	No
1:15:00 PM	79	52	No
1:30:00 PM	84	52	No
1:45:00 PM	85	52	No
2:00:00 PM	79	52	No

<b>RD11 Elevated Receivers</b>			
<b>Time</b>	<b>Leq15 Threshold</b>	<b>Predicted</b>	<b>Exceedance (Yes/No)</b>
2:15:00 PM	78	52	No
2:30:00 PM	77	52	No
2:45:00 PM	79	52	No
3:00:00 PM	79	52	No
3:15:00 PM	79	52	No
3:30:00 PM	78	52	No
3:45:00 PM	79	52	No
4:00:00 PM	79	52	No
4:15:00 PM	79	52	No
4:30:00 PM	79	52	No
4:45:00 PM	80	52	No
5:00:00 PM	78	52	No
5:15:00 PM	85	52	No
5:30:00 PM	83	52	No
5:45:00 PM	82	52	No
6:00:00 PM	85	52	No
6:15:00 PM	78	52	No
6:30:00 PM	89	52	No
6:45:00 PM	87	52	No
7:00:00 PM	82	52	No
7:15:00 PM	79	52	No
7:30:00 PM	79	52	No
7:45:00 PM	78	52	No
8:00:00 PM	81	52	No
8:15:00 PM	78	52	No
8:30:00 PM	78	52	No
8:45:00 PM	78	52	No
9:00:00 PM	79	52	No
9:15:00 PM	78	52	No
9:30:00 PM	77	52	No
9:45:00 PM	77	52	No
10:00:00 PM	76	52	No
10:15:00 PM	76	52	No
10:30:00 PM	79	52	No
10:45:00 PM	76	52	No
11:00:00 PM	76	52	No
11:15:00 PM	77	52	No
11:30:00 PM	75	52	No
11:45:00 PM	76	52	No

RD11 Weekends			
Time	Leq15 Threshold	Predicted	Exceedance (Yes/No)
12:00:00 AM	77	52	No
12:15:00 AM	76	52	No
12:30:00 AM	78	52	No
12:45:00 AM	76	52	No
1:00:00 AM	75	52	No
1:15:00 AM	75	52	No
1:30:00 AM	76	52	No
1:45:00 AM	74	52	No
2:00:00 AM	75	52	No
2:15:00 AM	78	52	No
2:30:00 AM	75	52	No
2:45:00 AM	75	52	No
3:00:00 AM	78	52	No
3:15:00 AM	75	52	No
3:30:00 AM	77	52	No
3:45:00 AM	72	52	No
4:00:00 AM	76	52	No
4:15:00 AM	72	52	No
4:30:00 AM	74	52	No
4:45:00 AM	76	52	No
5:00:00 AM	71	52	No
5:15:00 AM	70	52	No
5:30:00 AM	73	52	No
5:45:00 AM	71	52	No
6:00:00 AM	73	52	No
6:15:00 AM	74	52	No
6:30:00 AM	75	52	No
6:45:00 AM	74	52	No
7:00:00 AM	76	52	No
7:15:00 AM	76	52	No
7:30:00 AM	76	52	No
7:45:00 AM	76	52	No
8:00:00 AM	77	52	No
8:15:00 AM	83	52	No
8:30:00 AM	77	52	No
8:45:00 AM	77	52	No
9:00:00 AM	78	52	No
9:15:00 AM	77	52	No
9:30:00 AM	78	52	No
9:45:00 AM	79	52	No
10:00:00 AM	77	52	No
10:15:00 AM	78	52	No
10:30:00 AM	78	52	No
10:45:00 AM	81	52	No
11:00:00 AM	78	52	No
11:15:00 AM	78	52	No
11:30:00 AM	78	52	No
11:45:00 AM	86	52	No
12:00:00 PM	78	52	No
12:15:00 PM	79	52	No
12:30:00 PM	80	52	No
12:45:00 PM	80	52	No
1:00:00 PM	79	52	No
1:15:00 PM	79	52	No
1:30:00 PM	79	52	No
1:45:00 PM	79	52	No
2:00:00 PM	78	52	No

RD11 Weekends			
Time	Leq15 Threshold	Predicted	Exceedance (Yes/No)
2:15:00 PM	80	52	No
2:30:00 PM	79	52	No
2:45:00 PM	78	52	No
3:00:00 PM	79	52	No
3:15:00 PM	78	52	No
3:30:00 PM	78	52	No
3:45:00 PM	78	52	No
4:00:00 PM	82	52	No
4:15:00 PM	78	52	No
4:30:00 PM	78	52	No
4:45:00 PM	82	52	No
5:00:00 PM	79	52	No
5:15:00 PM	78	52	No
5:30:00 PM	78	52	No
5:45:00 PM	82	52	No
6:00:00 PM	78	52	No
6:15:00 PM	79	52	No
6:30:00 PM	79	52	No
6:45:00 PM	78	52	No
7:00:00 PM	80	52	No
7:15:00 PM	79	52	No
7:30:00 PM	80	52	No
7:45:00 PM	80	52	No
8:00:00 PM	80	52	No
8:15:00 PM	80	52	No
8:30:00 PM	79	52	No
8:45:00 PM	79	52	No
9:00:00 PM	82	52	No
9:15:00 PM	79	52	No
9:30:00 PM	78	52	No
9:45:00 PM	80	52	No
10:00:00 PM	78	52	No
10:15:00 PM	80	52	No
10:30:00 PM	79	52	No
10:45:00 PM	78	52	No
11:00:00 PM	77	52	No
11:15:00 PM	76	52	No
11:30:00 PM	80	52	No
11:45:00 PM	81	52	No

RD11 Weekends Elevated Receivers			
Time	Leq15 Threshold	Predicted	Exceedance (Yes/No)
12:00:00 AM	75	52	No
12:15:00 AM	74	52	No
12:30:00 AM	76	52	No
12:45:00 AM	74	52	No
1:00:00 AM	73	52	No
1:15:00 AM	73	52	No
1:30:00 AM	74	52	No
1:45:00 AM	72	52	No
2:00:00 AM	73	52	No
2:15:00 AM	76	52	No
2:30:00 AM	73	52	No
2:45:00 AM	73	52	No
3:00:00 AM	76	52	No
3:15:00 AM	73	52	No
3:30:00 AM	75	52	No
3:45:00 AM	70	52	No
4:00:00 AM	74	52	No
4:15:00 AM	70	52	No
4:30:00 AM	72	52	No
4:45:00 AM	74	52	No
5:00:00 AM	69	52	No
5:15:00 AM	68	52	No
5:30:00 AM	71	52	No
5:45:00 AM	69	52	No
6:00:00 AM	71	52	No
6:15:00 AM	72	52	No
6:30:00 AM	73	52	No
6:45:00 AM	72	52	No
7:00:00 AM	74	52	No
7:15:00 AM	74	52	No
7:30:00 AM	74	52	No
7:45:00 AM	74	52	No
8:00:00 AM	75	52	No
8:15:00 AM	81	52	No
8:30:00 AM	75	52	No
8:45:00 AM	75	52	No
9:00:00 AM	76	52	No
9:15:00 AM	75	52	No
9:30:00 AM	76	52	No
9:45:00 AM	77	52	No
10:00:00 AM	75	52	No
10:15:00 AM	76	52	No
10:30:00 AM	76	52	No
10:45:00 AM	79	52	No
11:00:00 AM	76	52	No
11:15:00 AM	76	52	No
11:30:00 AM	76	52	No
11:45:00 AM	84	52	No
12:00:00 PM	76	52	No
12:15:00 PM	77	52	No
12:30:00 PM	78	52	No
12:45:00 PM	78	52	No
1:00:00 PM	77	52	No
1:15:00 PM	77	52	No
1:30:00 PM	77	52	No
1:45:00 PM	77	52	No
2:00:00 PM	76	52	No

RD11 Weekends Elevated Receivers			
Time	Leq15 Threshold	Predicted	Exceedance (Yes/No)
2:15:00 PM	77	52	No
2:30:00 PM	77	52	No
2:45:00 PM	76	52	No
3:00:00 PM	77	52	No
3:15:00 PM	76	52	No
3:30:00 PM	76	52	No
3:45:00 PM	76	52	No
4:00:00 PM	80	52	No
4:15:00 PM	76	52	No
4:30:00 PM	76	52	No
4:45:00 PM	80	52	No
5:00:00 PM	77	52	No
5:15:00 PM	76	52	No
5:30:00 PM	76	52	No
5:45:00 PM	80	52	No
6:00:00 PM	76	52	No
6:15:00 PM	77	52	No
6:30:00 PM	77	52	No
6:45:00 PM	75	52	No
7:00:00 PM	78	52	No
7:15:00 PM	77	52	No
7:30:00 PM	78	52	No
7:45:00 PM	78	52	No
8:00:00 PM	78	52	No
8:15:00 PM	78	52	No
8:30:00 PM	77	52	No
8:45:00 PM	77	52	No
9:00:00 PM	80	52	No
9:15:00 PM	77	52	No
9:30:00 PM	76	52	No
9:45:00 PM	78	52	No
10:00:00 PM	76	52	No
10:15:00 PM	78	52	No
10:30:00 PM	77	52	No
10:45:00 PM	76	52	No
11:00:00 PM	75	52	No
11:15:00 PM	74	52	No
11:30:00 PM	78	52	No
11:45:00 PM	79	52	No

RD12 Weekdays			
Time	Leq15 Threshold	Predicted	Exceedance (Yes/No)
12:00:00 AM	70	43	No
12:15:00 AM	68	43	No
12:30:00 AM	68	43	No
12:45:00 AM	69	43	No
1:00:00 AM	72	43	No
1:15:00 AM	64	43	No
1:30:00 AM	69	43	No
1:45:00 AM	67	43	No
2:00:00 AM	64	43	No
2:15:00 AM	65	43	No
2:30:00 AM	73	43	No
2:45:00 AM	70	43	No
3:00:00 AM	77	43	No
3:15:00 AM	70	43	No
3:30:00 AM	63	43	No
3:45:00 AM	67	43	No
4:00:00 AM	64	43	No
4:15:00 AM	62	43	No
4:30:00 AM	65	43	No
4:45:00 AM	72	43	No
5:00:00 AM	67	43	No
5:15:00 AM	66	43	No
5:30:00 AM	71	43	No
5:45:00 AM	72	43	No
6:00:00 AM	70	43	No
6:15:00 AM	74	43	No
6:30:00 AM	73	43	No
6:45:00 AM	72	43	No
7:00:00 AM	73	43	No
7:15:00 AM	74	43	No
7:30:00 AM	73	43	No
7:45:00 AM	74	43	No
8:00:00 AM	75	43	No
8:15:00 AM	75	43	No
8:30:00 AM	76	43	No
8:45:00 AM	75	43	No
9:00:00 AM	76	43	No
9:15:00 AM	76	43	No
9:30:00 AM	75	43	No
9:45:00 AM	77	43	No
10:00:00 AM	77	43	No
10:15:00 AM	76	43	No
10:30:00 AM	76	43	No
10:45:00 AM	75	43	No
11:00:00 AM	76	43	No
11:15:00 AM	74	43	No
11:30:00 AM	75	43	No
11:45:00 AM	76	43	No
12:00:00 PM	76	43	No
12:15:00 PM	82	43	No
12:30:00 PM	75	43	No
12:45:00 PM	76	43	No
1:00:00 PM	75	43	No
1:15:00 PM	76	43	No
1:30:00 PM	75	43	No
1:45:00 PM	75	43	No
2:00:00 PM	75	43	No

<b>RD12 Weekdays</b>			
<b>Time</b>	<b>Leq15 Threshold</b>	<b>Predicted</b>	<b>Exceedance (Yes/No)</b>
2:15:00 PM	75	43	No
2:30:00 PM	75	43	No
2:45:00 PM	74	43	No
3:00:00 PM	75	43	No
3:15:00 PM	75	43	No
3:30:00 PM	74	43	No
3:45:00 PM	75	43	No
4:00:00 PM	76	43	No
4:15:00 PM	74	43	No
4:30:00 PM	75	43	No
4:45:00 PM	79	43	No
5:00:00 PM	76	43	No
5:15:00 PM	74	43	No
5:30:00 PM	76	43	No
5:45:00 PM	75	43	No
6:00:00 PM	75	43	No
6:15:00 PM	74	43	No
6:30:00 PM	74	43	No
6:45:00 PM	76	43	No
7:00:00 PM	74	43	No
7:15:00 PM	73	43	No
7:30:00 PM	72	43	No
7:45:00 PM	72	43	No
8:00:00 PM	71	43	No
8:15:00 PM	72	43	No
8:30:00 PM	72	43	No
8:45:00 PM	71	43	No
9:00:00 PM	72	43	No
9:15:00 PM	72	43	No
9:30:00 PM	74	43	No
9:45:00 PM	71	43	No
10:00:00 PM	74	43	No
10:15:00 PM	73	43	No
10:30:00 PM	72	43	No
10:45:00 PM	69	43	No
11:00:00 PM	71	43	No
11:15:00 PM	71	43	No
11:30:00 PM	69	43	No
11:45:00 PM	69	43	No



RD12 Elevated Receiver			
Time	Leq15 Threshold	Predicted	Exceedance (Yes/No)
12:00:00 AM	67	43	No
12:15:00 AM	66	43	No
12:30:00 AM	65	43	No
12:45:00 AM	67	43	No
1:00:00 AM	69	43	No
1:15:00 AM	61	43	No
1:30:00 AM	67	43	No
1:45:00 AM	64	43	No
2:00:00 AM	62	43	No
2:15:00 AM	62	43	No
2:30:00 AM	70	43	No
2:45:00 AM	68	43	No
3:00:00 AM	74	43	No
3:15:00 AM	68	43	No
3:30:00 AM	61	43	No
3:45:00 AM	65	43	No
4:00:00 AM	61	43	No
4:15:00 AM	59	43	No
4:30:00 AM	63	43	No
4:45:00 AM	70	43	No
5:00:00 AM	65	43	No
5:15:00 AM	64	43	No
5:30:00 AM	68	43	No
5:45:00 AM	69	43	No
6:00:00 AM	68	43	No
6:15:00 AM	72	43	No
6:30:00 AM	70	43	No
6:45:00 AM	70	43	No
7:00:00 AM	71	43	No
7:15:00 AM	72	43	No
7:30:00 AM	71	43	No
7:45:00 AM	72	43	No
8:00:00 AM	72	43	No
8:15:00 AM	73	43	No
8:30:00 AM	74	43	No
8:45:00 AM	73	43	No
9:00:00 AM	73	43	No
9:15:00 AM	73	43	No
9:30:00 AM	72	43	No
9:45:00 AM	74	43	No
10:00:00 AM	74	43	No
10:15:00 AM	73	43	No
10:30:00 AM	73	43	No
10:45:00 AM	73	43	No
11:00:00 AM	73	43	No
11:15:00 AM	72	43	No
11:30:00 AM	72	43	No
11:45:00 AM	73	43	No
12:00:00 PM	73	43	No
12:15:00 PM	79	43	No
12:30:00 PM	73	43	No
12:45:00 PM	74	43	No
1:00:00 PM	73	43	No
1:15:00 PM	74	43	No
1:30:00 PM	73	43	No
1:45:00 PM	72	43	No
2:00:00 PM	73	43	No

RD12 Elevated Receiver			
Time	Leq15 Threshold	Predicted	Exceedance (Yes/No)
2:15:00 PM	72	43	No
2:30:00 PM	73	43	No
2:45:00 PM	72	43	No
3:00:00 PM	73	43	No
3:15:00 PM	72	43	No
3:30:00 PM	72	43	No
3:45:00 PM	73	43	No
4:00:00 PM	74	43	No
4:15:00 PM	72	43	No
4:30:00 PM	73	43	No
4:45:00 PM	76	43	No
5:00:00 PM	74	43	No
5:15:00 PM	72	43	No
5:30:00 PM	73	43	No
5:45:00 PM	73	43	No
6:00:00 PM	72	43	No
6:15:00 PM	72	43	No
6:30:00 PM	72	43	No
6:45:00 PM	73	43	No
7:00:00 PM	71	43	No
7:15:00 PM	70	43	No
7:30:00 PM	69	43	No
7:45:00 PM	70	43	No
8:00:00 PM	69	43	No
8:15:00 PM	69	43	No
8:30:00 PM	69	43	No
8:45:00 PM	68	43	No
9:00:00 PM	69	43	No
9:15:00 PM	70	43	No
9:30:00 PM	71	43	No
9:45:00 PM	68	43	No
10:00:00 PM	72	43	No
10:15:00 PM	70	43	No
10:30:00 PM	70	43	No
10:45:00 PM	67	43	No
11:00:00 PM	69	43	No
11:15:00 PM	68	43	No
11:30:00 PM	66	43	No
11:45:00 PM	67	43	No

RD13 Weekdays			
Time	Leq15 Threshold	Predicted	Exceedance (Yes/No)
12:00:00 AM	76	50	No
12:15:00 AM	75	50	No
12:30:00 AM	74	50	No
12:45:00 AM	88	50	No
1:00:00 AM	73	50	No
1:15:00 AM	72	50	No
1:30:00 AM	87	50	No
1:45:00 AM	82	50	No
2:00:00 AM	77	50	No
2:15:00 AM	74	50	No
2:30:00 AM	74	50	No
2:45:00 AM	71	50	No
3:00:00 AM	72	50	No
3:15:00 AM	72	50	No
3:30:00 AM	71	50	No
3:45:00 AM	71	50	No
4:00:00 AM	72	50	No
4:15:00 AM	70	50	No
4:30:00 AM	73	50	No
4:45:00 AM	75	50	No
5:00:00 AM	75	50	No
5:15:00 AM	75	50	No
5:30:00 AM	77	50	No
5:45:00 AM	77	50	No
6:00:00 AM	78	50	No
6:15:00 AM	79	50	No
6:30:00 AM	84	50	No
6:45:00 AM	86	50	No
7:00:00 AM	84	50	No
7:15:00 AM	84	50	No
7:30:00 AM	84	50	No
7:45:00 AM	82	50	No
8:00:00 AM	84	50	No
8:15:00 AM	80	50	No
8:30:00 AM	81	50	No
8:45:00 AM	81	50	No
9:00:00 AM	80	50	No
9:15:00 AM	80	50	No
9:30:00 AM	80	50	No
9:45:00 AM	79	50	No
10:00:00 AM	83	50	No
10:15:00 AM	79	50	No
10:30:00 AM	79	50	No
10:45:00 AM	79	50	No
11:00:00 AM	79	50	No
11:15:00 AM	79	50	No
11:30:00 AM	79	50	No
11:45:00 AM	79	50	No
12:00:00 PM	79	50	No
12:15:00 PM	79	50	No
12:30:00 PM	78	50	No
12:45:00 PM	78	50	No
1:00:00 PM	80	50	No
1:15:00 PM	80	50	No
1:30:00 PM	79	50	No
1:45:00 PM	79	50	No
2:00:00 PM	81	50	No

RD13 Weekdays			
Time	Leq15 Threshold	Predicted	Exceedance (Yes/No)
2:15:00 PM	78	50	No
2:30:00 PM	78	50	No
2:45:00 PM	79	50	No
3:00:00 PM	78	50	No
3:15:00 PM	79	50	No
3:30:00 PM	79	50	No
3:45:00 PM	78	50	No
4:00:00 PM	79	50	No
4:15:00 PM	85	50	No
4:30:00 PM	78	50	No
4:45:00 PM	80	50	No
5:00:00 PM	79	50	No
5:15:00 PM	78	50	No
5:30:00 PM	77	50	No
5:45:00 PM	77	50	No
6:00:00 PM	78	50	No
6:15:00 PM	78	50	No
6:30:00 PM	77	50	No
6:45:00 PM	78	50	No
7:00:00 PM	78	50	No
7:15:00 PM	78	50	No
7:30:00 PM	78	50	No
7:45:00 PM	80	50	No
8:00:00 PM	78	50	No
8:15:00 PM	78	50	No
8:30:00 PM	78	50	No
8:45:00 PM	78	50	No
9:00:00 PM	78	50	No
9:15:00 PM	78	50	No
9:30:00 PM	78	50	No
9:45:00 PM	77	50	No
10:00:00 PM	85	50	No
10:15:00 PM	79	50	No
10:30:00 PM	78	50	No
10:45:00 PM	76	50	No
11:00:00 PM	77	50	No
11:15:00 PM	77	50	No
11:30:00 PM	75	50	No
11:45:00 PM	76	50	No

RD13 Elevated Receiver			
Time	Leq15 Threshold	Predicted	Exceedance (Yes/No)
12:00:00 AM	75	50	No
12:15:00 AM	74	50	No
12:30:00 AM	73	50	No
12:45:00 AM	87	50	No
1:00:00 AM	72	50	No
1:15:00 AM	71	50	No
1:30:00 AM	86	50	No
1:45:00 AM	81	50	No
2:00:00 AM	76	50	No
2:15:00 AM	73	50	No
2:30:00 AM	73	50	No
2:45:00 AM	70	50	No
3:00:00 AM	71	50	No
3:15:00 AM	71	50	No
3:30:00 AM	70	50	No
3:45:00 AM	70	50	No
4:00:00 AM	71	50	No
4:15:00 AM	70	50	No
4:30:00 AM	72	50	No
4:45:00 AM	74	50	No
5:00:00 AM	74	50	No
5:15:00 AM	74	50	No
5:30:00 AM	76	50	No
5:45:00 AM	76	50	No
6:00:00 AM	77	50	No
6:15:00 AM	78	50	No
6:30:00 AM	83	50	No
6:45:00 AM	85	50	No
7:00:00 AM	83	50	No
7:15:00 AM	83	50	No
7:30:00 AM	83	50	No
7:45:00 AM	81	50	No
8:00:00 AM	84	50	No
8:15:00 AM	80	50	No
8:30:00 AM	80	50	No
8:45:00 AM	80	50	No
9:00:00 AM	79	50	No
9:15:00 AM	79	50	No
9:30:00 AM	79	50	No
9:45:00 AM	78	50	No
10:00:00 AM	82	50	No
10:15:00 AM	78	50	No
10:30:00 AM	78	50	No
10:45:00 AM	78	50	No
11:00:00 AM	78	50	No
11:15:00 AM	78	50	No
11:30:00 AM	78	50	No
11:45:00 AM	78	50	No
12:00:00 PM	78	50	No
12:15:00 PM	78	50	No
12:30:00 PM	77	50	No
12:45:00 PM	78	50	No
1:00:00 PM	79	50	No
1:15:00 PM	79	50	No
1:30:00 PM	78	50	No
1:45:00 PM	78	50	No
2:00:00 PM	80	50	No

<b>RD13 Elevated Receiver</b>			
<b>Time</b>	<b>Leq15 Threshold</b>	<b>Predicted</b>	<b>Exceedance (Yes/No)</b>
2:15:00 PM	77	50	No
2:30:00 PM	77	50	No
2:45:00 PM	78	50	No
3:00:00 PM	77	50	No
3:15:00 PM	78	50	No
3:30:00 PM	78	50	No
3:45:00 PM	77	50	No
4:00:00 PM	78	50	No
4:15:00 PM	84	50	No
4:30:00 PM	77	50	No
4:45:00 PM	79	50	No
5:00:00 PM	78	50	No
5:15:00 PM	77	50	No
5:30:00 PM	77	50	No
5:45:00 PM	76	50	No
6:00:00 PM	77	50	No
6:15:00 PM	77	50	No
6:30:00 PM	76	50	No
6:45:00 PM	77	50	No
7:00:00 PM	77	50	No
7:15:00 PM	77	50	No
7:30:00 PM	77	50	No
7:45:00 PM	79	50	No
8:00:00 PM	77	50	No
8:15:00 PM	77	50	No
8:30:00 PM	77	50	No
8:45:00 PM	77	50	No
9:00:00 PM	77	50	No
9:15:00 PM	78	50	No
9:30:00 PM	77	50	No
9:45:00 PM	76	50	No
10:00:00 PM	85	50	No
10:15:00 PM	78	50	No
10:30:00 PM	77	50	No
10:45:00 PM	75	50	No
11:00:00 PM	76	50	No
11:15:00 PM	76	50	No
11:30:00 PM	75	50	No
11:45:00 PM	75	50	No

RD13 Elevated Receiver -Weekends			
Time	Leq15 Threshold	Predicted	Exceedance (Yes/No)
12:00:00 AM	76	50	No
12:15:00 AM	75	50	No
12:30:00 AM	77	50	No
12:45:00 AM	75	50	No
1:00:00 AM	75	50	No
1:15:00 AM	75	50	No
1:30:00 AM	76	50	No
1:45:00 AM	75	50	No
2:00:00 AM	72	50	No
2:15:00 AM	81	50	No
2:30:00 AM	71	50	No
2:45:00 AM	70	50	No
3:00:00 AM	73	50	No
3:15:00 AM	73	50	No
3:30:00 AM	74	50	No
3:45:00 AM	72	50	No
4:00:00 AM	73	50	No
4:15:00 AM	73	50	No
4:30:00 AM	73	50	No
4:45:00 AM	75	50	No
5:00:00 AM	74	50	No
5:15:00 AM	75	50	No
5:30:00 AM	74	50	No
5:45:00 AM	75	50	No
6:00:00 AM	75	50	No
6:15:00 AM	75	50	No
6:30:00 AM	76	50	No
6:45:00 AM	77	50	No
7:00:00 AM	76	50	No
7:15:00 AM	77	50	No
7:30:00 AM	74	50	No
7:45:00 AM	75	50	No
8:00:00 AM	75	50	No
8:15:00 AM	75	50	No
8:30:00 AM	76	50	No
8:45:00 AM	76	50	No
9:00:00 AM	76	50	No
9:15:00 AM	75	50	No
9:30:00 AM	77	50	No
9:45:00 AM	76	50	No
10:00:00 AM	77	50	No
10:15:00 AM	76	50	No
10:30:00 AM	76	50	No
10:45:00 AM	76	50	No
11:00:00 AM	76	50	No
11:15:00 AM	79	50	No
11:30:00 AM	78	50	No
11:45:00 AM	78	50	No
12:00:00 PM	78	50	No
12:15:00 PM	75	50	No
12:30:00 PM	77	50	No
12:45:00 PM	76	50	No
1:00:00 PM	77	50	No
1:15:00 PM	85	50	No
1:30:00 PM	87	50	No
1:45:00 PM	81	50	No
2:00:00 PM	78	50	No

<b>RD13 Elevated Receiver - Weekends</b>			
<b>Time</b>	<b>Leq15 Threshold</b>	<b>Predicted</b>	<b>Exceedance (Yes/No)</b>
2:15:00 PM	77	50	No
2:30:00 PM	78	50	No
2:45:00 PM	77	50	No
3:00:00 PM	76	50	No
3:15:00 PM	76	50	No
3:30:00 PM	78	50	No
3:45:00 PM	77	50	No
4:00:00 PM	76	50	No
4:15:00 PM	76	50	No
4:30:00 PM	76	50	No
4:45:00 PM	76	50	No
5:00:00 PM	81	50	No
5:15:00 PM	78	50	No
5:30:00 PM	76	50	No
5:45:00 PM	75	50	No
6:00:00 PM	76	50	No
6:15:00 PM	76	50	No
6:30:00 PM	76	50	No
6:45:00 PM	76	50	No
7:00:00 PM	77	50	No
7:15:00 PM	78	50	No
7:30:00 PM	77	50	No
7:45:00 PM	83	50	No
8:00:00 PM	80	50	No
8:15:00 PM	78	50	No
8:30:00 PM	78	50	No
8:45:00 PM	79	50	No
9:00:00 PM	78	50	No
9:15:00 PM	79	50	No
9:30:00 PM	77	50	No
9:45:00 PM	77	50	No
10:00:00 PM	77	50	No
10:15:00 PM	81	50	No
10:30:00 PM	76	50	No
10:45:00 PM	77	50	No
11:00:00 PM	77	50	No
11:15:00 PM	78	50	No
11:30:00 PM	82	50	No
11:45:00 PM	76	50	No



RD14 Elevated Receiver			
Time	Leq15 Threshold	Predicted	Exceedance (Yes/No)
12:00:00 AM	70	57	No
12:15:00 AM	70	57	No
12:30:00 AM	67	57	No
12:45:00 AM	79	57	No
1:00:00 AM	67	57	No
1:15:00 AM	65	57	No
1:30:00 AM	77	57	No
1:45:00 AM	74	57	No
2:00:00 AM	64	57	No
2:15:00 AM	65	57	No
2:30:00 AM	66	57	No
2:45:00 AM	66	57	No
3:00:00 AM	70	57	No
3:15:00 AM	67	57	No
3:30:00 AM	64	57	No
3:45:00 AM	64	57	No
4:00:00 AM	65	57	No
4:15:00 AM	65	57	No
4:30:00 AM	68	57	No
4:45:00 AM	69	57	No
5:00:00 AM	69	57	No
5:15:00 AM	72	57	No
5:30:00 AM	71	57	No
5:45:00 AM	72	57	No
6:00:00 AM	72	57	No
6:15:00 AM	72	57	No
6:30:00 AM	74	57	No
6:45:00 AM	75	57	No
7:00:00 AM	73	57	No
7:15:00 AM	74	57	No
7:30:00 AM	76	57	No
7:45:00 AM	75	57	No
8:00:00 AM	75	57	No
8:15:00 AM	74	57	No
8:30:00 AM	75	57	No
8:45:00 AM	76	57	No
9:00:00 AM	75	57	No
9:15:00 AM	76	57	No
9:30:00 AM	75	57	No
9:45:00 AM	74	57	No
10:00:00 AM	78	57	No
10:15:00 AM	74	57	No
10:30:00 AM	73	57	No
10:45:00 AM	75	57	No
11:00:00 AM	73	57	No
11:15:00 AM	73	57	No
11:30:00 AM	73	57	No
11:45:00 AM	74	57	No
12:00:00 PM	76	57	No
12:15:00 PM	74	57	No
12:30:00 PM	73	57	No
12:45:00 PM	72	57	No
1:00:00 PM	74	57	No
1:15:00 PM	74	57	No
1:30:00 PM	73	57	No
1:45:00 PM	73	57	No
2:00:00 PM	74	57	No
2:15:00 PM	73	57	No
2:30:00 PM	74	57	No

RD14 Elevated Receiver			
Time	Leq15 Threshold	Predicted	Exceedance (Yes/No)
2 45:00 PM	76	57	No
3 00:00 PM	74	57	No
3 15:00 PM	73	57	No
3 30:00 PM	74	57	No
3 45:00 PM	74	57	No
4 00:00 PM	74	57	No
4 15:00 PM	73	57	No
4 30:00 PM	73	57	No
4 45:00 PM	73	57	No
5 00:00 PM	73	57	No
5 15:00 PM	74	57	No
5 30:00 PM	73	57	No
5 45:00 PM	73	57	No
6 00:00 PM	74	57	No
6 15:00 PM	71	57	No
6 30:00 PM	71	57	No
6 45:00 PM	71	57	No
7 00:00 PM	73	57	No
7 15:00 PM	73	57	No
7 30:00 PM	72	57	No
7 45:00 PM	72	57	No
8 00 00 PM	72	57	No
8 15:00 PM	72	57	No
8 30:00 PM	72	57	No
8 45 00 PM	71	57	No
9 00 00 PM	71	57	No
9 15 00 PM	72	57	No
9 30 00 PM	73	57	No
9 45 00 PM	70	57	No
10 00:00 PM	79	57	No
10 15 00 PM	71	57	No
10 30 00 PM	76	57	No
10 45 00 PM	70	57	No
11 00 00 PM	70	57	No
11 15 00 PM	70	57	No
11 30 00 PM	69	57	No
11 45 00 PM	69	57	No

RD14 Elevated Receiver - Weekend			
Time	Leq15 Threshold	Predicted	Exceedance (Yes/No)
12:00:00 AM	68	57	No
12:15:00 AM	69	57	No
12:30:00 AM	68	57	No
12:45:00 AM	66	57	No
1:00:00 AM	66	57	No
1:15:00 AM	66	57	No
1:30:00 AM	66	57	No
1:45:00 AM	65	57	No
2:00:00 AM	64	57	No
2:15:00 AM	68	57	No
2:30:00 AM	64	57	No
2:45:00 AM	66	57	No
3:00:00 AM	67	57	No
3:15:00 AM	66	57	No
3:30:00 AM	66	57	No
3:45:00 AM	63	57	No
4:00:00 AM	62	57	No
4:15:00 AM	62	57	No
4:30:00 AM	63	57	No
4:45:00 AM	65	57	No
5:00:00 AM	61	57	No
5:15:00 AM	60	57	No
5:30:00 AM	64	57	No
5:45:00 AM	64	57	No
6:00:00 AM	62	57	No
6:15:00 AM	65	57	No
6:30:00 AM	66	57	No
6:45:00 AM	66	57	No
7:00:00 AM	68	57	No
7:15:00 AM	67	57	No
7:30:00 AM	68	57	No
7:45:00 AM	68	57	No
8:00:00 AM	68	57	No
8:15:00 AM	69	57	No
8:30:00 AM	68	57	No
8:45:00 AM	69	57	No
9:00:00 AM	70	57	No
9:15:00 AM	69	57	No
9:30:00 AM	69	57	No
9:45:00 AM	71	57	No
10:00:00 AM	69	57	No
10:15:00 AM	70	57	No
10:30:00 AM	69	57	No
10:45:00 AM	70	57	No
11:00:00 AM	69	57	No
11:15:00 AM	69	57	No
11:30:00 AM	70	57	No
11:45:00 AM	74	57	No
12:00:00 PM	70	57	No
12:15:00 PM	70	57	No
12:30:00 PM	71	57	No
12:45:00 PM	71	57	No
1:00:00 PM	71	57	No
1:15:00 PM	70	57	No
1:30:00 PM	69	57	No
1:45:00 PM	70	57	No
2:00:00 PM	70	57	No
2:15:00 PM	71	57	No
2:30:00 PM	70	57	No

<b>RD14 Elevated Receiver - Weekend</b>			
<b>Time</b>	<b>Leq15 Threshold</b>	<b>Predicted</b>	<b>Exceedance (Yes/No)</b>
2:45:00 PM	71	57	No
3:00:00 PM	72	57	No
3:15:00 PM	69	57	No
3:30:00 PM	69	57	No
3:45:00 PM	69	57	No
4:00:00 PM	74	57	No
4:15:00 PM	69	57	No
4:30:00 PM	70	57	No
4:45:00 PM	73	57	No
5:00:00 PM	70	57	No
5:15:00 PM	69	57	No
5:30:00 PM	70	57	No
5:45:00 PM	71	57	No
6:00:00 PM	69	57	No
6:15:00 PM	70	57	No
6:30:00 PM	69	57	No
6:45:00 PM	70	57	No
7:00:00 PM	71	57	No
7:15:00 PM	72	57	No
7:30:00 PM	71	57	No
7:45:00 PM	71	57	No
8:00:00 PM	71	57	No
8:15:00 PM	71	57	No
8:30:00 PM	71	57	No
8:45:00 PM	71	57	No
9:00:00 PM	71	57	No
9:15:00 PM	70	57	No
9:30:00 PM	70	57	No
9:45:00 PM	71	57	No
10:00:00 PM	69	57	No
10:15:00 PM	70	57	No
10:30:00 PM	70	57	No
10:45:00 PM	69	57	No
11:00:00 PM	69	57	No
11:15:00 PM	70	57	No
11:30:00 PM	69	57	No
11:45:00 PM	72	57	No

RD15 Weekdays			
Time	Leq15 Threshold	Predicted	Exceedance (Yes/No)
12:00:00 AM	63	58	No
12:15:00 AM	63	58	No
12:30:00 AM	63	58	No
12:45:00 AM	76	58	No
1:00:00 AM	75	58	No
1:15:00 AM	61	58	No
1:30:00 AM	74	58	No
1:45:00 AM	69	58	No
2:00:00 AM	61	58	No
2:15:00 AM	61	58	No
2:30:00 AM	64	58	No
2:45:00 AM	64	58	No
3:00:00 AM	64	58	No
3:15:00 AM	62	58	No
3:30:00 AM	64	58	No
3:45:00 AM	61	58	No
4:00:00 AM	61	58	No
4:15:00 AM	62	58	No
4:30:00 AM	63	58	No
4:45:00 AM	64	58	No
5:00:00 AM	69	58	No
5:15:00 AM	63	58	No
5:30:00 AM	65	58	No
5:45:00 AM	64	58	No
6:00:00 AM	68	58	No
6:15:00 AM	71	58	No
6:30:00 AM	78	58	No
6:45:00 AM	75	58	No
7:00:00 AM	71	58	No
7:15:00 AM	76	58	No
7:30:00 AM	71	58	No
7:45:00 AM	72	58	No
8:00:00 AM	72	58	No
8:15:00 AM	74	58	No
8:30:00 AM	75	58	No
8:45:00 AM	74	58	No
9:00:00 AM	74	58	No
9:15:00 AM	76	58	No
9:30:00 AM	76	58	No
9:45:00 AM	76	58	No
10:00:00 AM	75	58	No
10:15:00 AM	72	58	No
10:30:00 AM	70	58	No
10:45:00 AM	73	58	No
11:00:00 AM	72	58	No
11:15:00 AM	76	58	No
11:30:00 AM	71	58	No
11:45:00 AM	74	58	No
12:00:00 PM	73	58	No
12:15:00 PM	68	58	No
12:30:00 PM	71	58	No
12:45:00 PM	75	58	No
1:00:00 PM	78	58	No
1:15:00 PM	78	58	No
1:30:00 PM	75	58	No
1:45:00 PM	73	58	No

RD15 Weekdays			
Time	Leq15 Threshold	Predicted	Exceedance (Yes/No)
2:00:00 PM	76	58	No
2:15:00 PM	74	58	No
2:30:00 PM	76	58	No
2:45:00 PM	75	58	No
3:00:00 PM	75	58	No
3:15:00 PM	75	58	No
3:30:00 PM	74	58	No
3:45:00 PM	74	58	No
4:00:00 PM	73	58	No
4:15:00 PM	82	58	No
4:30:00 PM	74	58	No
4:45:00 PM	77	58	No
5:00:00 PM	69	58	No
5:15:00 PM	68	58	No
5:30:00 PM	67	58	No
5:45:00 PM	68	58	No
6:00:00 PM	70	58	No
6:15:00 PM	66	58	No
6:30:00 PM	66	58	No
6:45:00 PM	72	58	No
7:00:00 PM	68	58	No
7:15:00 PM	67	58	No
7:30:00 PM	66	58	No
7:45:00 PM	67	58	No
8:00:00 PM	66	58	No
8:15:00 PM	65	58	No
8:30:00 PM	66	58	No
8:45:00 PM	68	58	No
9:00:00 PM	68	58	No
9:15:00 PM	71	58	No
9:30:00 PM	67	58	No
9:45:00 PM	74	58	No
10:00:00 PM	82	58	No
10:15:00 PM	78	58	No
10:30:00 PM	72	58	No
10:45:00 PM	67	58	No
11:00:00 PM	65	58	No
11:15:00 PM	65	58	No
11:30:00 PM	68	58	No
11:45:00 PM	66	58	No

RD15 Elevated Receivers			
Time	Leq15 Threshold	Predicted	Exceedance (Yes/No)
12:00:00 AM	65	59	No
12:15:00 AM	65	59	No
12:30:00 AM	64	59	No
12:45:00 AM	78	59	No
1:00:00 AM	77	59	No
1:15:00 AM	63	59	No
1:30:00 AM	75	59	No
1:45:00 AM	71	59	No
2:00:00 AM	63	59	No
2:15:00 AM	63	59	No
2:30:00 AM	66	59	No
2:45:00 AM	65	59	No
3:00:00 AM	65	59	No
3:15:00 AM	63	59	No
3:30:00 AM	66	59	No
3:45:00 AM	63	59	No
4:00:00 AM	63	59	No
4:15:00 AM	63	59	No
4:30:00 AM	64	59	No
4:45:00 AM	66	59	No
5:00:00 AM	71	59	No
5:15:00 AM	65	59	No
5:30:00 AM	67	59	No
5:45:00 AM	66	59	No
6:00:00 AM	70	59	No
6:15:00 AM	72	59	No
6:30:00 AM	80	59	No
6:45:00 AM	76	59	No
7:00:00 AM	72	59	No
7:15:00 AM	77	59	No
7:30:00 AM	72	59	No
7:45:00 AM	74	59	No
8:00:00 AM	74	59	No
8:15:00 AM	75	59	No
8:30:00 AM	77	59	No
8:45:00 AM	76	59	No
9:00:00 AM	75	59	No
9:15:00 AM	77	59	No
9:30:00 AM	77	59	No
9:45:00 AM	78	59	No
10:00:00 AM	76	59	No
10:15:00 AM	74	59	No
10:30:00 AM	71	59	No
10:45:00 AM	74	59	No
11:00:00 AM	74	59	No
11:15:00 AM	78	59	No
11:30:00 AM	73	59	No
11:45:00 AM	76	59	No
12:00:00 PM	74	59	No
12:15:00 PM	70	59	No
12:30:00 PM	72	59	No
12:45:00 PM	77	59	No
1:00:00 PM	80	59	No
1:15:00 PM	80	59	No
1:30:00 PM	77	59	No
1:45:00 PM	75	59	No
2:00:00 PM	77	59	No

RD15 Elevated Receivers			
Time	Leq15 Threshold	Predicted	Exceedance (Yes/No)
2:15:00 PM	75	59	No
2:30:00 PM	77	59	No
2:45:00 PM	77	59	No
3:00:00 PM	76	59	No
3:15:00 PM	76	59	No
3:30:00 PM	76	59	No
3:45:00 PM	76	59	No
4:00:00 PM	75	59	No
4:15:00 PM	84	59	No
4:30:00 PM	75	59	No
4:45:00 PM	78	59	No
5:00:00 PM	70	59	No
5:15:00 PM	70	59	No
5:30:00 PM	69	59	No
5:45:00 PM	70	59	No
6:00:00 PM	71	59	No
6:15:00 PM	68	59	No
6:30:00 PM	67	59	No
6:45:00 PM	74	59	No
7:00:00 PM	69	59	No
7:15:00 PM	68	59	No
7:30:00 PM	67	59	No
7:45:00 PM	68	59	No
8:00:00 PM	68	59	No
8:15:00 PM	67	59	No
8:30:00 PM	68	59	No
8:45:00 PM	69	59	No
9:00:00 PM	70	59	No
9:15:00 PM	72	59	No
9:30:00 PM	69	59	No
9:45:00 PM	76	59	No
10:00:00 PM	83	59	No
10:15:00 PM	79	59	No
10:30:00 PM	74	59	No
10:45:00 PM	68	59	No
11:00:00 PM	67	59	No
11:15:00 PM	67	59	No
11:30:00 PM	69	59	No
11:45:00 PM	67	59	No



RD15 Elevated Receivers -Weekend			
Time	Leq15 Threshold	Predicted	Exceedance (Yes/No)
12:00:00 AM	71	59	No
12:15:00 AM	70	59	No
12:30:00 AM	70	59	No
12:45:00 AM	71	59	No
1:00:00 AM	70	59	No
1:15:00 AM	71	59	No
1:30:00 AM	70	59	No
1:45:00 AM	70	59	No
2:00:00 AM	68	59	No
2:15:00 AM	70	59	No
2:30:00 AM	68	59	No
2:45:00 AM	68	59	No
3:00:00 AM	69	59	No
3:15:00 AM	70	59	No
3:30:00 AM	70	59	No
3:45:00 AM	70	59	No
4:00:00 AM	70	59	No
4:15:00 AM	70	59	No
4:30:00 AM	79	59	No
4:45:00 AM	89	59	No
5:00:00 AM	77	59	No
5:15:00 AM	71	59	No
5:30:00 AM	69	59	No
5:45:00 AM	69	59	No
6:00:00 AM	70	59	No
6:15:00 AM	70	59	No
6:30:00 AM	70	59	No
6:45:00 AM	74	59	No
7:00:00 AM	75	59	No
7:15:00 AM	74	59	No
7:30:00 AM	72	59	No
7:45:00 AM	69	59	No
8:00:00 AM	70	59	No
8:15:00 AM	69	59	No
8:30:00 AM	70	59	No
8:45:00 AM	69	59	No
9:00:00 AM	69	59	No
9:15:00 AM	69	59	No
9:30:00 AM	70	59	No
9:45:00 AM	70	59	No
10:00:00 AM	69	59	No
10:15:00 AM	69	59	No
10:30:00 AM	70	59	No
10:45:00 AM	70	59	No
11:00:00 AM	70	59	No
11:15:00 AM	71	59	No
11:30:00 AM	72	59	No
11:45:00 AM	66	59	No
12:00:00 PM	68	59	No
12:15:00 PM	65	59	No
12:30:00 PM	64	59	No
12:45:00 PM	64	59	No
1:00:00 PM	68	59	No
1:15:00 PM	69	59	No
1:30:00 PM	76	59	No
1:45:00 PM	67	59	No
2:00:00 PM	65	59	No
2:15:00 PM	65	59	No

RD15 Elevated Receivers -Weekend		59	
Time	Leq15 Threshold	59	Exceedance (Yes/No)
2:30:00 PM	65	59	No
2:45:00 PM	74	59	No
3:00:00 PM	65	59	No
3:15:00 PM	66	59	No
3:30:00 PM	69	59	No
3:45:00 PM	68	59	No
4:00:00 PM	69	59	No
4:15:00 PM	70	59	No
4:30:00 PM	70	59	No
4:45:00 PM	70	59	No
5:00:00 PM	74	59	No
5:15:00 PM	69	59	No
5:30:00 PM	70	59	No
5:45:00 PM	70	59	No
6:00:00 PM	69	59	No
6:15:00 PM	69	59	No
6:30:00 PM	69	59	No
6:45:00 PM	70	59	No
7:00:00 PM	71	59	No
7:15:00 PM	71	59	No
7:30:00 PM	73	59	No
7:45:00 PM	76	59	No
8:00:00 PM	72	59	No
8:15:00 PM	78	59	No
8:30:00 PM	71	59	No
8:45:00 PM	71	59	No
9:00:00 PM	71	59	No
9:15:00 PM	72	59	No
9:30:00 PM	71	59	No
9:45:00 PM	71	59	No
10:00:00 PM	71	59	No
10:15:00 PM	71	59	No
10:30:00 PM	71	59	No
10:45:00 PM	72	59	No
11:00:00 PM	71	59	No
11:15:00 PM	72	59	No
11:30:00 PM	74	59	No
11:45:00 PM	71	59	No

RD16 Weekdays			
Time	Leq15 Threshold	Predicted	Exceedance (Yes/No)
12:00:00 AM	71	57	No
12:15:00 AM	72	57	No
12:30:00 AM	68	57	No
12:45:00 AM	70	57	No
1:00:00 AM	69	57	No
1:15:00 AM	65	57	No
1:30:00 AM	66	57	No
1:45:00 AM	66	57	No
2:00:00 AM	72	57	No
2:15:00 AM	69	57	No
2:30:00 AM	71	57	No
2:45:00 AM	62	57	No
3:00:00 AM	70	57	No
3:15:00 AM	63	57	No
3:30:00 AM	62	57	No
3:45:00 AM	70	57	No
4:00:00 AM	64	57	No
4:15:00 AM	67	57	No
4:30:00 AM	67	57	No
4:45:00 AM	68	57	No
5:00:00 AM	71	57	No
5:15:00 AM	72	57	No
5:30:00 AM	73	57	No
5:45:00 AM	71	57	No
6:00:00 AM	74	57	No
6:15:00 AM	76	57	No
6:30:00 AM	78	57	No
6:45:00 AM	75	57	No
7:00:00 AM	76	57	No
7:15:00 AM	81	57	No
7:30:00 AM	76	57	No
7:45:00 AM	76	57	No
8:00:00 AM	77	57	No
8:15:00 AM	75	57	No
8:30:00 AM	74	57	No
8:45:00 AM	80	57	No
9:00:00 AM	76	57	No
9:15:00 AM	79	57	No
9:30:00 AM	76	57	No
9:45:00 AM	75	57	No
10:00:00 AM	77	57	No
10:15:00 AM	75	57	No
10:30:00 AM	75	57	No
10:45:00 AM	75	57	No
11:00:00 AM	76	57	No
11:15:00 AM	76	57	No
11:30:00 AM	75	57	No
11:45:00 AM	76	57	No
12:00:00 PM	76	57	No
12:15:00 PM	76	57	No
12:30:00 PM	76	57	No
12:45:00 PM	77	57	No
1:00:00 PM	76	57	No
1:15:00 PM	76	57	No
1:30:00 PM	74	57	No
1:45:00 PM	77	57	No
2:00:00 PM	74	57	No
2:15:00 PM	75	57	No

RD16 Weekdays			
Time	Leq15 Threshold	Predicted	Exceedance (Yes/No)
2:30:00 PM	74	57	No
2:45:00 PM	75	57	No
3:00:00 PM	78	57	No
3:15:00 PM	75	57	No
3:30:00 PM	75	57	No
3:45:00 PM	75	57	No
4:00:00 PM	77	57	No
4:15:00 PM	76	57	No
4:30:00 PM	74	57	No
4:45:00 PM	76	57	No
5:00:00 PM	74	57	No
5:15:00 PM	76	57	No
5:30:00 PM	76	57	No
5:45:00 PM	76	57	No
6:00:00 PM	77	57	No
6:15:00 PM	75	57	No
6:30:00 PM	83	57	No
6:45:00 PM	78	57	No
7:00:00 PM	75	57	No
7:15:00 PM	74	57	No
7:30:00 PM	76	57	No
7:45:00 PM	77	57	No
8:00:00 PM	84	57	No
8:15:00 PM	75	57	No
8:30:00 PM	76	57	No
8:45:00 PM	76	57	No
9:00:00 PM	75	57	No
9:15:00 PM	75	57	No
9:30:00 PM	75	57	No
9:45:00 PM	80	57	No
10:00:00 PM	74	57	No
10:15:00 PM	75	57	No
10:30:00 PM	76	57	No
10:45:00 PM	74	57	No
11:00:00 PM	71	57	No
11:15:00 PM	73	57	No
11:30:00 PM	70	57	No
11:45:00 PM	76	57	No

RD16 Weekends			
Time	Leq15 Threshold	Predicted	Exceedance (Yes/No)
12:00:00 AM	70	57	No
12:15:00 AM	73	57	No
12:30:00 AM	73	57	No
12:45:00 AM	71	57	No
1:00:00 AM	68	57	No
1:15:00 AM	69	57	No
1:30:00 AM	77	57	No
1:45:00 AM	67	57	No
2:00:00 AM	74	57	No
2:15:00 AM	80	57	No
2:30:00 AM	72	57	No
2:45:00 AM	72	57	No
3:00:00 AM	77	57	No
3:15:00 AM	77	57	No
3:30:00 AM	73	57	No
3:45:00 AM	68	57	No
4:00:00 AM	75	57	No
4:15:00 AM	71	57	No
4:30:00 AM	72	57	No
4:45:00 AM	72	57	No
5:00:00 AM	62	57	No
5:15:00 AM	64	57	No
5:30:00 AM	66	57	No
5:45:00 AM	68	57	No
6:00:00 AM	64	57	No
6:15:00 AM	74	57	No
6:30:00 AM	68	57	No
6:45:00 AM	69	57	No
7:00:00 AM	68	57	No
7:15:00 AM	69	57	No
7:30:00 AM	70	57	No
7:45:00 AM	69	57	No
8:00:00 AM	73	57	No
8:15:00 AM	69	57	No
8:30:00 AM	72	57	No
8:45:00 AM	71	57	No
9:00:00 AM	71	57	No
9:15:00 AM	71	57	No
9:30:00 AM	72	57	No
9:45:00 AM	73	57	No
10:00:00 AM	73	57	No
10:15:00 AM	75	57	No
10:30:00 AM	74	57	No
10:45:00 AM	75	57	No
11:00:00 AM	71	57	No
11:15:00 AM	71	57	No
11:30:00 AM	72	57	No
11:45:00 AM	74	57	No
12:00:00 PM	74	57	No
12:15:00 PM	72	57	No
12:30:00 PM	73	57	No
12:45:00 PM	75	57	No
1:00:00 PM	74	57	No
1:15:00 PM	74	57	No
1:30:00 PM	74	57	No
1:45:00 PM	74	57	No
2:00:00 PM	75	57	No

RD16 Weekends			
Time	Leq15 Threshold	Predicted	Exceedance (Yes/No)
2:15:00 PM	74	57	No
2:30:00 PM	73	57	No
2:45:00 PM	72	57	No
3:00:00 PM	74	57	No
3:15:00 PM	73	57	No
3:30:00 PM	72	57	No
3:45:00 PM	72	57	No
4:00:00 PM	75	57	No
4:15:00 PM	75	57	No
4:30:00 PM	73	57	No
4:45:00 PM	74	57	No
5:00:00 PM	73	57	No
5:15:00 PM	74	57	No
5:30:00 PM	73	57	No
5:45:00 PM	73	57	No
6:00:00 PM	71	57	No
6:15:00 PM	73	57	No
6:30:00 PM	72	57	No
6:45:00 PM	75	57	No
7:00:00 PM	74	57	No
7:15:00 PM	74	57	No
7:30:00 PM	75	57	No
7:45:00 PM	74	57	No
8:00:00 PM	74	57	No
8:15:00 PM	75	57	No
8:30:00 PM	75	57	No
8:45:00 PM	76	57	No
9:00:00 PM	75	57	No
9:15:00 PM	76	57	No
9:30:00 PM	75	57	No
9:45:00 PM	75	57	No
10:00:00 PM	77	57	No
10:15:00 PM	76	57	No
10:30:00 PM	73	57	No
10:45:00 PM	75	57	No
11:00:00 PM	73	57	No
11:15:00 PM	75	57	No
11:30:00 PM	72	57	No
11:45:00 PM	73	57	No

# **Attachment 2**

## Cut and Cover Option

Item No.	Description	Item Bid Estimate
<b>METRO BEVERLY HILLS NORTH PORTAL - CUT &amp; COVER OPTION</b>		<b>\$ 52,602,000</b>
1	EXCAVATION AND SUPPORT	\$ 25,975,000
2	STATION - PERMANENT STRUCTURE	\$ 22,716,000
3	TUNNEL - PERMANENT STRUCTURE	\$ 3,384,000
5	SITE RESTORATION	\$ 527,000
<b>CIVIL WORKS</b>		<b>\$ 5,500,000</b>
6	UTILITY RELOCATIONS	\$ 3,000,000
7	TRAFFIC DIVERSIONS	\$ 2,500,000
<b>TEMPORARY WORKS</b>		<b>\$ 2,250,000</b>
8	GEOTECHNICAL INSTRUMENTATION AND MONITORING	\$ 250,000
9	DEWATERING	\$ 2,000,000
<b>MEP</b>		<b>\$ 2,200,000</b>
10	PLUMBING, FIRE PROTECTION, ELECTRICAL, VENTILATION, AND ELEVATOR EQUIPMENT ROOM	\$ 2,200,000
<b>ARCHITECTURAL FINISHES</b>		<b>\$ 4,250,000</b>
11	ESCALATORS	\$ 1,300,000
12	ELEVATORS	\$ 900,000
13	FARE GATES	\$ 400,000
14	SIGNAGE	\$ 150,000
15	ARCHITECTURAL FINISH WORK	\$ 1,500,000
16	PUBLIC ARTWORK	\$ -
<b>PLAZA CONSTRUCTION</b>		<b>\$ 1,800,000</b>
17	PLAZA AND STREET RESTORATION	\$ 700,000
18	CANOPY	\$ 1,100,000
<b>BASE BID ESTIMATE</b>		<b>\$ 68,602,000</b>
19	MOBILIZATION/DEMobilIZATION @5%	\$ 3,431,000
20	BOND & INSURANCE @1%	\$ 721,000
21	CONTINGENCY @40%	\$ 29,102,000
<b>UNOFFICIAL TOTAL BID ESTIMATE (2023 \$)</b>		<b>\$ 101,856,000</b>
22	ESCALATION (4% YEARLY, UNTIL 2025)	\$ 8,312,000
<b>UNOFFICIAL TOTAL BID ESTIMATE (2025 \$)</b>		<b>\$ 110,168,000</b>
<b>OTHER PROJECT RELATED ESTIMATED COSTS</b>		<b>\$ 24,061,440</b>
23	FINAL DESIGN	\$ 9,000,000
24	DESIGN SUPPORT DURING CONSTRUCTION	\$ 5,000,000
25	CONSTRUCTION MANAGEMENT (8% OF CONSTRUCTION COSTS)	\$ 8,813,440
26	CLIENT COSTS (3 FTEs FOR 4 YEARS @ \$200/HR)	\$ 1,248,000
<b>TOTAL PROJECT RELATED ESTIMATED COSTS</b>		<b>\$ 134,229,440</b>



# **Attachment 3**

## North Portal Project – Expended Cost Summary

The costs below are rounded to the nearest thousand.

### City of Beverly Hills

Description	Approximate Costs
City Staff	\$ 142,000
Environmental Impact Report (EIR) services	\$ 919,000
Design services	\$ 1,390,000
Other (economic analysis, outreach, etc.)	\$ 180,000
Total	\$ 2,631,000

### LA Metro

Description	Approximate Costs
Metro Staff	\$ 53,000
Consultant Support for Interface Only	\$ 196,000
Change Final Design of Interface	\$ 1,000,000
Change for Construction of Interface	\$ 6,490,000
Total	\$ 7,739,000

Total approximate expenditures to date: \$10,370,000.